

386489

BBL NO.	ITEM DESCRIPTION	WEIGHT	MATL CODE	QTY REQD	ITEM NO.	MODEL NAME
1	ANGLE-.10X1.50X1.50X 13.25	0.334	BB2	4	385287	P15C0410
2	CHANNEL-LADDER SUPPORT	0.175	BB1	1	386485	P16C0532
3	CHANNEL-LADDER SUPPORT	0.317	BB1	3	386448	P16C0395
4	NUT-HEX .25 SST	0.007	E1	42	807862	807862
5	NUT-HEX .38 LK	0.018	E1	10	1485	1485
6	NUT-UNISTRUT W/O SPRING .38-16	0.086	C4	56	802807	802807
7	PIPE STOP SHEET	1.127	BB2	1	386422	P16C0285
8	SCREW-CARRIAGE .25X .50	0.013	E0	27	826255	826255
9	SCREW-CARRIAGE .25X .75	0.018	E0	9	1430	1430
10	SCREW-HEX 3/8-13X 1.00 FLANGE	0.059	E1	10	1490	1490
11	SCREW-HEX.25X1.50 SST	0.027	E0	6	803172	803172
12	SCREW-HEX.38X .75 GR5	0.043	E0	56	802804	802804
13	SHEET-.12X 4.00X 19.50	9.610	BB1	1	386447	P16C0394
14	SHELF-LADDER LH 55"	12.274	BB2	1	386459	P16C0459
15	SHELF-LADDER RH	10.508	BB2	1	386490	P16C0557
16	SHELF-TOP 18"x73.833"	16.710	BB2	1	386442	P16C0456
17	SHELF-TRAY 18"x23"	4.981	BB2	6	386376	SHELF_1_DS
18	SHELF-TRAY 18"x46"	9.633	BB2	6	385297	SHELF_2_DS
19	SUPPORT ASM-LADDER	0.447	ZA	3	385200	385200
20	UNISTRUT ASM-DOUBLE	9.025	ZA	1	386445	386445
21	UNISTRUT ASM-END	6.531	ZA	1	386484	386484
22	UNISTRUT ASM-SINGLE	5.998	ZA	2	386446	386446
23	WASHER-FENDER .25 SST	0.009	E2	12	820746	820746
24	WASHER-FLAT .38 D-SHAPED	0.007	E2	56	816154	816154
25	WASHER-LOCK .25 SST	0.002	E2	42	803630	803630

NOTE:
1.) FOR OPTIONAL SHELF LINER KIT, USE PART NUMBER #386494.

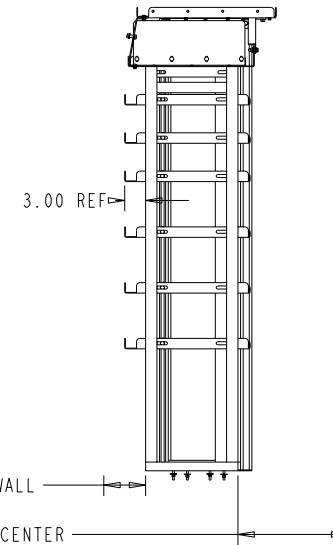

VIEW FROM REAR OF VAN

SCALE 0.080

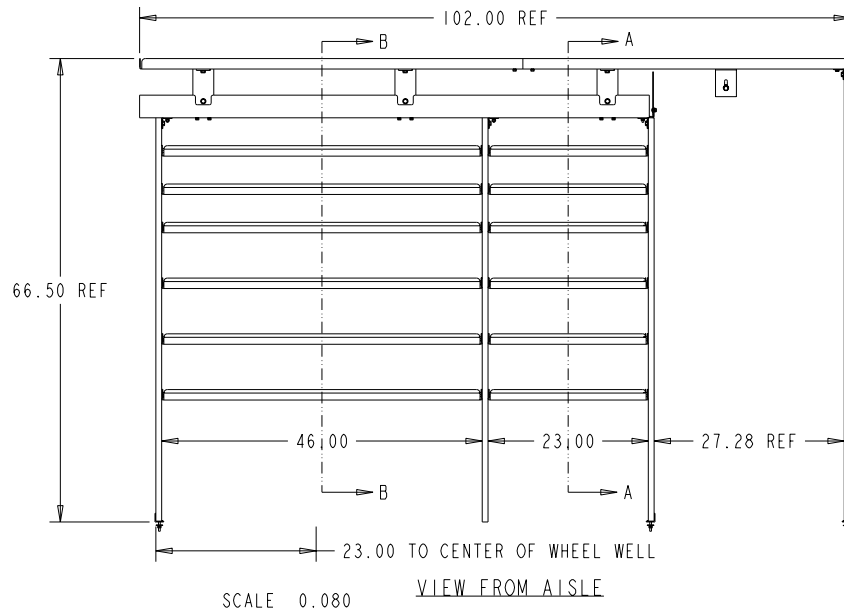

VIEW FROM AISLE

SCALE 0.080

THIS PRINT AND ALL RIGHTS TO THE DESIGN AND DETAIL THEREON ARE THE PROPERTY OF VT HACKNEY AND IS LOANED TO THE RECIPIENT SUBJECT TO RETURN UPON DEMAND. ITS CONTENTS ARE CONFIDENTIAL AND MUST NOT BE COPIED OR SUBMITTED TO OUTSIDE PARTIES FOR USE OR EXAMINATION. COPYRIGHT 2015 VT HACKNEY A COMPANY OF VT SYSTEMS

REV	REVISION DESCRIPTION	ECN	DATE	INITIALS

CNUMBER	WEIGHT	TOLERANCE UNLESS OTHERWISE SPECIFIED	
SPRINTER	180.017		
ROUTING	MATL CODE		
FINAL	ZA	.XX=+/- .060 .XXX=+/- .030	
ITEM NO	SHAPE DESC		
386489			
RAW/MATL	HRS		
	0.000		
DRAWN BY	DATE	DESCRIPTION	
ALB	12-Oct-16	vthackney.com hackney.com kidron.com vtvisioncomms.com	
APPROVED BY	DATE		
SUPERSEDES	SUPERSEDED BY	SCALE	DWG NAME
		0.033	



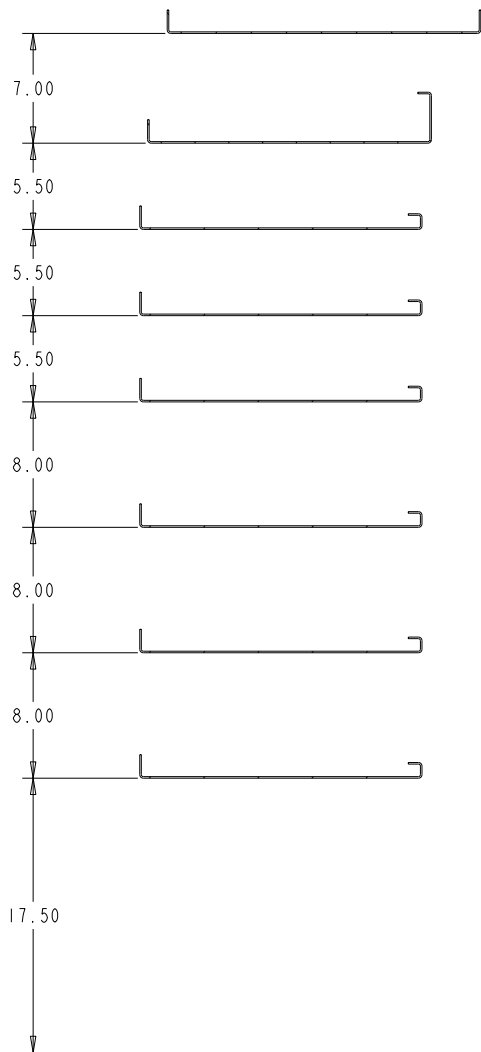

252-946-6521
SHELF ASM- DRIVERSIDE SPRINTER 144"WB HIGH ROOF 23-46

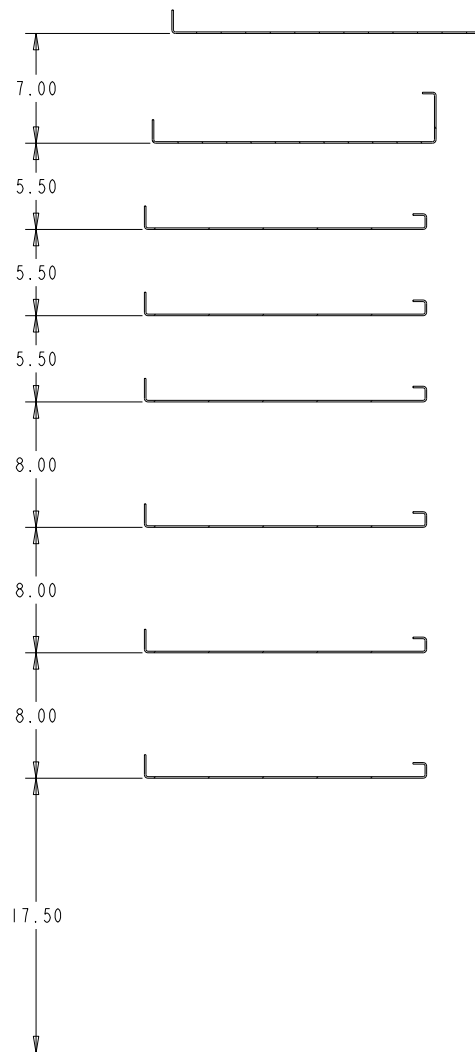

SECTION A-A
SCALE 0.180



SECTION B-B
SCALE 0.180

CNUMBER SPRINTER	WEIGHT 180.017	TOLERANCE UNLESS OTHERWISE SPECIFIED	 VT Hackney A company of VT Systems	
ROUTING FINAL	MATL CODE ZA	.XX=+/- .060 XXX=+/- .030		
ITEM NO 386489	SHAPE DESC		252-946-6521 vtackney.com hackney.com kidron.com vtvisioncomms.com VisionComms	
RAW MATL	HRS 0.000	DESCRIPTION		
DRAWN BY ALB	DATE 12-Oct-16	SHELF ASM- DRIVERSIDE SPRINTER 144"WB HIGH ROOF 23-46		
APPROVED BY	DATE	SCALE 0.033	DWG NAME P16C0556 Sheet 2 of 4	
SUPERSEDES	SUPERSEDED BY			

BUILDUP DETAIL

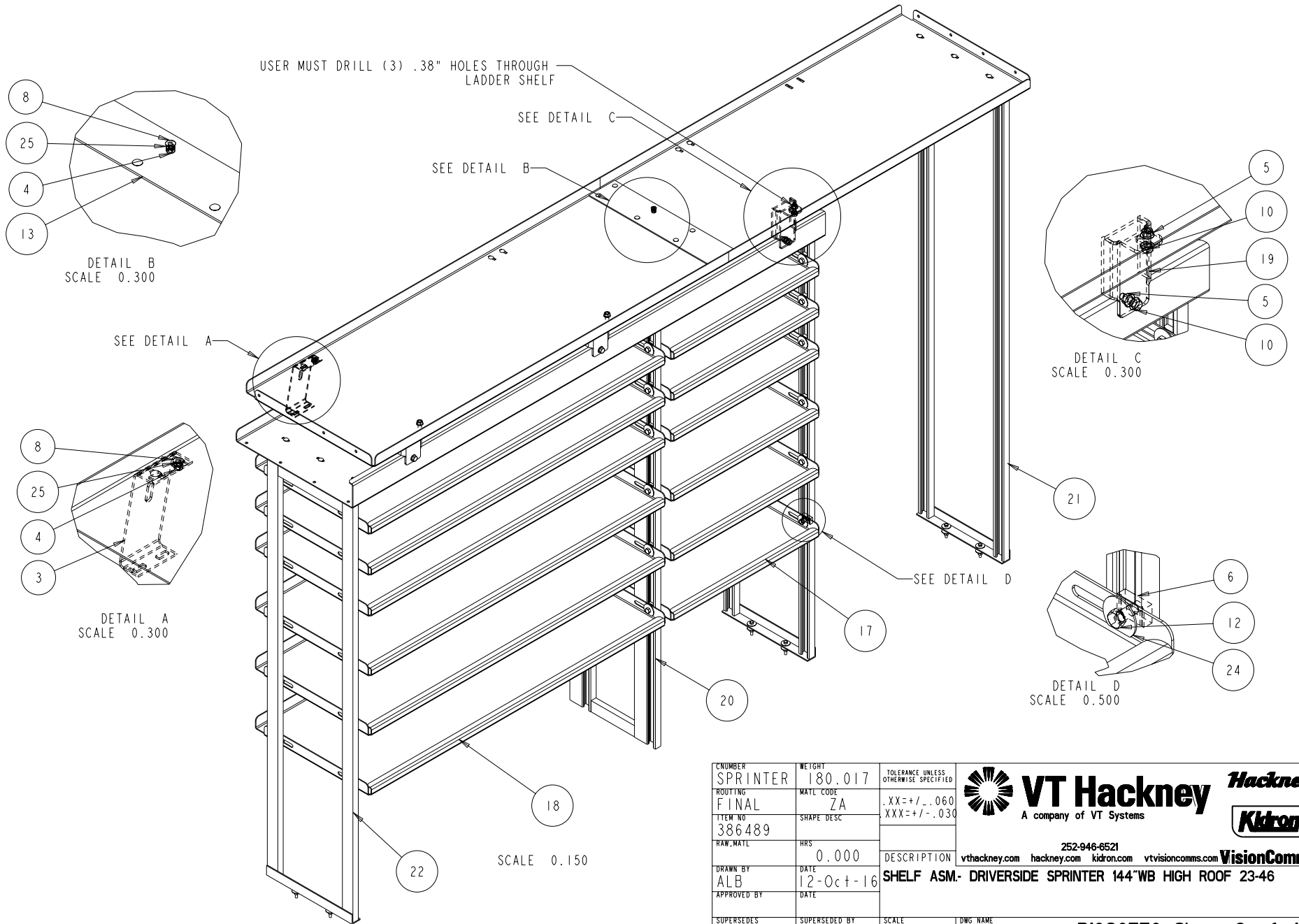

CNUMBER	WEIGHT	TOLERANCE UNLESS OTHERWISE SPECIFIED
SPRINTER	180.017	
ROUTING	MATL CODE	
FINAL	ZA	.XX=+/- .060 XXX=+/- .030
ITEM NO	SHAPE DESC	
386489		
RAW/MATL	HRS	
	0.000	
DRAWN BY	DATE	DESCRIPTION
ALB	12-Oct-16	vtackney.com hackney.com kidron.com vtvisioncomms.com
APPROVED BY	DATE	SHELF ASM- DRIVERSIDE SPRINTER 144"WB HIGH ROOF 23-46
SUPERSEDES	SUPERSEDED BY	SCALE
		0.033
		DWG NAME



VT Hackney
A company of VT Systems

Hackney



VisionComms

ATTACHMENT DETAILS

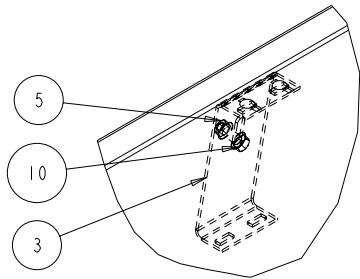

DETAIL E
SCALE 0.300

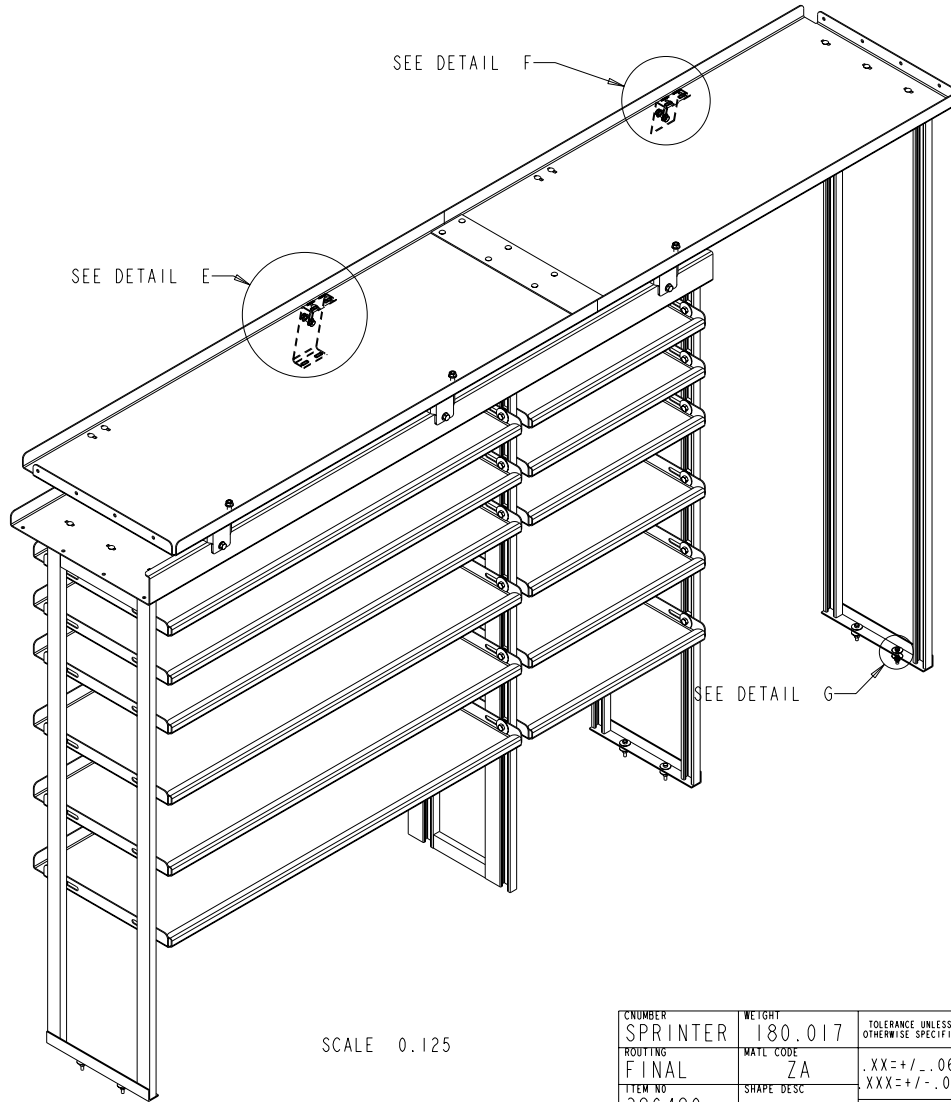

SCALE 0.125

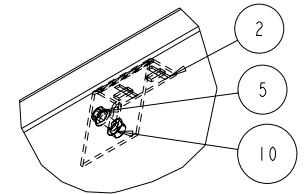

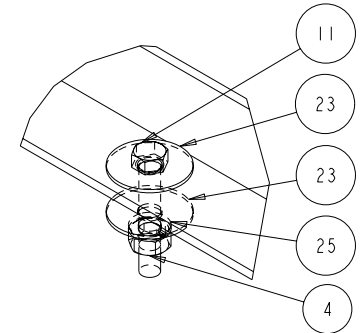

DETAIL F
SCALE 0.300



DETAIL G
SCALE 1.000

INSTALLATION NOTES:
 1.) INSTALLER RESPONSIBLE FOR SECURING SHELVING UNIT TO THE VAN USING SUPPLIED HARDWARE NOTED IN DETAILS E, F, AND G.
 2.) BEFORE DRILLING ANY HOLE THROUGH FLOOR OR WALL, VERIFY CLEARANCE ON BACKSIDE OF HOLE.

CNUMBER SPRINTER	WEIGHT 180.017	TOLERANCE UNLESS OTHERWISE SPECIFIED	 VT Hackney A company of VT Systems	
ROUTING FINAL	MATL CODE ZA	.XX=+/- .060 XXX=+/- .030		
ITEM NO 386489	SHAPE DESC		252-946-6521 vtackney.com hackney.com kidron.com vtvisioncomms.com	
RAW_MATL	HRS 0.000	DESCRIPTION SHELF ASM- DRIVERSIDE SPRINTER 144"WB HIGH ROOF 23-46		
DRAWN BY ALB	DATE 12-Oct-16			
APPROVED BY	DATE			
SUPERSEDES	SUPERSEDED BY	SCALE 0.033	DWG NAME	P16C0556 Sheet 4 of 4