

386482

BBL NO.	ITEM DESCRIPTION	WEIGHT	MATL CODE	QTY REQD	ITEM NO.	MODEL NAME
1	ANGLE-.10X1.50X1.50X 13.25	0.334	BB2	4	385287	P15C0410
2	CHANNEL-LADDER SUPPORT	0.317	BB1	4	386448	P16C0395
3	NUT-HEX .25 SST	0.007	E1	48	807862	807862
4	NUT-HEX .38 LK	0.018	E1	13	1485	1485
5	NUT-UNISTRUT W/O SPRING .38-16	0.086	C4	84	802807	802807
6	PIPE STOP SHEET	1.127	BB2	1	386422	P16C0285
7	SCREW-CARRIAGE .25X .50	0.013	E0	42	826255	826255
8	SCREW-HEX 3/8-13X 1.00 FLANGE	0.059	E1	13	1490	1490
9	SCREW-HEX.25X1.50 SST	0.027	E0	6	803172	803172
10	SCREW-HEX.38X .75 GR5	0.043	E0	84	802804	802804
11	SHEET-.12X 4.00X 19.50	9.610	BB1	1	386447	P16C0394
12	SHELF-LADDER LH	17.981	BB2	1	386449	P16C0396
13	SHELF-LADDER RH	15.344	BB2	1	386486	P16C0531
14	SHELF-TOP 18"x47.00"	10.834	BB2	1	386415	P16C0298
15	SHELF-TOP 18"x73"	16.489	BB2	1	386416	P16C0183
16	SHELF-TRAY 18"x23"	4.981	BB2	6	386376	SHELF_3_DS
17	SHELF-TRAY 18"x46"	9.633	BB2	6	385297	SHELF_1_DS
18	SHELF-TRAY 18"x46"	9.633	BB2	6	385297	SHELF_2_DS
19	SUPPORT - LADDER SUPPORT	0.175	BB1	1	386485	P16C0532
20	SUPPORT ASM-LADDER	0.447	ZA	4	385200	385200
21	UNISTRUT ASM-DOUBLE	9.025	ZA	2	386445	386445
22	UNISTRUT ASM-SINGLE	5.998	ZA	2	386446	386446
23	UNISTRUT ASM-SINGLE	6.531	ZA	1	386484	386484
24	WASHER-FENDER .25 SST	0.009	E2	12	820746	820746
25	WASHER-FLAT .38 D-SHAPED	0.007	E2	84	816154	816154
26	WASHER-LOCK .25 SST	0.002	E2	48	803630	803630

NOTE:  
1.) FOR OPTIONAL SHELF LINER KIT, USE PART NUMBER #386493

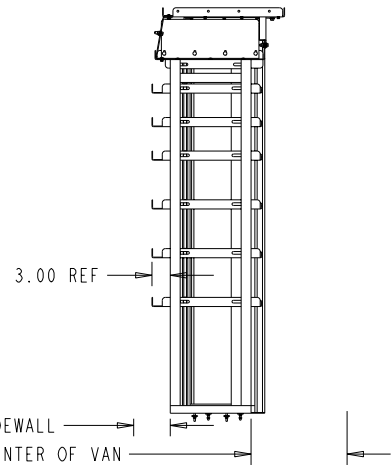

VIEW FROM REAR OF VAN

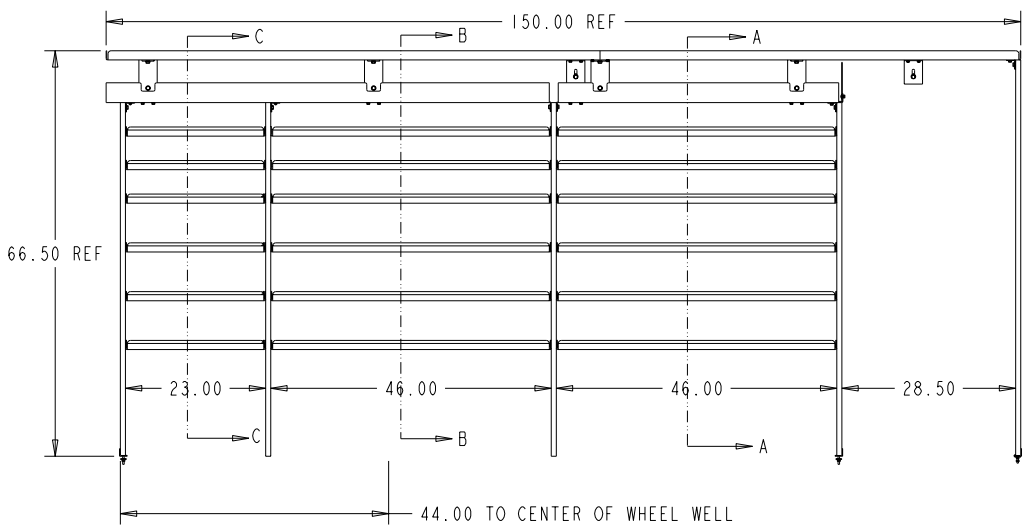

VIEW FROM AISLE

SCALE 0.070

THIS PRINT AND ALL RIGHTS TO THE DESIGN AND DETAIL THEREON ARE THE PROPERTY OF VT HACKNEY AND IS LOANED TO THE RECIPIENT SUBJECT TO RETURN UPON DEMAND. ITS CONTENTS ARE CONFIDENTIAL AND MUST NOT BE COPIED OR SUBMITTED TO OUTSIDE PARTIES FOR USE OR EXAMINATION. COPYRIGHT 2015 VT HACKNEY A COMPANY OF VT SYSTEMS

REV	REVISION DESCRIPTION	ECN	DATE	INITIALS

CNUMBER	WEIGHT	TOLERANCE UNLESS OTHERWISE SPECIFIED
SPRINTER	273.479	
ROUTING	MATL CODE	
FINAL	ZA	.XX=+/- .060 .XXX=+/- .030
ITEM NO	SHAPE DESC	
386482		
RAW/MATL	HRS	
	0.000	
DRAWN BY	DATE	
ALB	05-Oct-16	
APPROVED BY	DATE	
SUPERSEDES	SUPERSEDED BY	SCALE
		0.029

**VT Hackney** *Hackney*  
A company of VT Systems **Kidron**

252-946-6521  
vthackney.com hackney.com kidron.com vtvisioncomms.com **VisionComms**  
DESCRIPTION **SHELF ASM- DRIVERSIDE SPRINTER 170" WB HIGH ROOF 46-46-23**

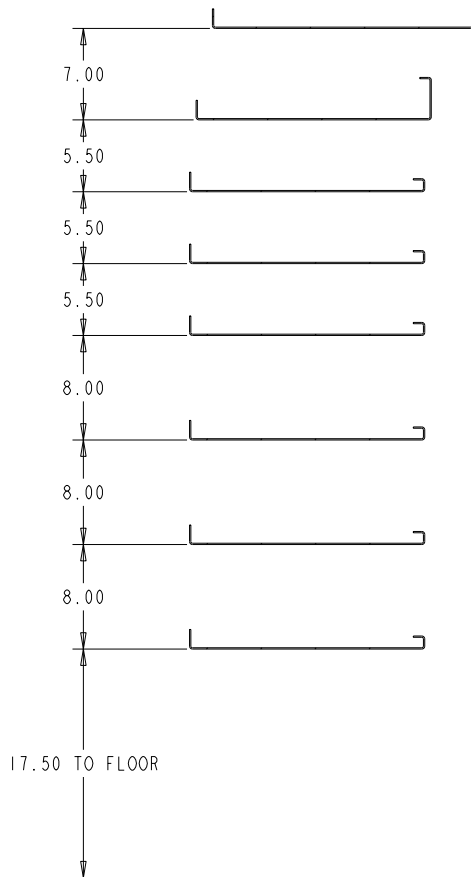

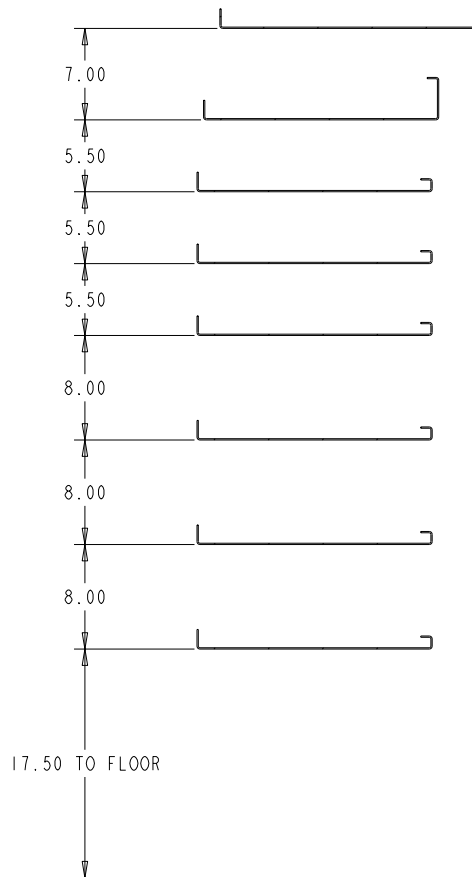

SECTION A-A  
SCALE 0.150

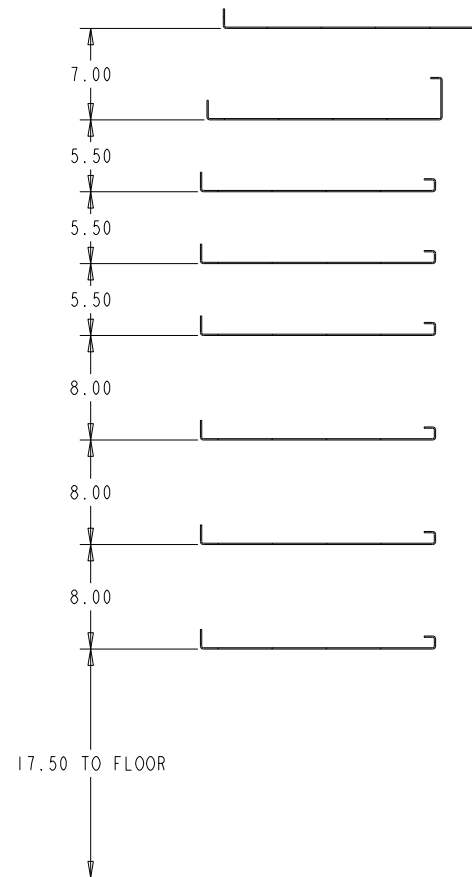

SECTION B-B  
SCALE 0.150





SECTION C-C  
SCALE 0.150

CNUMBER SPRINTER	WEIGHT 273.479	TOLERANCE UNLESS OTHERWISE SPECIFIED	 <b>VT Hackney</b> A company of VT Systems	
ROUTING FINAL	MATL CODE ZA	.XX=+/- .060 .XXX=+/- .030		
ITEM NO 386482	SHAPE DESC			
RAW_MATL	HRS 0.000	DESCRIPTION	252-946-6521 vthackney.com hackney.com kidron.com vtvisioncomms.com <b>VisionComms</b>	
DRAWN BY ALB	DATE 05-0ct-16	SHELF ASM- DRIVERSIDE SPRINTER 170" WB HIGH ROOF 46-46-23		
APPROVED BY	DATE			
SUPERSEDES	SUPERSEDED BY	SCALE 0.029	DWG NAME P16C0530 Sheet 2 of 4	

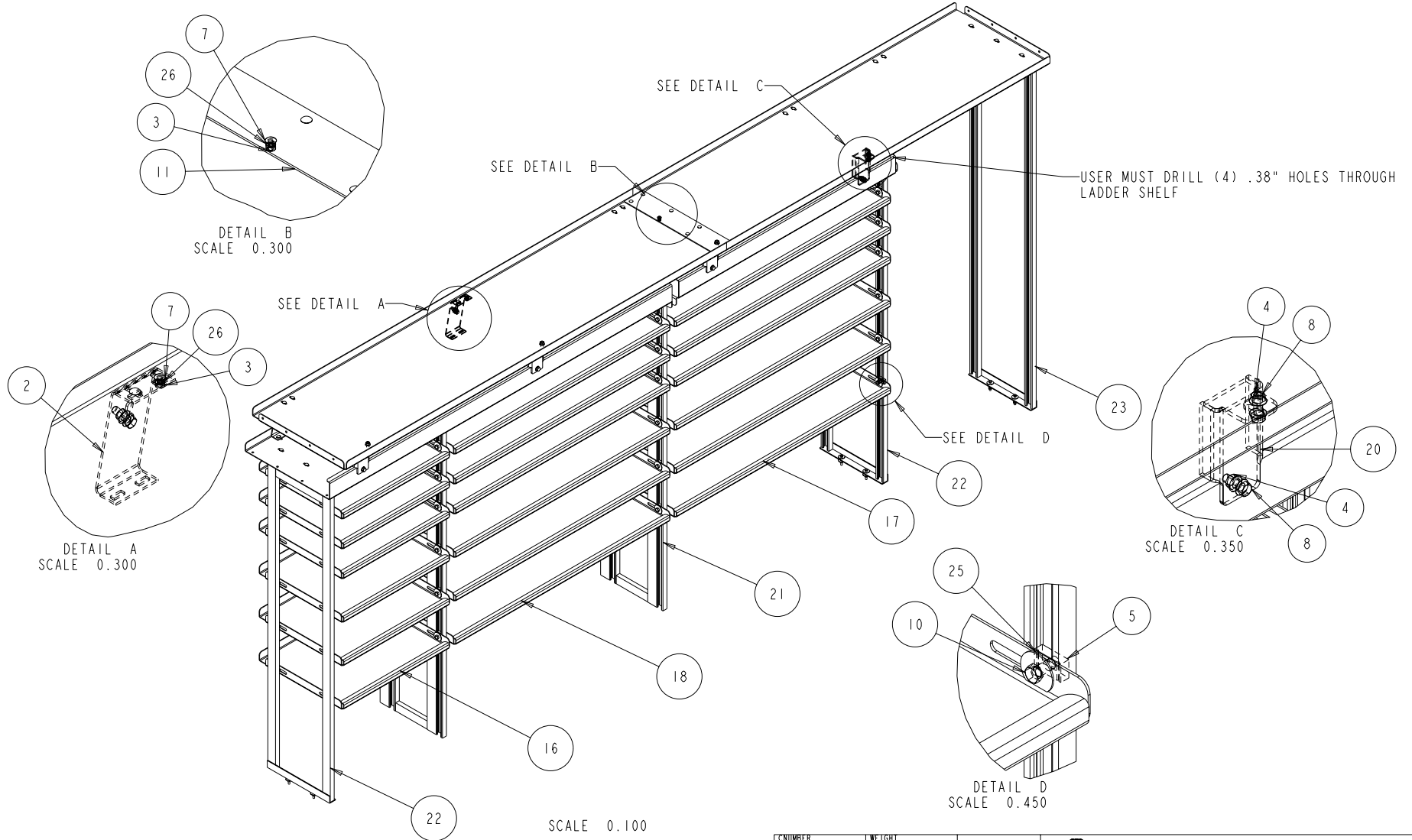
# BUILDUP DETAIL



NUMBER	SPRINTER	WEIGHT	273.479	TOLERANCE UNLESS OTHERWISE SPECIFIED	 <b>VT Hackney</b> A company of VT Systems 
ROUTING	FINAL	MATL CODE	ZA	.XX=+/- .060 XXX=+/- .030	
ITEM NO	386482	SHAPE DESC			
RAW_MATL		HRS	0.000		
DRAWN BY	ALB	DATE	05-Oct-16	DESCRIPTION	252-946-6521 vthackney.com hackney.com kidron.com vtvisioncomms.com <b>VisionComms</b>
APPROVED BY		DATE			<b>SHELF ASM- DRIVERSIDE SPRINTER 170" WB HIGH ROOF 46-46-23</b>
SUPERSEDES		SUPERSEDED BY		SCALE	0.029
				DWG NAME	P16C0530 Sheet 3 of 4

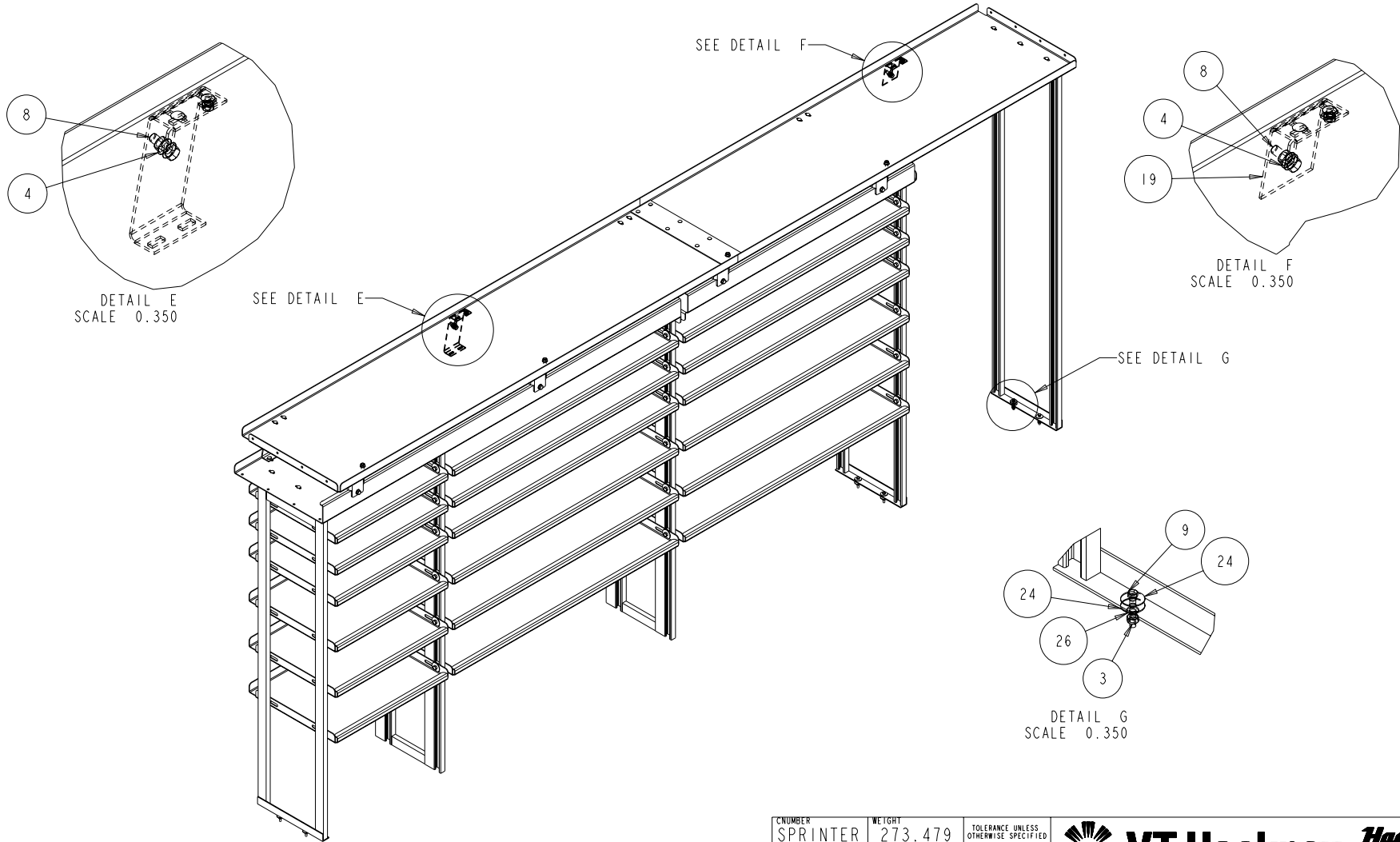

# ATTACHMENT DETAILS



SCALE 0.100

**INSTALLATION NOTES:**

- 1.) INSTALLER RESPONSIBLE FOR SECURING SHELVING UNIT TO THE VAN USING SUPPLIED HARDWARE NOTED IN DETAILS E, F, AND G.
- 2.) BEFORE DRILLING ANY HOLE THROUGH FLOOR OR WALL, VERIFY CLEARANCE ON BACKSIDE OF HOLE.

CNUMBER	WEIGHT	TOLERANCE UNLESS OTHERWISE SPECIFIED	 <b>VT Hackney</b> A company of VT Systems	
SPRINTER	273.479			
ROUTING	MATL CODE	.XX=+/- .060 XXX=+/- .030		
FINAL	ZA			
ITEM NO	SHAPE DESC		252-946-6521 vtackney.com hackney.com kidron.com vtvisioncomms.com <b>VisionComms</b>	
386482				
RAW_MATL	HRS		<b>DESCRIPTION</b> vtackney.com hackney.com kidron.com vtvisioncomms.com <b>VisionComms</b> <b>SHELF ASM- DRIVERSIDE SPRINTER 170" WB HIGH ROOF 46-46-23</b>	
	0.000			
DRAWN BY	DATE		SCALE 0.029 DWG NAME	
ALB	05-Oct-16			
APPROVED BY	DATE		<b>P16C0530 Sheet 4 of 4</b>	
SUPERSEDES	SUPERSEDED BY			