

NOTE:
 1. FOR OPTION SHELF LINER
 KIT USE, # 386465

ITEM NUMBER **386461**

BBL NO.	ITEM DESCRIPTION	LENGTH	WIDTH	WEIGHT	MATL CODE	QTY REQD	ITEM NO.	MODEL NAME
1	ANGLE-.10X1.50X1.50X 13.25	13.250	2.810	0.334	BB2	2	385287	PI5C0410
2	NUT-HEX .25 SST			0.007	E1	10	807862	807862
3	NUT-HEX .38 LK			0.018	E1	2	1485	1485
4	NUT-UNISTRUT W/O SPRING .38-16			0.086	C4	28	802807	802807
5	SCREW-CARRIAGE .25X .50			0.013	E0	6	826255	826255
6	SCREW-HEX 3/8-13X 1.00 FLANGE			0.059	E1	2	1490	1490
7	SCREW-HEX .25X1.50 SST			0.027	E0	4	803172	803172
8	SCREW-HEX .38X .75 GR5	0.750		0.043	E0	28	802804	802804
9	SHELF-TOP 18"x48.00"	48.625	18.000	10.132	BB2	1	386463	PI6C0463
10	SHELF-TRAY 18"x46"	46.000	18.000	9.633	BB2	6	385297	SHELF1_CS
11	UNISTRUT ASM-SINGLE			6.302	ZA	2	386419	386419
12	WASHER-FENDER .25 SST			0.009	E2	8	820746	820746
13	WASHER-FLAT .38 D-SHAPED PLATED			0.028	E2	28	816154	816154
14	WASHER-LOCK .25 SST			0.002	E2	10	803630	803630

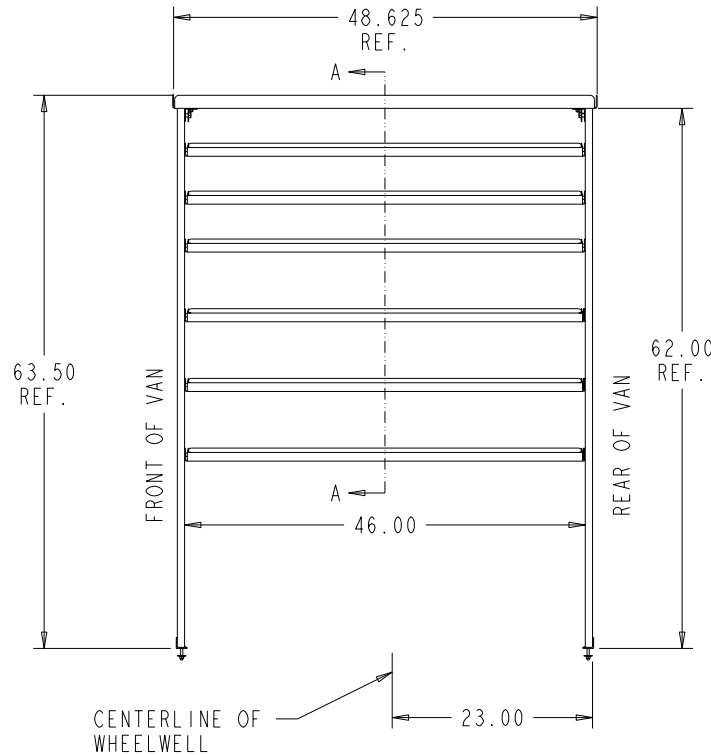

CENTERLINE OF WHEELWELL
 AT FLOOR LEVEL CURBSIDE AISLE VIEW

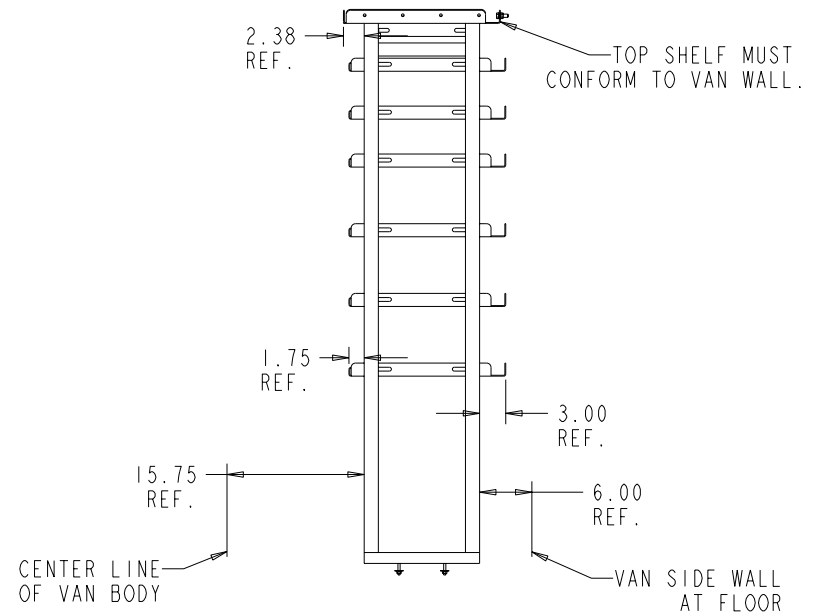

CNUMBER	SPRINTER	WEIGHT	86.106	TOLERANCE UNLESS OTHERWISE SPECIFIED
ROUTING	FINAL	MATL CODE	ZA	.XX=+/- .060 .XXX=+/- .030
ITEM NO	386461	SHAPE DESC		
RAW MATL		HRS	0.000	
DRAWN BY	LRE	DATE	31 AUG 16	
APPROVED BY		DATE		
SUPERSEDES		SUPERSEDED BY		
		SCALE	0.100	DWG NAME



252-946-6521
 vtackney.com hackney.com kidron.com vtvisioncomms.com VisionComms

SHELF ASM.- CURBSIDE SPRINTER 144"WB HIGH
 ROOF "46"

THIS PRINT AND ALL RIGHTS TO THE DESIGN AND DETAIL THEREON ARE THE PROPERTY OF VT HACKNEY AND IS LOANED TO THE RECIPIENT SUBJECT TO RETURN UPON DEMAND. ITS CONTENTS ARE CONFIDENTIAL AND MUST NOT BE COPIED OR SUBMITTED TO OUTSIDE PARTIES FOR USE OR EXAMINATION. COPYRIGHT 2016 VT HACKNEY A COMPANY OF VT SYSTEMS



REV	REVISION DESCRIPTION	ECN	DATE	INITIALS

386461

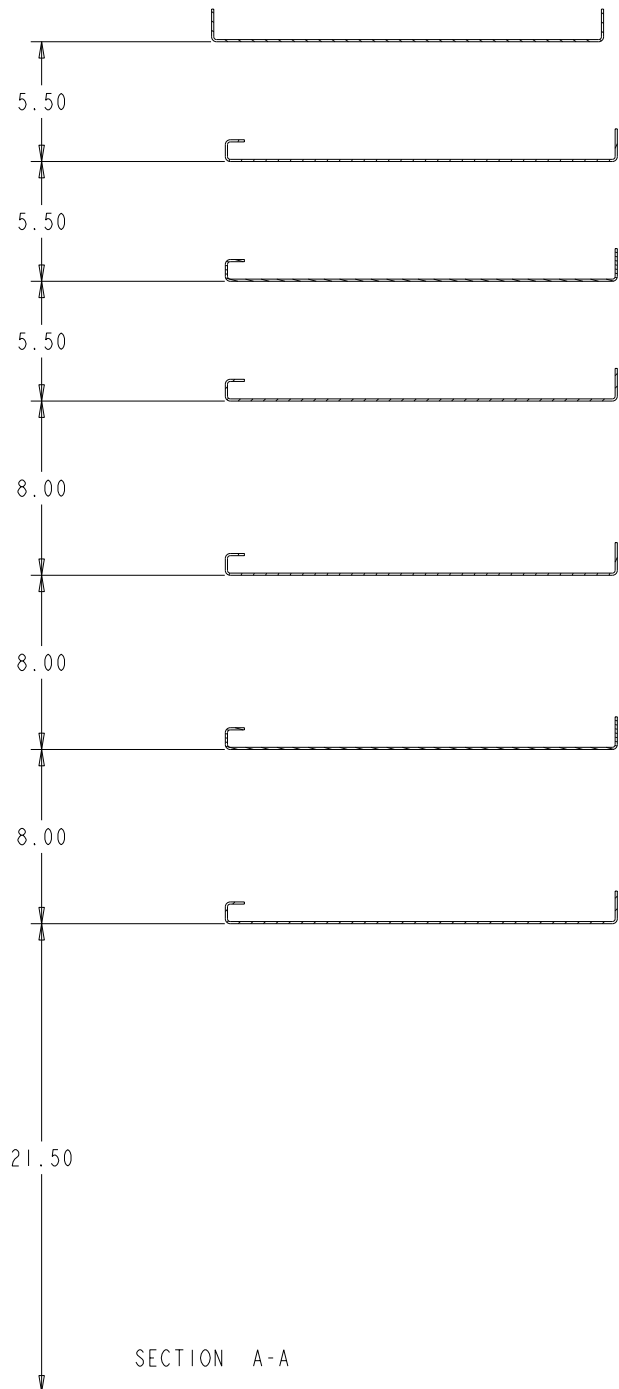
386461







SECTION A-A

CNUMBER SPRINTER	WEIGHT 86.106	TOLERANCE UNLESS OTHERWISE SPECIFIED	 VT Hackney A company of VT Systems	
ROUTING FINAL	MATL CODE ZA	.XX=+/- .060 .XXX=+/- .030		
ITEM NO 386461	SHAPE DESC		252-946-6521 vthackney.com hackney.com kidron.com vtvisioncomms.com VisionComms	
RAW_MATL	HRS 0.000	DESCRIPTION		
DRAWN BY LRE	DATE 31 AUG 16	SHELF ASM.- CURBSIDE SPRINTER 144"WB HIGH ROOF "46"		
APPROVED BY	DATE	SCALE 0.250	DWG NAME P16C0455 Sheet 2 of 4	
SUPERSEDES	SUPERSEDED BY			

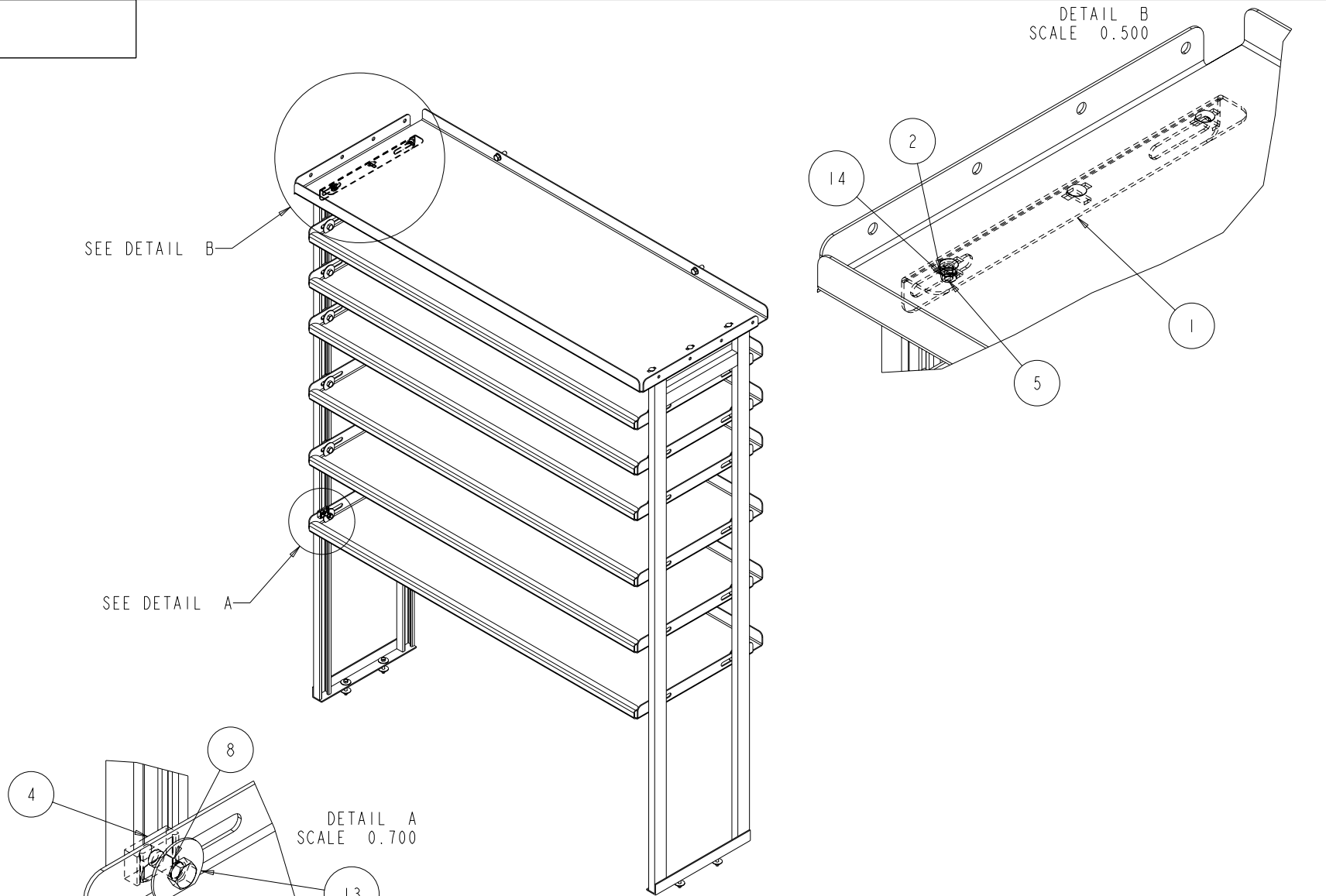
386461

386461



CNUMBER	WEIGHT	TOLERANCE UNLESS OTHERWISE SPECIFIED	 VT Hackney A company of VT Systems	
SPRINTER	86.106			
ROUTING	MATL CODE	.XX=+/- .060		
FINAL	ZA	.XXX=+/- .030		
ITEM NO	SHAPE DESC		252-946-6521 vtackney.com hackney.com kidron.com tvisioncomms.com VisionComms	
386461				
RAW_MATL	HRS	DESCRIPTION	SHELF ASM.- CURBSIDE SPRINTER 144"WB HIGH ROOF "46"	
	0.000			
DRAWN BY	DATE			
LRE	31 AUG 16		SCALE 0.150 DWG NAME	
APPROVED BY	DATE			
SUPERSEDES	SUPERSEDED BY		P16C0455 Sheet 3 of 4	

ATTACHMENT DETAILS

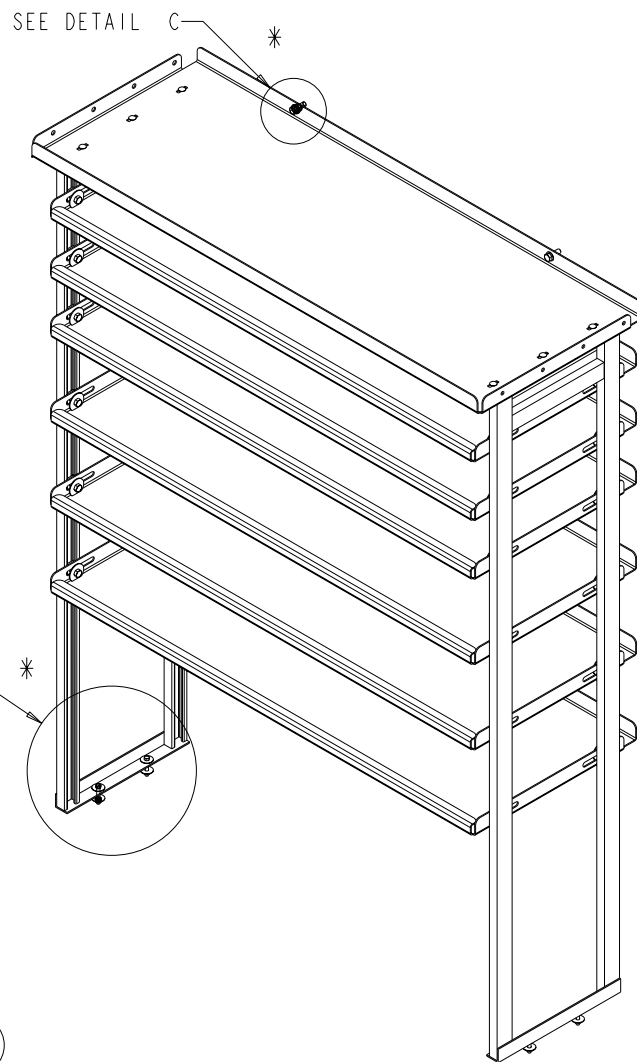

DETAIL C
SCALE 0.850

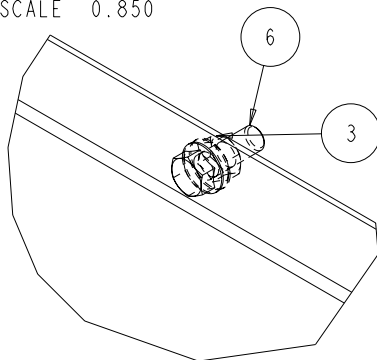

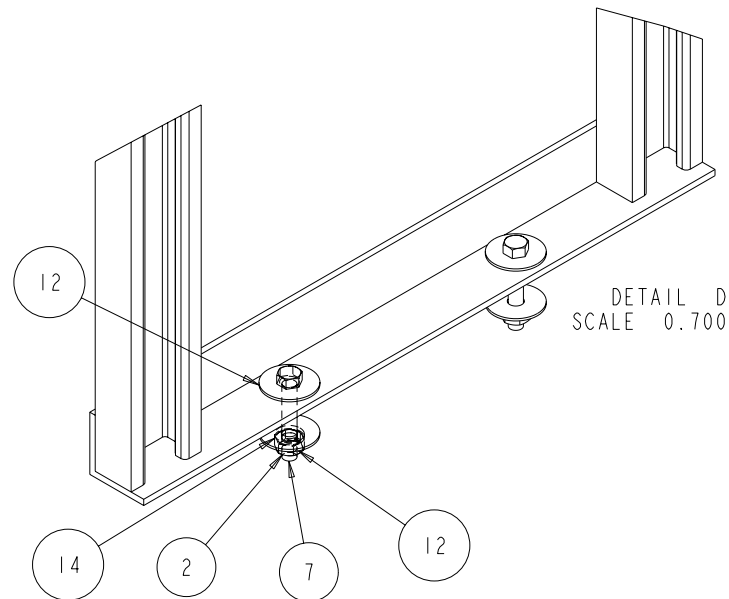

* NOTE:
BOLT THRU IN SIDE WALL
USE 3/8" DRILL THRU.



DETAIL D
SCALE 0.700

* NOTE:
BEFORE DRILLING ANY HOLE THROUGH
THE FLOOR OR WALL, VERIFY CLEARANCE
ON BACKSIDE OF HOLE.

CNUMBER SPRINTER	WEIGHT 86.106	TOLERANCE UNLESS OTHERWISE SPECIFIED	 VT Hackney A company of VT Systems	 
ROUTING FINAL	MATL CODE ZA	.XX=+/- .060 .XXX=+/- .030		
ITEM NO 386461	SHAPE DESC		252-946-6521 vtackney.com hackney.com kidron.com vtvisioncomms.com VisionComms	
RAW_MATL	HRS 0.000	DESCRIPTION SHELF ASM.- CURBSIDE SPRINTER 144"WB HIGH ROOF "46"		
DRAWN BY LRE	DATE 31 AUG 16	APPROVED BY DATE	SCALE 0.150	DWG NAME P16C0455 Sheet 4 of 4
SUPERSEDES	SUPERSEDED BY			