

NOTES:
 1. FOR OPTIONAL SHELF LINER KIT, USE #385488.

BBL NO.	ITEM DESCRIPTION	LENGTH	WIDTH	WEIGHT	MATL CODE	ITEM NUMBER		MODEL NAME
						QTY REQD	ITEM NO.	
1	ANGLE-.10X1.50X1.50X 13.25	13.250	2.810	0.334	BB2	2	385287	P15C0410
2	NUT-HEX .25 P			0.007	E1	6	1378	1378
3	NUT-HEX M8 x 1.25 SST			0.011	E1	5	820637	820637
4	NUT-UNISTRUT W/O SPRING .38-16			0.086	C4	64	802807	802807
5	SCREW-CARRIAGE .25X .50			0.014	E0	6	826255	826255
6	SCREW-HEX M8-1.25x40MM SST			0.048	E0	9	820664	820664
7	SCREW-HEX.38X .75 GR5	0.750		0.043	E0	64	802804	802804
8	SHELF-TOP 18"x48.88"	48.875	18.000	10.125	BB2	1	385478	P16C0262
9	SHELF-TOP 18"x48.88"	48.875	18.000	10.125	BB2	1	385479	P16C0263
10	SHELF-TRAY 18"x48"	48.000	18.000	10.037	BB2	14	385480	P16C0260
11	UNISTRUT ASM-DOUBLE			9.054	ZA	1	385472	385472
12	UNISTRUT ASM-SINGLE			6.188	ZA	2	385289	385289
13	WASHER-FLAT .38 D-SHAPED			0.007	E2	73	816154	816154
14	WASHER-FLAT M8 SST			0.007	E2	10	820670	820670
15	WASHER-LOCK .25			0.002	E2	6	1372	1372
16	WASHER-LOCK M8 SST			0.004	E2	9	820638	820638

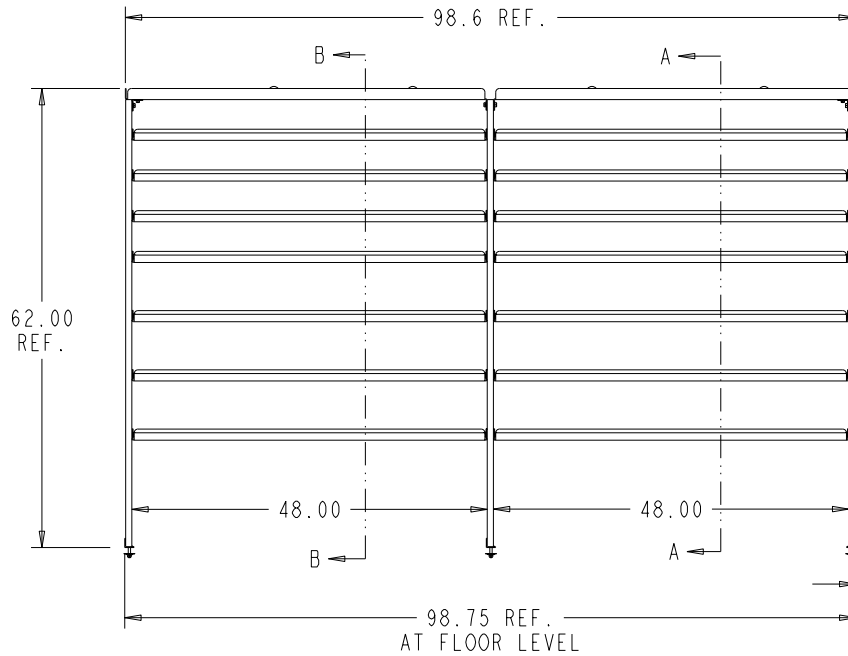

VIEWED FROM AISLE

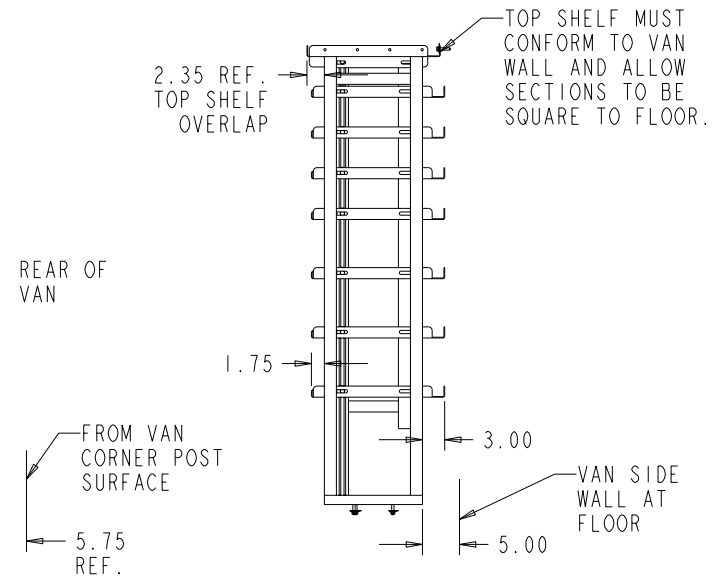

CNUMBER	WEIGHT	TOLERANCE UNLESS OTHERWISE SPECIFIED
TRANSIT	193.952	
ROUTING	MATL CODE	
FINAL	ZA	.XX=+/- .060 XXX=+/- .030
ITEM NO	SHAPE DESC	
385477		
RAW/MATL	HRS	
	0.000	
DRAWN BY	DATE	
LCS	11 APR 13	
APPROVED BY	DATE	



VT Hackney
 A company of VT Systems

Hackney



252-946-6521

vtackney.com hackney.com kidron.com vtvisioncomms.com **VisionComms**

SHELF ASM.- CURBSIDE FORD TRANSIT

THIS PRINT AND ALL RIGHTS TO THE DESIGN AND DETAIL THEREON ARE THE PROPERTY OF VT HACKNEY AND IS LOANED TO THE RECIPIENT SUBJECT TO RETURN UPON DEMAND. ITS CONTENTS ARE CONFIDENTIAL AND MUST NOT BE COPIED OR SUBMITTED TO OUTSIDE PARTIES FOR USE OR EXAMINATION. COPYRIGHT 2016 VT HACKNEY A COMPANY OF VT SYSTEMS

REV	REVISION DESCRIPTION	ECN	DATE	INITIALS

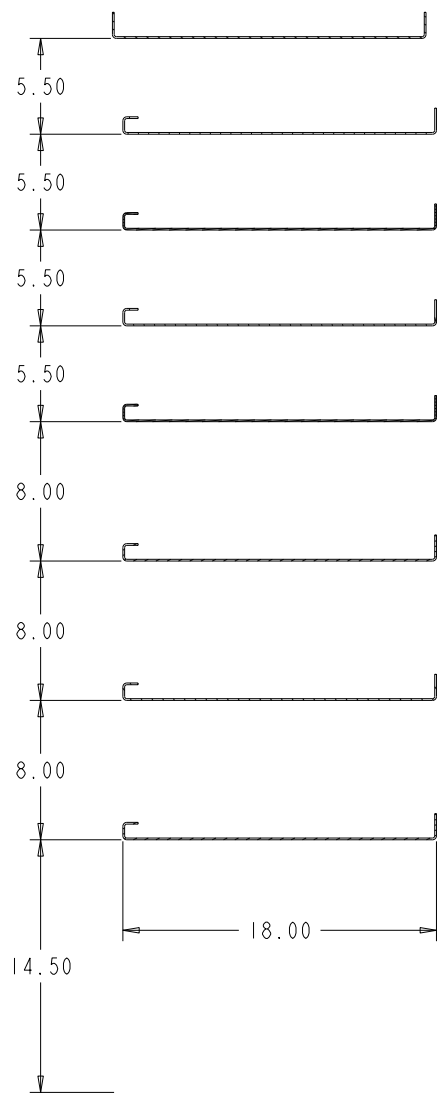

SUPERSEDES	SUPERSEDED BY	SCALE	DWG NAME
		0.085	

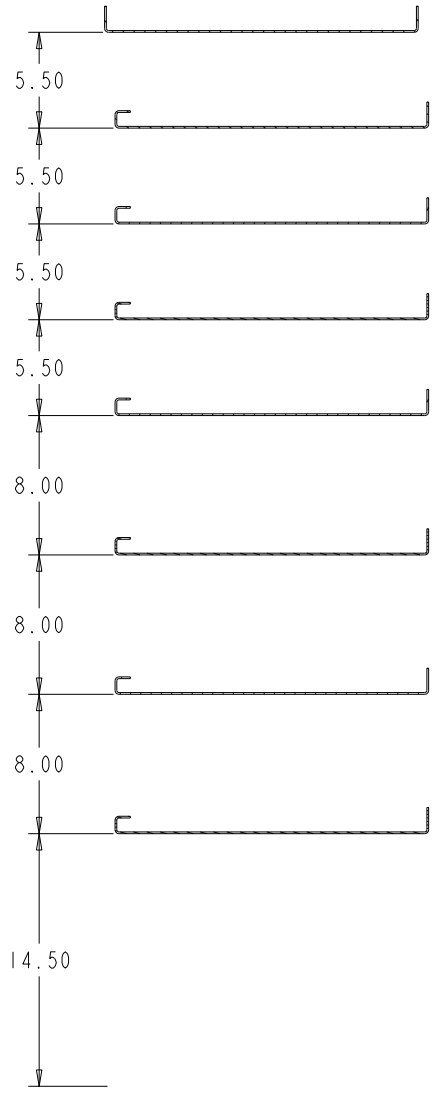

SECTION A-A



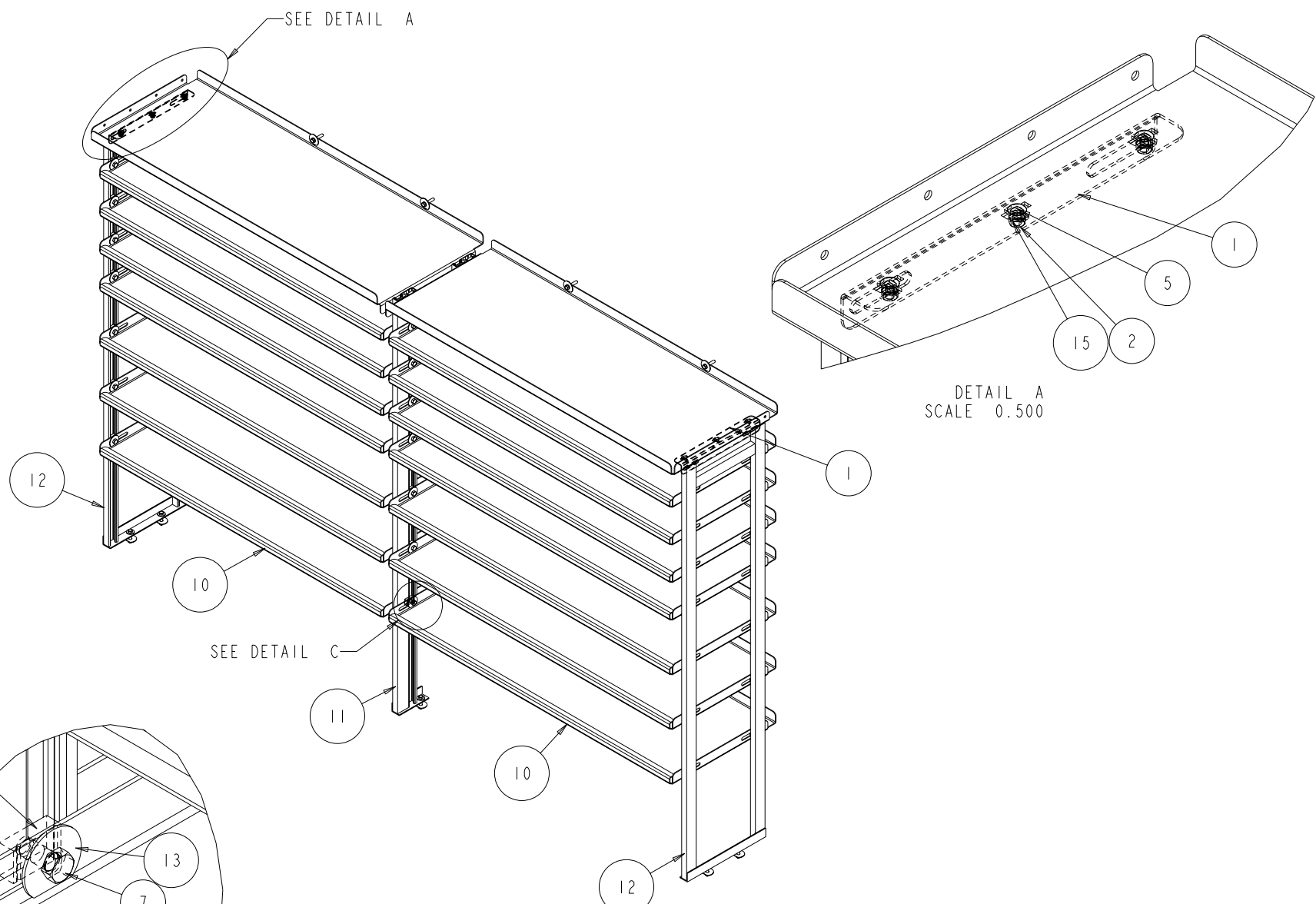

SECTION B-B

CNUMBER	WEIGHT	TOLERANCE UNLESS OTHERWISE SPECIFIED	 VT Hackney A company of VT Systems	
TRANSIT	193.952			
ROUTING	MATL CODE	.XX=+/- .060	vtackney.com hackney.com kidron.com vtvisioncomms.com	VISIONCOMMS
FINAL	ZA	.XXX=+/- .030		
ITEM NO	SHAPE DESC		DESCRIPTION	
385477			SHELF ASM.- CURBSIDE FORD TRANSIT	
RAW_MATL	HRS		252-946-6521	
	0.000			
DRAWN BY	DATE			
LCS	29-Nov-11			
APPROVED BY	DATE			
SUPERSEDES	SUPERSEDED BY	SCALE	DWG NAME	
		0.200		P16C0259 Sheet 2 of 4



TYP. SHELF HARDWARE
DETAIL C
SCALE 0.800

CNUMBER	WEIGHT	TOLERANCE UNLESS OTHERWISE SPECIFIED	 VT Hackney A company of VT Systems	 
TRANSIT	193.952			
ROUTING	MATL CODE	.XX=+/- .060	252-946-6521 vtackney.com hackney.com kidron.com vtvisioncomms.com	VISIONCOMMS
FINAL	ZA	XXX=+/- .030		
ITEM NO	SHAPE DESC		DESCRIPTION	
385477			SHELF ASM.- CURBSIDE FORD TRANSIT	
RAW_MATL	HRS		SCALE	DWG NAME
	0.000		0.125	P16C0259 Sheet 3 of 4
DRAWN BY	DATE			
LCS	29-Nov-11			
APPROVED BY	DATE			
SUPERSEDES	SUPERSEDED BY			

ATTACHMENT DETAILS

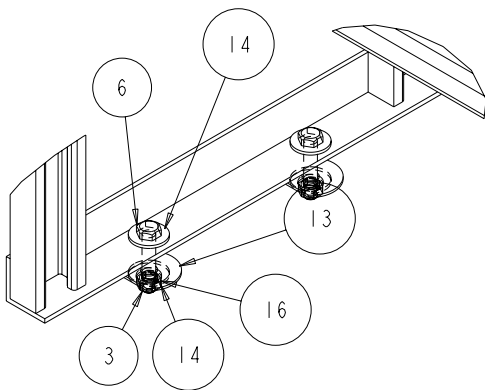
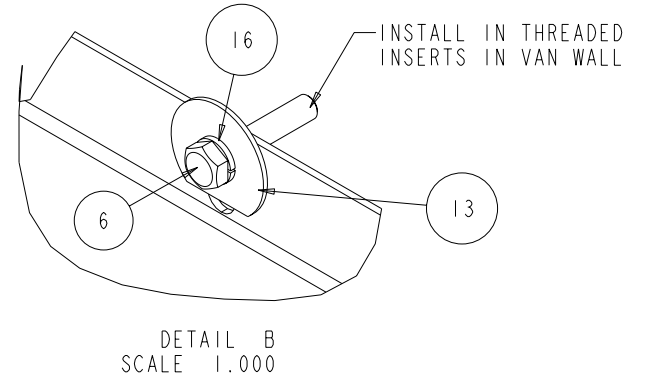
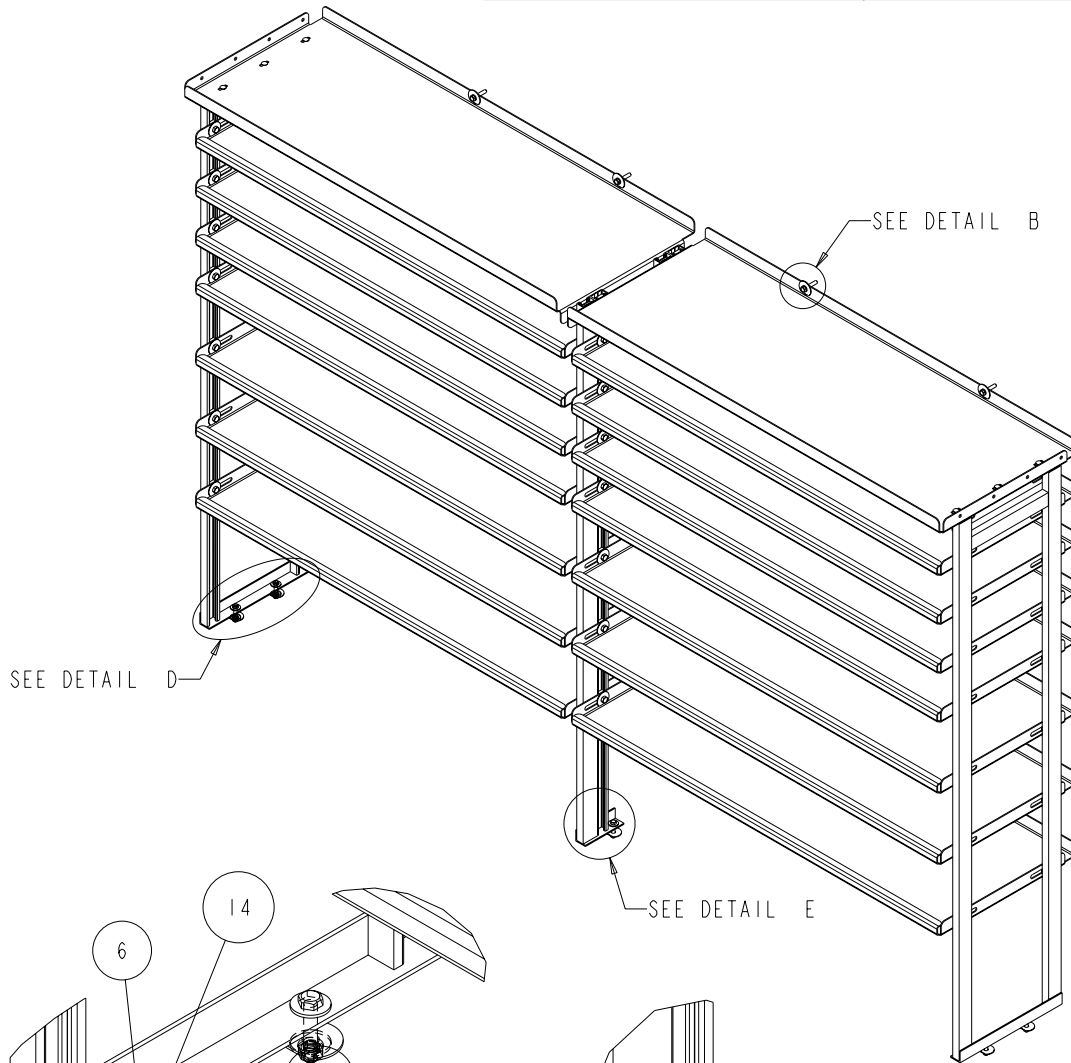

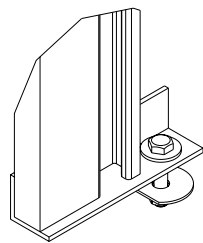

DETAIL D
SCALE 0.500
BOLT THRU FLOOR



DETAIL E
SCALE 0.500
BOLT THRU FLOOR

**NOTE:
BEFORE DRILLING ANY HOLE THROUGH
THE FLOOR OR WALL, VERIFY CLEARANCE
ON BACKSIDE OF HOLE.**

CNUMBER TRANSIT	WEIGHT 193.952	TOLERANCE UNLESS OTHERWISE SPECIFIED	 VT Hackney A company of VT Systems	 
ROUTING FINAL	MATL CODE ZA	.XX=+/- .060 XXX=+/- .030		
ITEM NO 385477	SHAPE DESC		252-946-6521 vtackney.com hackney.com kidron.com vtvisioncomms.com VisionComms	
RAW_MATL	HRS 0.000	DESCRIPTION	SHELF ASM.- CURBSIDE FORD TRANSIT	
DRAWN BY LCS	DATE 29-Nov-11	APPROVED BY	SCALE 0.125	DWG NAME P16C0259 Sheet 4 of 4
SUPERSEDES	SUPERSEDED BY			