

BBL NO.	ITEM DESCRIPTION	LENGTH	WIDTH	WEIGHT	MATL CODE	QTY REQD	ITEM NO.	MODEL NAME
1	ANGLE-.10X1.50X1.50X 13.25	13.250	2.810	0.334	BB2	2	385287	P15C0410
2	NUT-HEX .25 P			0.007	E1	6	1378	1378
3	NUT-HEX M8 x 1.25 SST			0.011	E1	4	820637	820637
4	NUT-UNISTRUT W/O SPRING .38-16			0.086	C4	28	802807	802807
5	SCREW-CARRIAGE .25X .75			0.018	E0	6	1430	1430
6	SCREW-HEX M8-1.25x40MM SST			0.048	E0	6	820664	820664
7	SCREW-HEX.38X .75 GR5	0.750		0.043	E0	28	802804	802804
8	SHELF-TOP 20"x50.25"	50.250	20.000	11.437	BB2	1	386272	P15C0665
9	SHELF-TRAY 18"x46"	46.000	18.000	9.633	BB2	6	385297	P15C0419
10	UNISTRUT ASM-SINGLE REAR CS			6.188	ZA	2	385352	385352
11	WASHER-FLAT .38 D-SHAPED			0.007	E2	32	816154	816154
12	WASHER-FLAT M8 SST			0.007	E2	8	820670	820670
13	WASHER-LOCK .25			0.002	E2	6	1372	1372
14	WASHER-LOCK M8 SST			0.004	E2	6	820638	820638

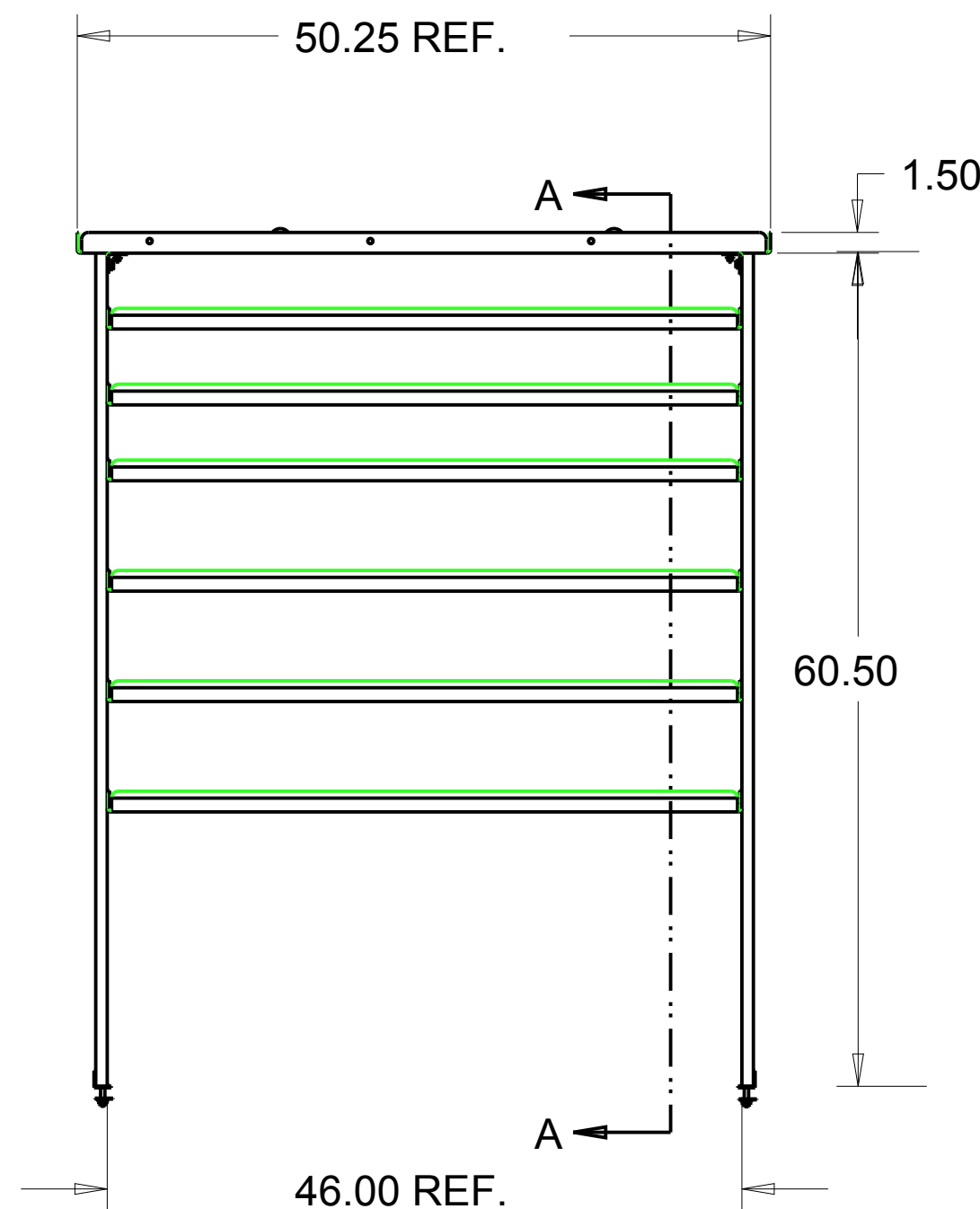

VIEWED FROM AISLE

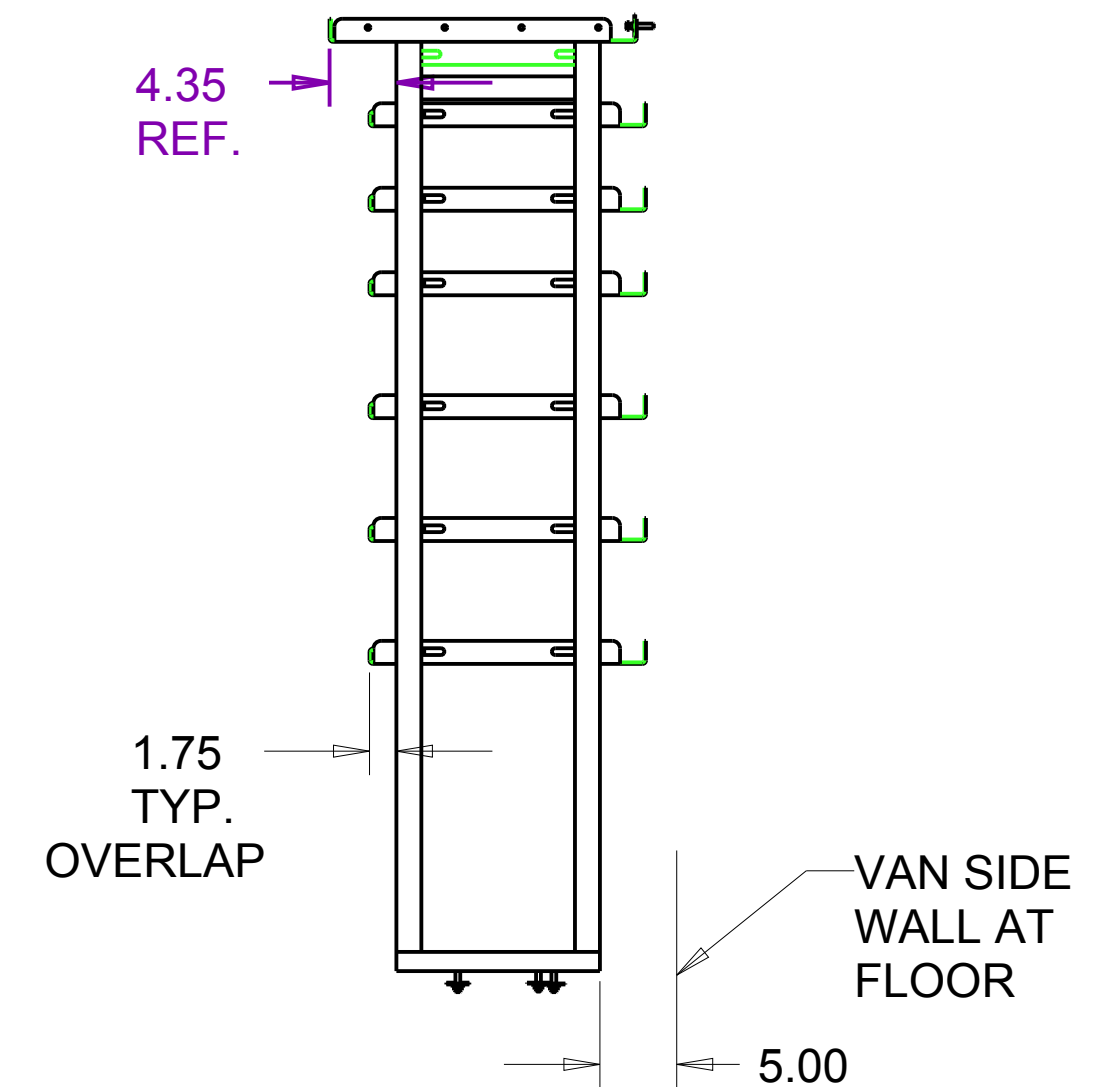

NUMBER	TRANSIT	WEIGHT	87.059	TOLERANCE UNLESS OTHERWISE SPECIFIED	
ROUTING	FINAL	MATL CODE	ZA	.XX=+/- .060	
ITEM NO	386276	SHAPE DESC		.XXX=+/- .030	
RAW_MATL		HRS	0.000	DESCRIPTION	vtackney.com hackney.com kidron.com vtvisioncomms.com
DRAWN BY	LRE	DATE	Dec-08-15	SHELF ASM.-CURBSIDE FORD TRANSIT SHELF OPTIO	
APPROVED BY		DATE		"46" 130"WB MED ROOF	
SUPERSEDES		SUPERSEDED BY		SCALE	0.080
				DWG NAME	P15C0668 Sheet 1 of 4



THIS PRINT AND ALL RIGHTS TO THE DESIGN AND DETAIL THEREON ARE THE PROPERTY OF VT HACKNEY AND IS LOANED TO THE RECIPIENT SUBJECT TO RETURN UPON DEMAND. ITS CONTENTS ARE CONFIDENTIAL AND MUST NOT BE COPIED OR SUBMITTED TO OUTSIDE PARTIES FOR USE OR EXAMINATION. COPYRIGHT 2015 VT HACKNEY A COMPANY OF VT SYSTEMS

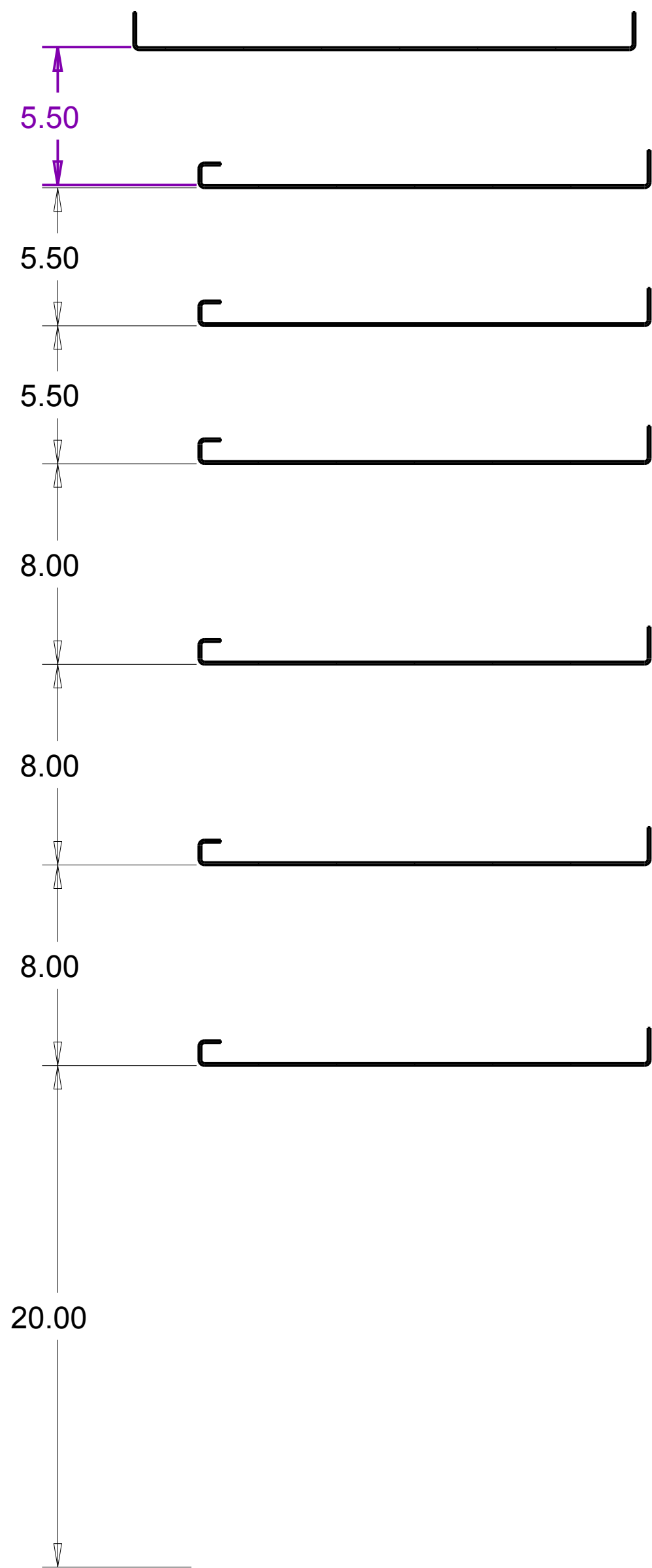

REV	REVISION DESCRIPTION	ECN	DATE	INITIALS



SECTION A-A

THIS PRINT AND ALL RIGHTS TO THE DESIGN AND DETAIL THEREON ARE THE PROPERTY OF VT HACKNEY AND IS LOANED TO THE RECIPIENT SUBJECT TO RETURN UPON DEMAND. ITS CONTENTS ARE CONFIDENTIAL AND MUST NOT BE COPIED OR SUBMITTED TO OUTSIDE PARTIES FOR USE OR EXAMINATION. COPYRIGHT 2015 VT HACKNEY A COMPANY OF VT SYSTEMS

REV	REVISION DESCRIPTION	ECN	DATE	INITIALS

CNUMBER TRANSIT	WEIGHT 87.059	TOLERANCE UNLESS OTHERWISE SPECIFIED	
ROUTING FINAL	MATL CODE ZA	.XX=+/- .060	 A company of VT Systems  
ITEM NO 386276	SHAPE DESC	.XXX=+/- .030	
RAW_MATL	HRS 0.000	DESCRIPTION	vthackney.com hackney.com kidron.com vtvisioncomms.com
DRAWN BY LRE	DATE Dec-08-15	SHELF ASM.-CURBSIDE FORD TRANSIT SHELF OPTIO	
APPROVED BY	DATE	"46" 130"WB MED ROOF	
SUPERSEDES	SUPERSEDED BY	SCALE 0.200	DWG NAME P15C0668 Sheet 2 of 4

252-946-6521

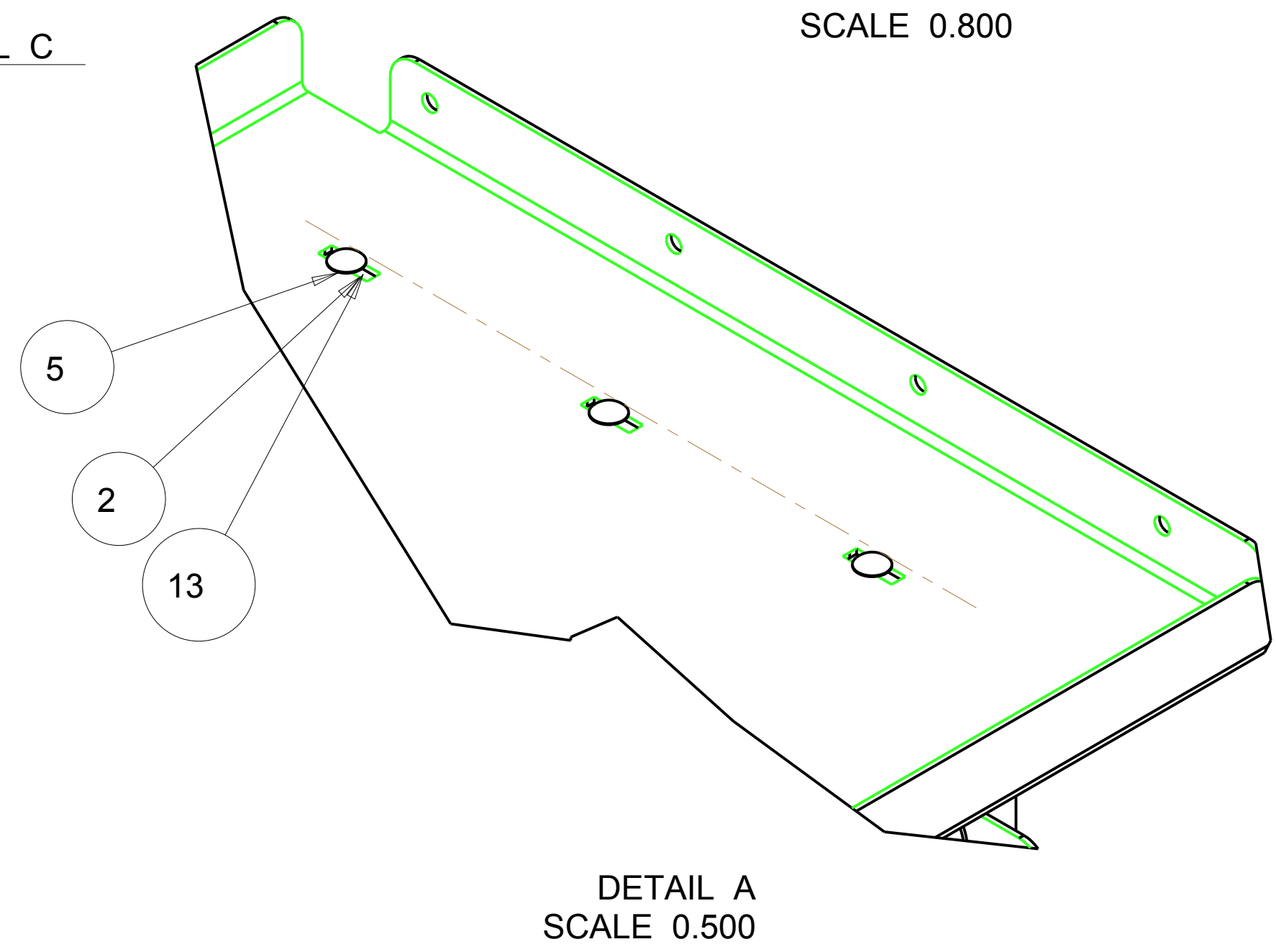
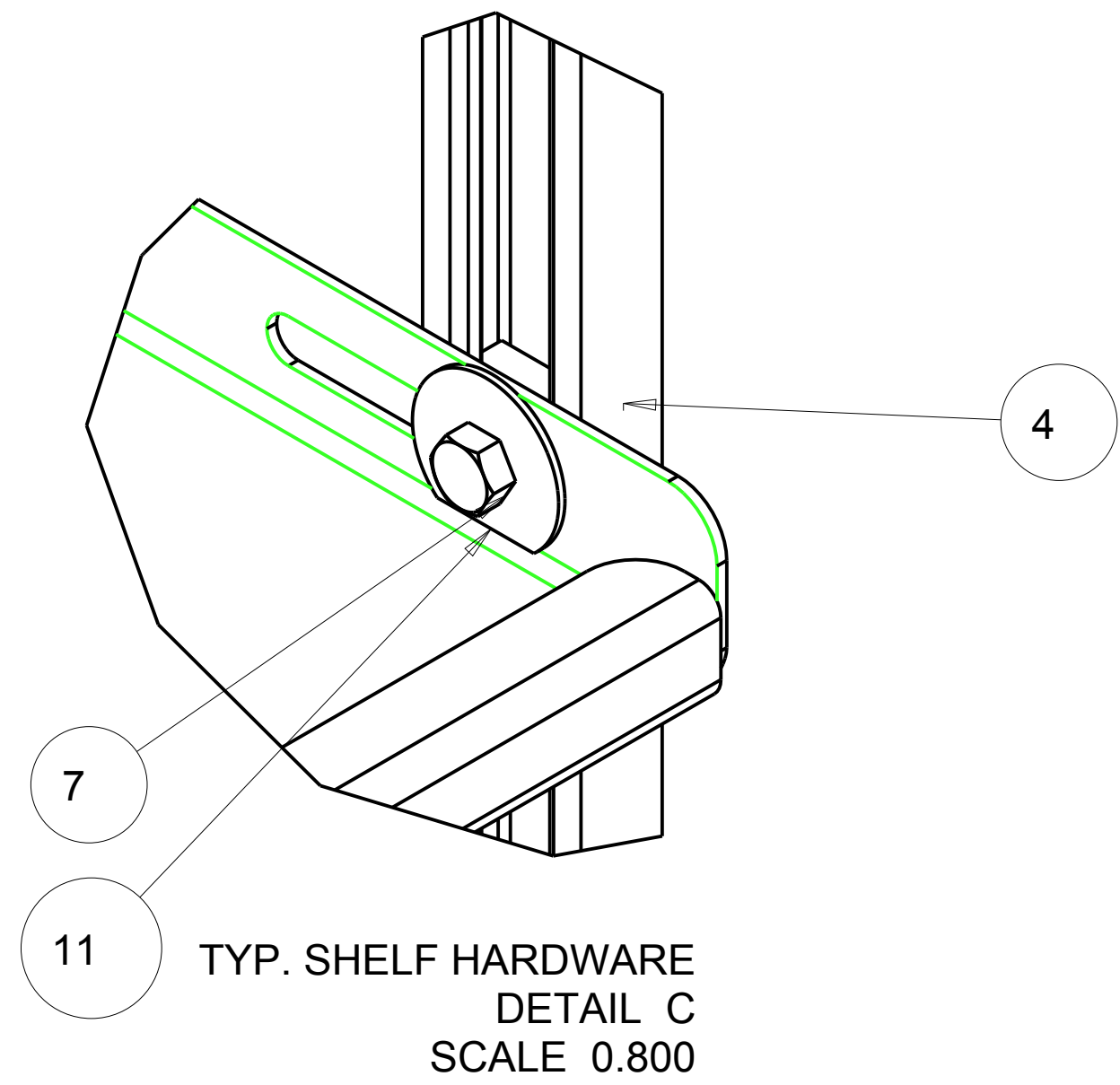
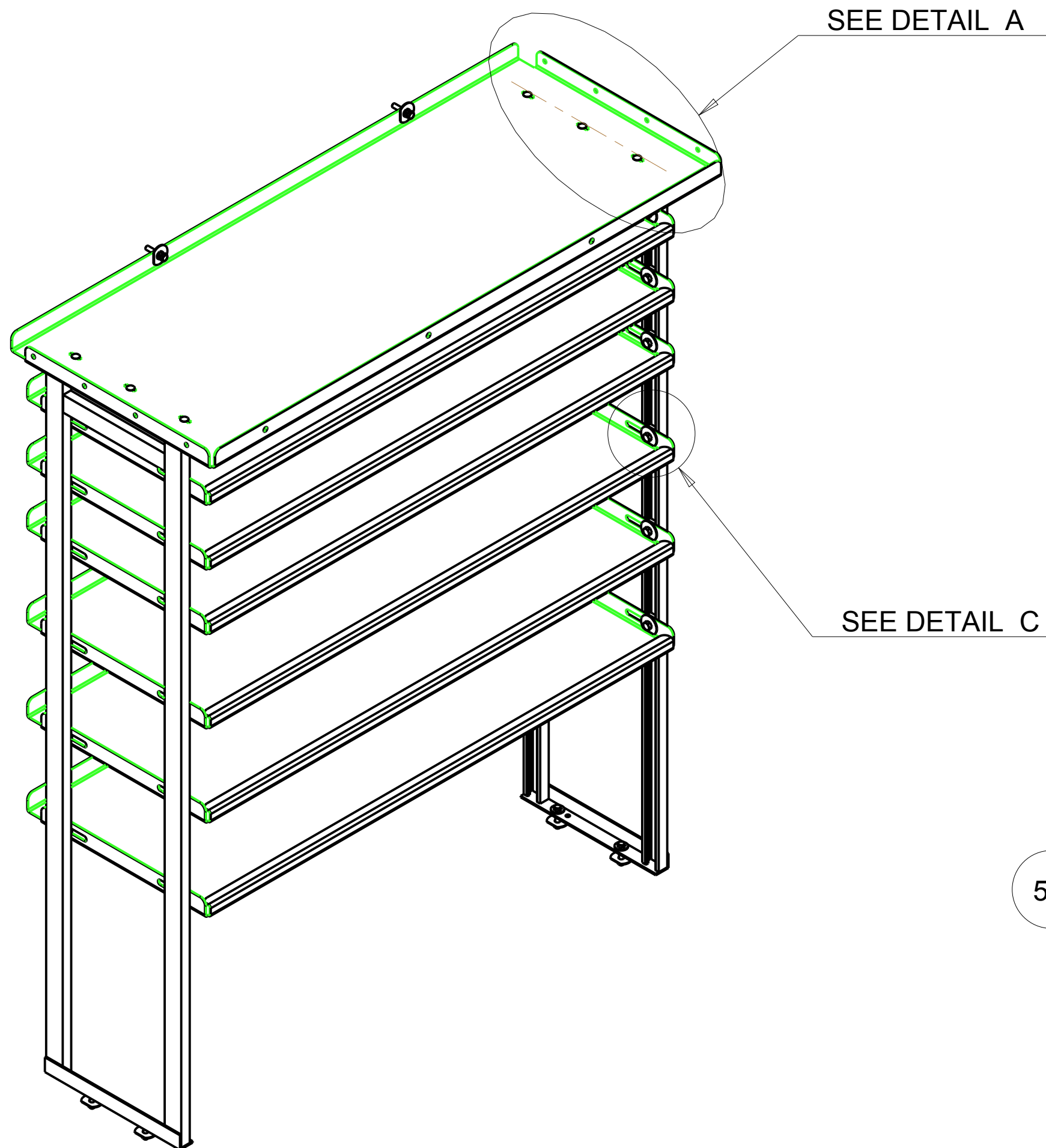

THIS PRINT AND ALL RIGHTS TO THE DESIGN AND DETAIL THEREON ARE THE PROPERTY OF VT HACKNEY AND IS LOANED TO THE RECIPIENT SUBJECT TO RETURN UPON DEMAND. ITS CONTENTS ARE CONFIDENTIAL AND MUST NOT BE COPIED OR SUBMITTED TO OUTSIDE PARTIES FOR USE OR EXAMINATION. COPYRIGHT 2015 VT HACKNEY A COMPANY OF VT SYSTEMS

REV	REVISION DESCRIPTION	ECN	DATE	INITIALS

CNUMBER <b>TRANSIT</b>	WEIGHT <b>87.059</b>	TOLERANCE UNLESS OTHERWISE SPECIFIED
ROUTING <b>FINAL</b>	MATL CODE <b>ZA</b>	.XX=+/- .060 .XXX=+/- .030
ITEM NO <b>386276</b>	SHAPE DESC	
RAW_MATL	HRS <b>0.000</b>	
DRAWN BY <b>LRE</b>	DATE <b>Dec-08-15</b>	DESCRIPTION
APPROVED BY	DATE	<b>"46" 130"WB MED ROOF</b>
SUPERSEDES	SUPERSEDED BY	SCALE <b>0.125</b>
		DWG NAME <b>P15C0668 Sheet 3 of 4</b>



**VT Hackney**  
A company of VT Systems

252-946-6521  
vthackney.com hackney.com kidron.com vtvisioncomms.com



**VisionComms**

# ATTACHMENT DETAILS

BOLT TO OEM WALL  
INSERTS (2) LOCATIONS

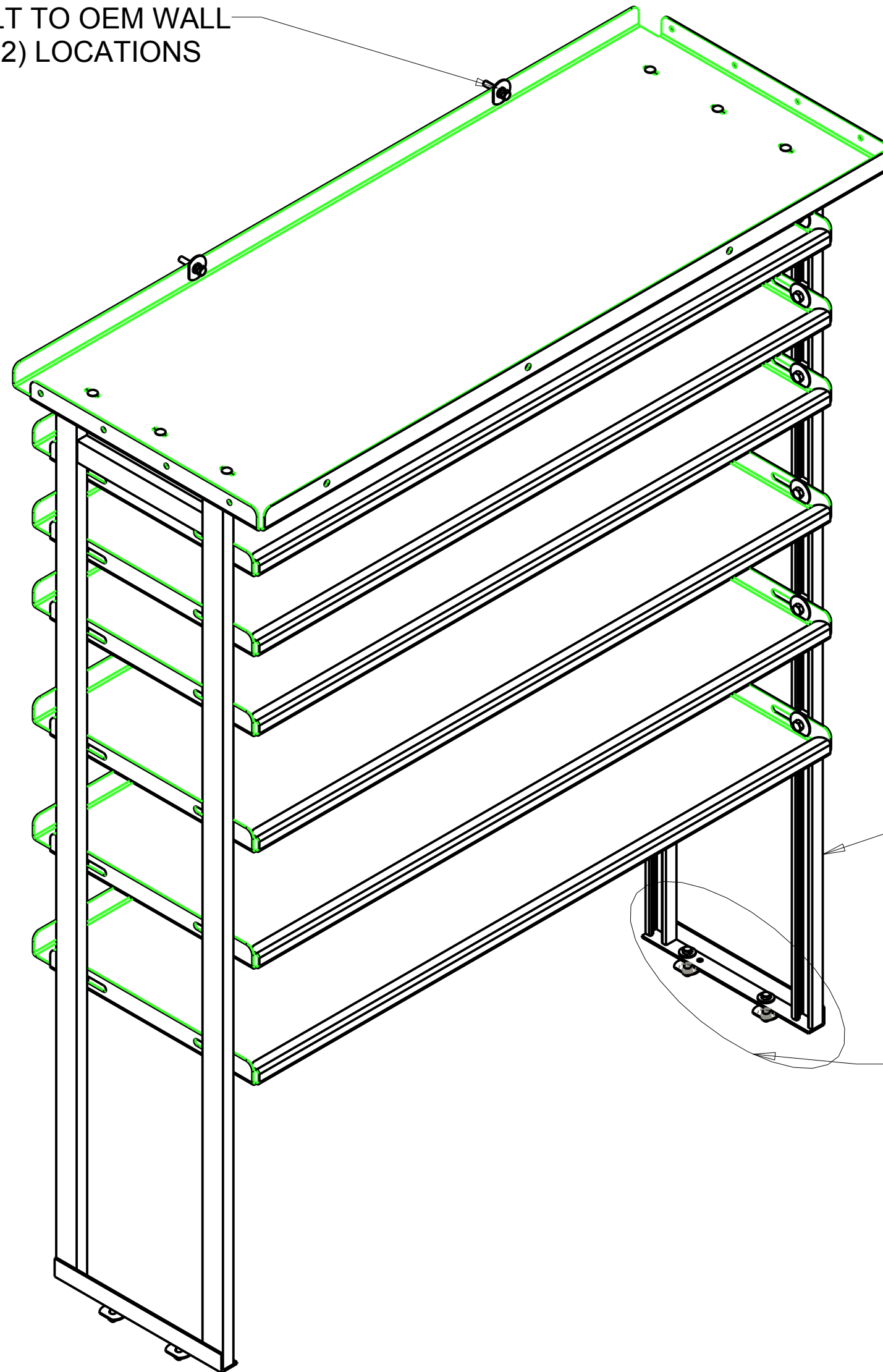

REAR OF  
VAN

NOTE: VERIFY THIS  
IS THE CORRECT REAR  
SECTION WITH HOLE

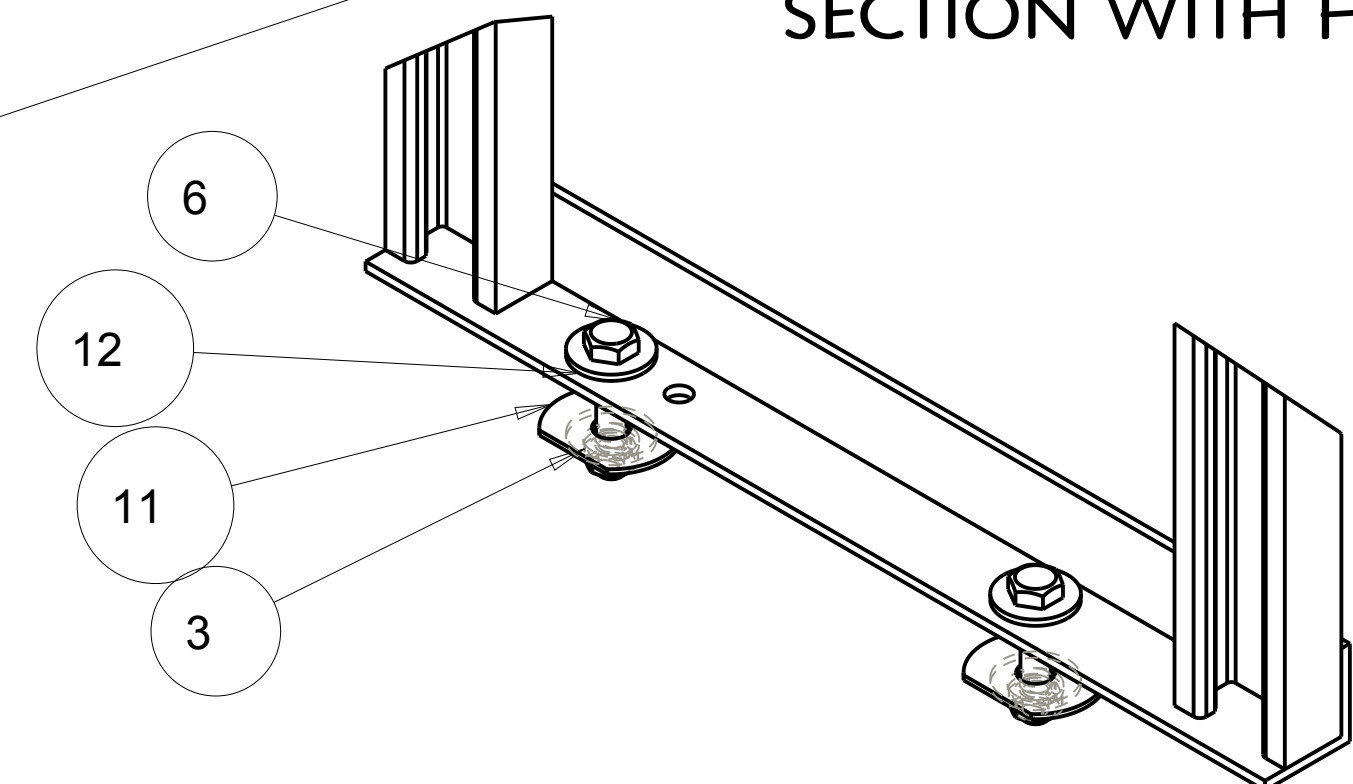

SEE DETAIL B

FRONT OF  
VAN

DETAIL B  
SCALE 0.500  
TYPICAL BOLT  
THRU FLOOR  
AT REAR

THIS PRINT AND ALL RIGHTS TO THE DESIGN AND DETAIL THEREON ARE THE PROPERTY OF VT HACKNEY AND IS LOANED TO THE RECIPIENT SUBJECT TO RETURN UPON DEMAND. ITS CONTENTS ARE CONFIDENTIAL AND MUST NOT BE COPIED OR SUBMITTED TO OUTSIDE PARTIES FOR USE OR EXAMINATION. COPYRIGHT 2015 VT HACKNEY A COMPANY OF VT SYSTEMS

REV	REVISION DESCRIPTION	ECN	DATE	INITIALS

CNUMBER <b>TRANSIT</b>	WEIGHT <b>87.059</b>	TOLERANCE UNLESS OTHERWISE SPECIFIED
ROUTING <b>FINAL</b>	MATL CODE <b>ZA</b>	.XX=+/-_.060 .XXX=+/-_.030
ITEM NO <b>386276</b>	SHAPE DESC	
RAW_MATL	HRS <b>0.000</b>	
DRAWN BY <b>LRE</b>	DATE <b>Dec-08-15</b>	DESCRIPTION
APPROVED BY	DATE	<b>SHELF ASM.-CURBSIDE FORD TRANSIT SHELF OPTIO "46" 130"WB MED ROOF</b>
SUPERSEDES	SUPERSEDED BY	SCALE <b>0.150</b>

**VT Hackney** *Hackney*  
 A company of VT Systems

252-946-6521  
 vtackney.com hackney.com kidron.com vtvisioncomms.com

