

BBL NO.	ITEM DESCRIPTION	LENGTH	WIDTH	WEIGHT	MATL CODE	QTY REQD	ITEM NO.	MODEL NAME
1	ANGLE-.10X1.50X1.50X 13.25	13.250	2.810	0.334	BB2	2	385287	P15C0410
2	NUT-HEX .25 P			0.007	E1	6	1378	1378
3	NUT-HEX M8 x 1.25 SST			0.011	E1	4	820637	820637
4	NUT-UNISTRUT W/O SPRING .38-16			0.086	C4	56	802807	802807
5	SCREW-CARRIAGE .25X .75			0.018	E0	6	1430	1430
6	SCREW-HEX M8-1.25x40MM SST			0.048	E0	8	820664	820664
7	SCREW-HEX.38X .75 GR5	0.750		0.043	E0	56	802804	802804
8	SHELF-TOP 18"x46.88"	46.875	18.000	9.757	BB2	1	386274	P15C0670
9	SHELF-TOP 18"x48.25"	48.250	18.000	10.040	BB2	1	386275	P15C0671
10	SHELF-TRAY 18"x46"	46.000	18.000	9.633	BB2	12	385297	P15C0419
11	UNISTRUT ASM-DOUBLE			9.386	ZA	1	385288	385288
12	UNISTRUT ASM-SINGLE			6.188	ZA	1	385289	385289
13	UNISTRUT ASM-SINGLE REAR DS			6.186	ZA	1	385354	385354
14	WASHER-FLAT .38 D-SHAPED			0.007	E2	64	816154	816154
15	WASHER-FLAT M8 SST			0.007	E2	8	820670	820670
16	WASHER-LOCK .25			0.002	E2	6	1372	1372
17	WASHER-LOCK M8 SST			0.004	E2	8	820638	820638

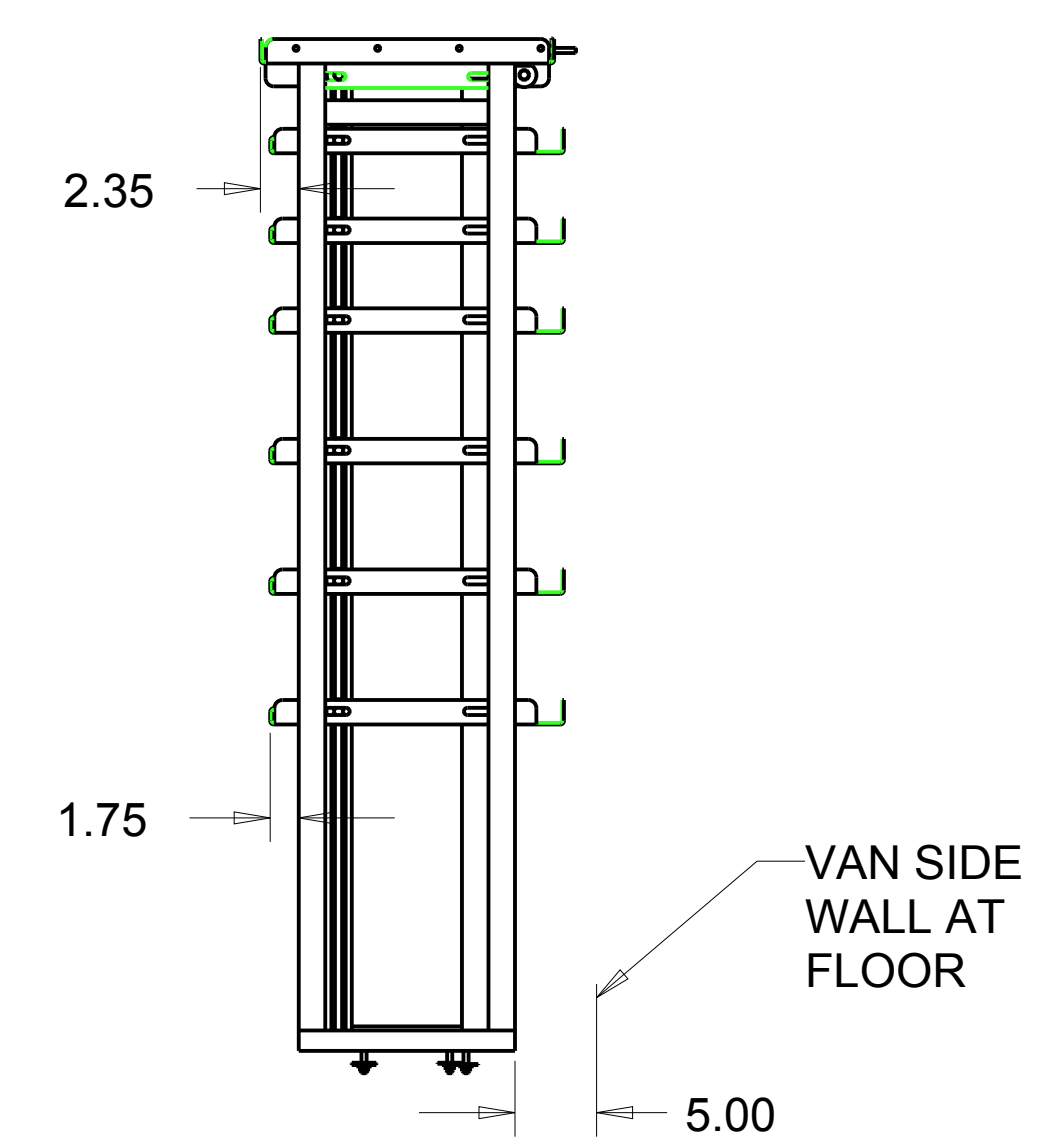
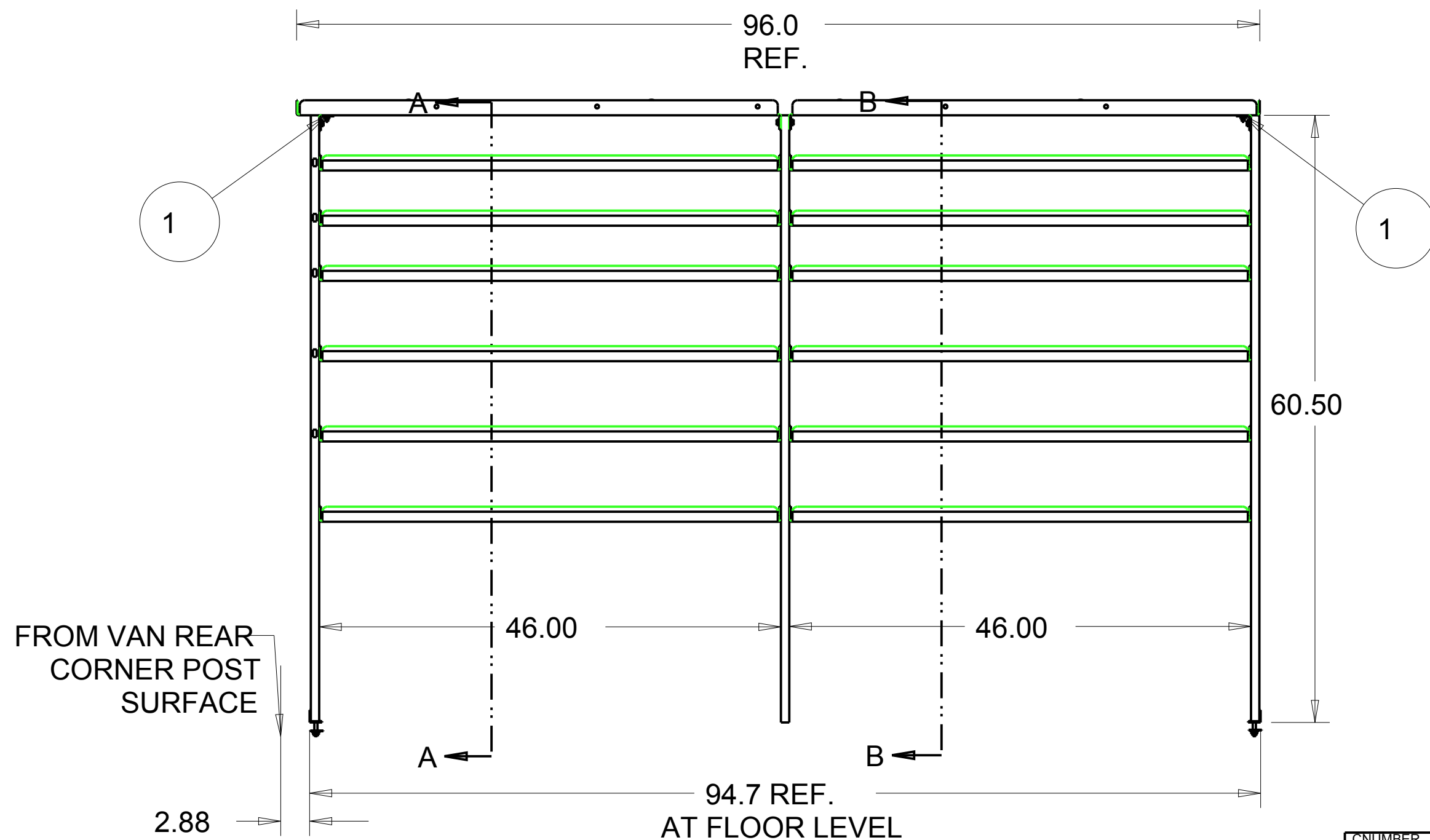

VIEWED FROM AISLE

NUMBER	TRANSIT	WEIGHT	167.522	TOLERANCE UNLESS OTHERWISE SPECIFIED	
ROUTING	FINAL	MATL CODE	ZA	.XX=+/- .060	
ITEM NO	386273	SHAPE DESC		.XXX=+/- .030	
RAW_MATL		HRS	0.000	DESCRIPTION	vthackney.com hackney.com kidron.com vtvisioncomms.com
DRAWN BY	LRE	DATE	Dec-03-15		
APPROVED BY		DATE			
SUPERSEDES		SUPERSEDED BY		SCALE	0.085
				DWG NAME	P15C0669 Sheet 1 of 4

VT Hackney *Hackney*
A company of VT Systems

Kidron

252-946-6521
vthackney.com hackney.com kidron.com vtvisioncomms.com **VisionComms**

SHELF ASM.- DRIVERSIDE FORD TRANSIT SHELF OPTION "46-46" 130"WB MED ROOF

THIS PRINT AND ALL RIGHTS TO THE DESIGN AND DETAIL THEREON ARE THE PROPERTY OF VT HACKNEY AND IS LOANED TO THE RECIPIENT SUBJECT TO RETURN UPON DEMAND. ITS CONTENTS ARE CONFIDENTIAL AND MUST NOT BE COPIED OR SUBMITTED TO OUTSIDE PARTIES FOR USE OR EXAMINATION. COPYRIGHT 2015 VT HACKNEY A COMPANY OF VT SYSTEMS

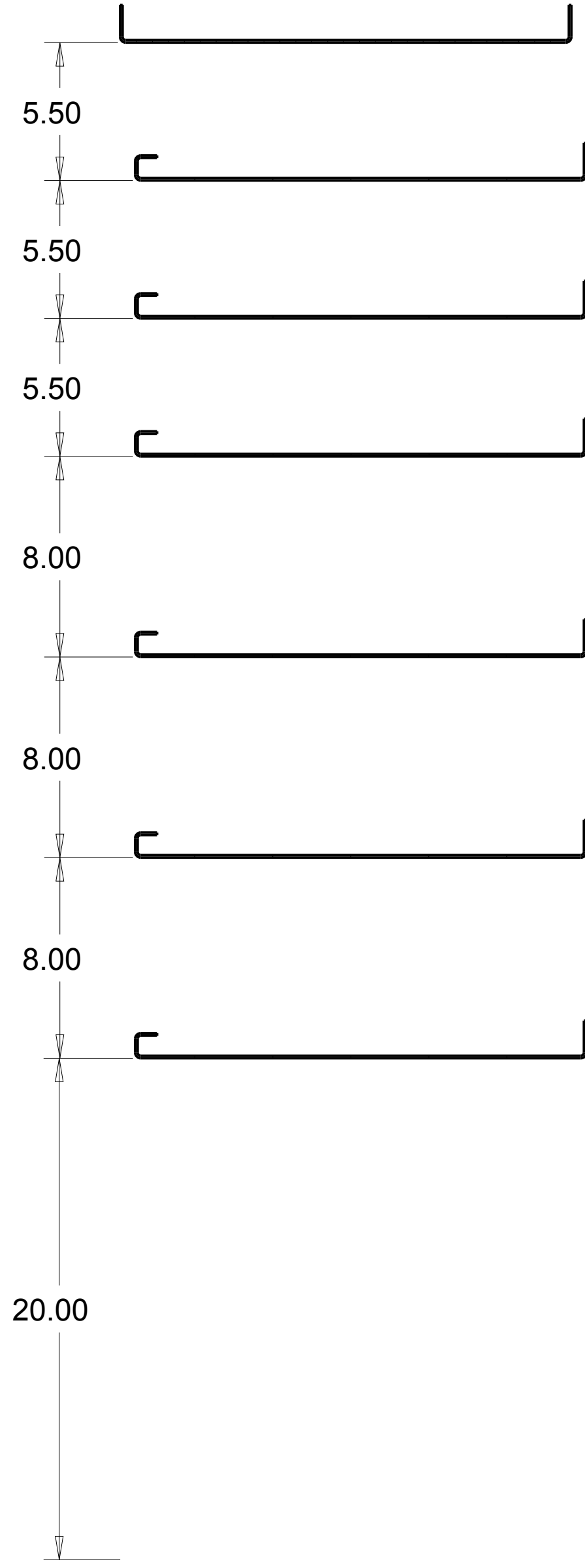

REV	REVISION DESCRIPTION	ECN	DATE	INITIALS

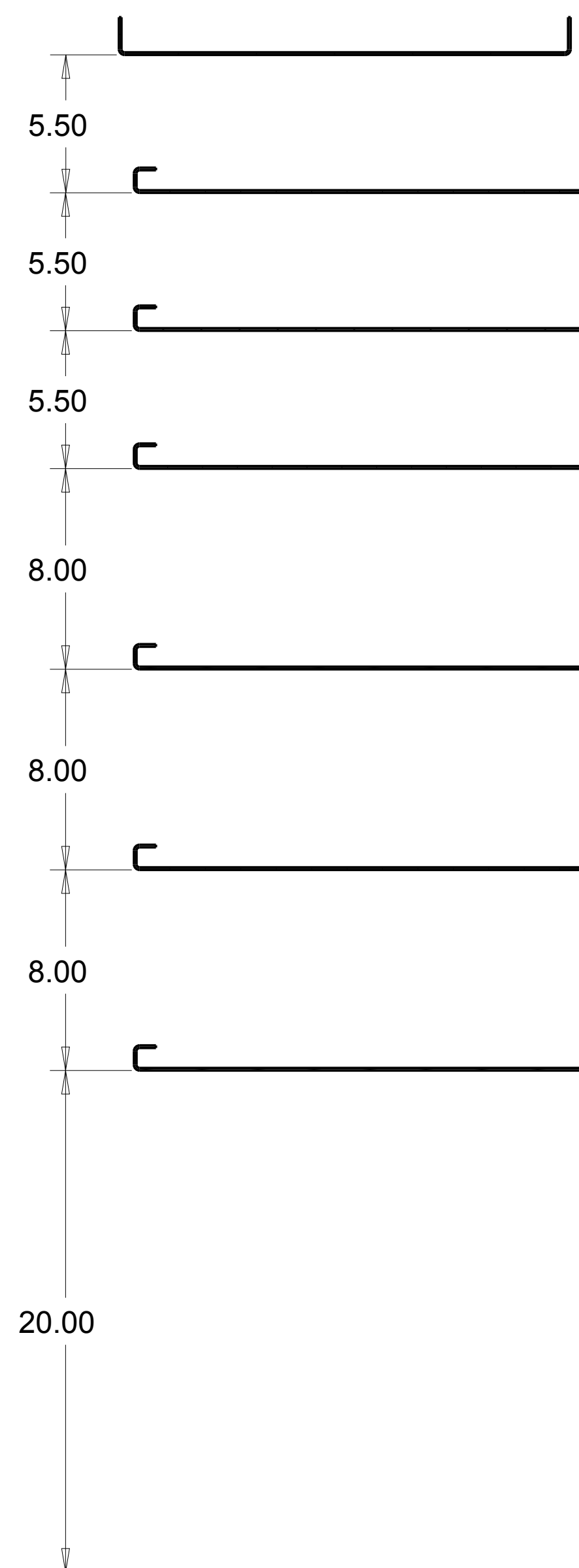

SECTION A-A



SECTION B-B

CNUMBER TRANSIT	WEIGHT 167.522	TOLERANCE UNLESS OTHERWISE SPECIFIED	 A company of VT Systems 252-946-6521 vtackney.com hackney.com kidron.com vtvisioncomms.com  VisionComms
ROUTING FINAL	MATL CODE ZA	.XX=+/- .060 .XXX=+/- .030	
ITEM NO 386273	SHAPE DESC		
RAW_MATL	HRS 0.000	DESCRIPTION	SHELF ASM.- DRIVERSIDE FORD TRANSIT SHELF OPTION "46-46" 130"WB MED ROOF
DRAWN BY LRE	DATE Dec-03-15		
APPROVED BY	DATE		
SUPERSEDES	SUPERSEDED BY	SCALE 0.200	DWG NAME P15C0669 Sheet 2 of 4

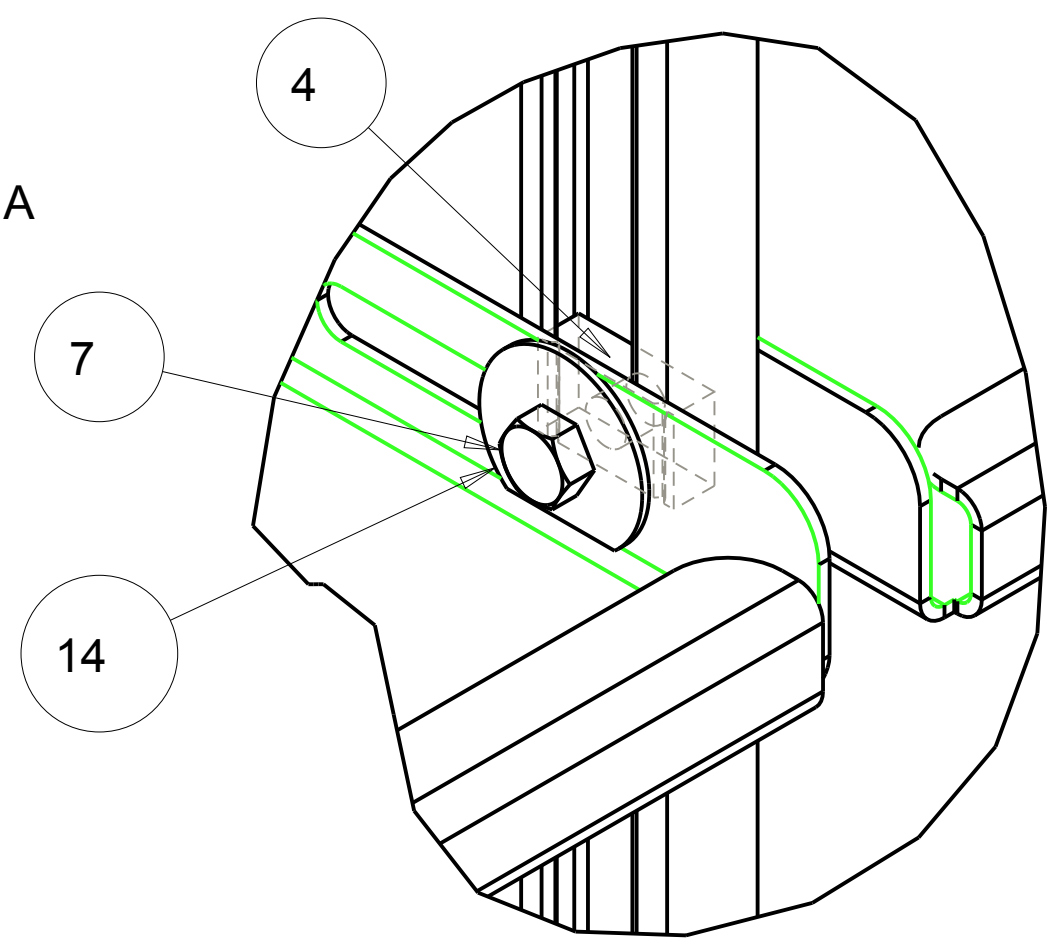
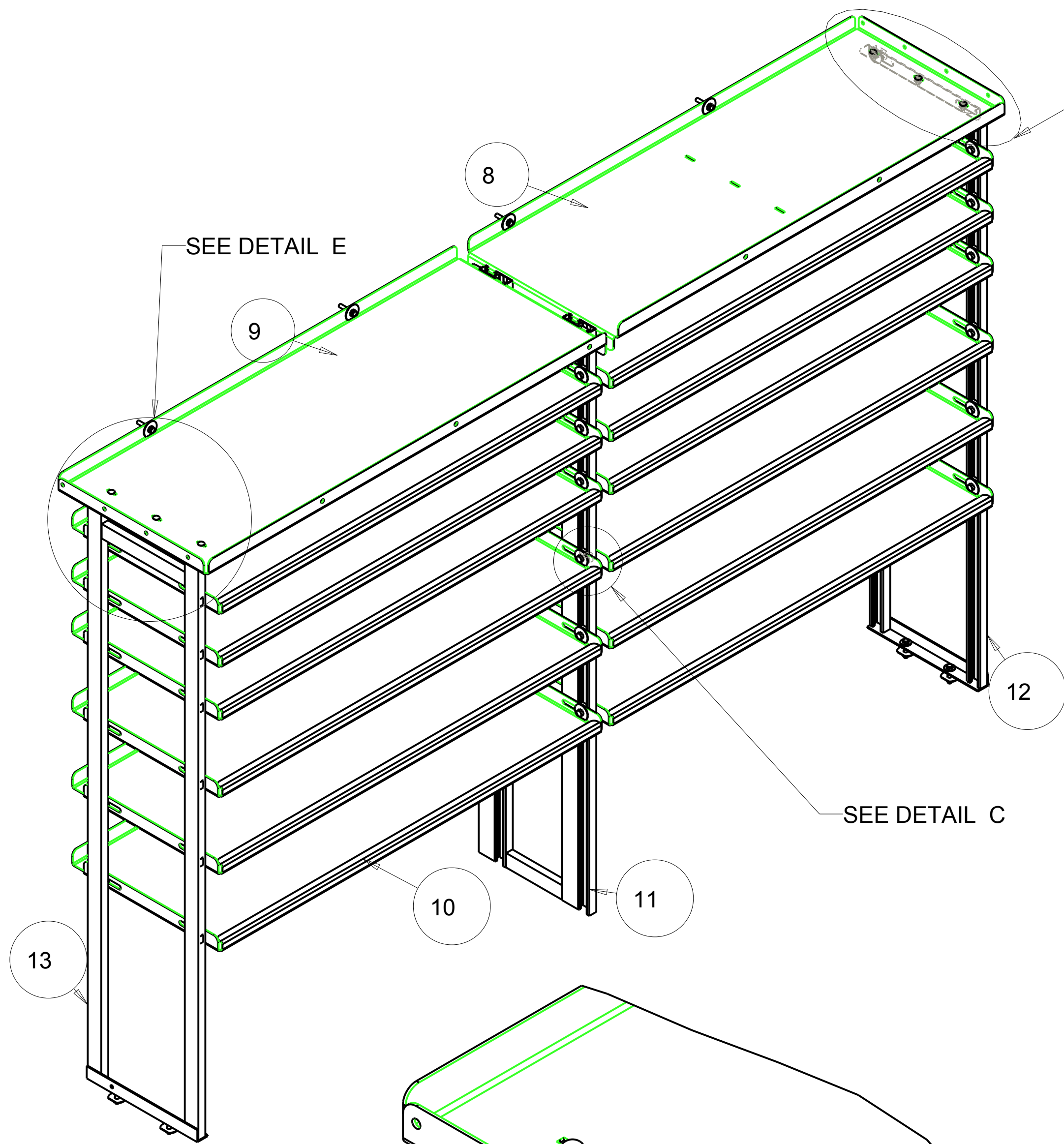

TYP. SHELF HARDWARE
DETAIL C
SCALE 0.800

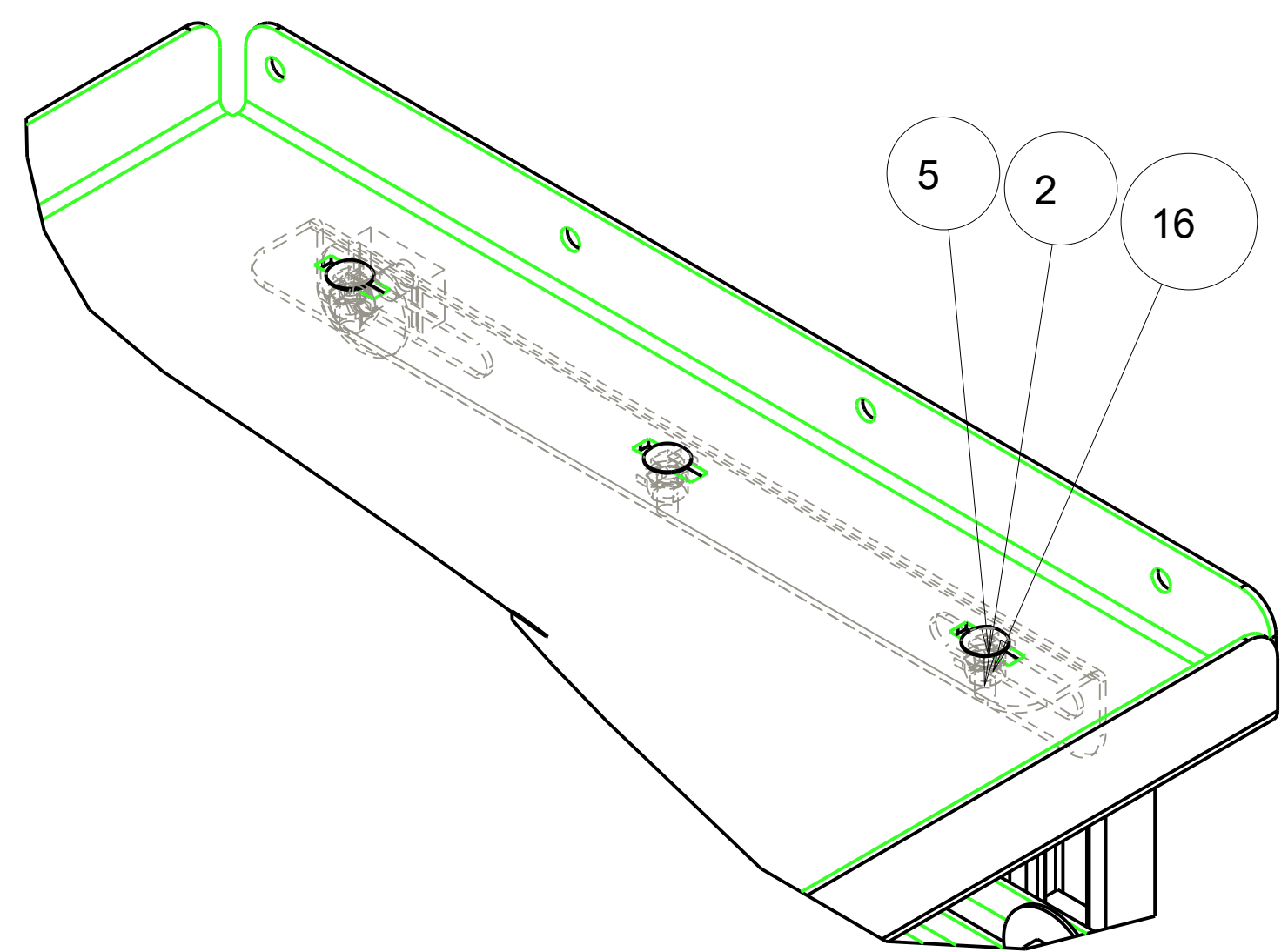

DETAIL A
SCALE 0.500

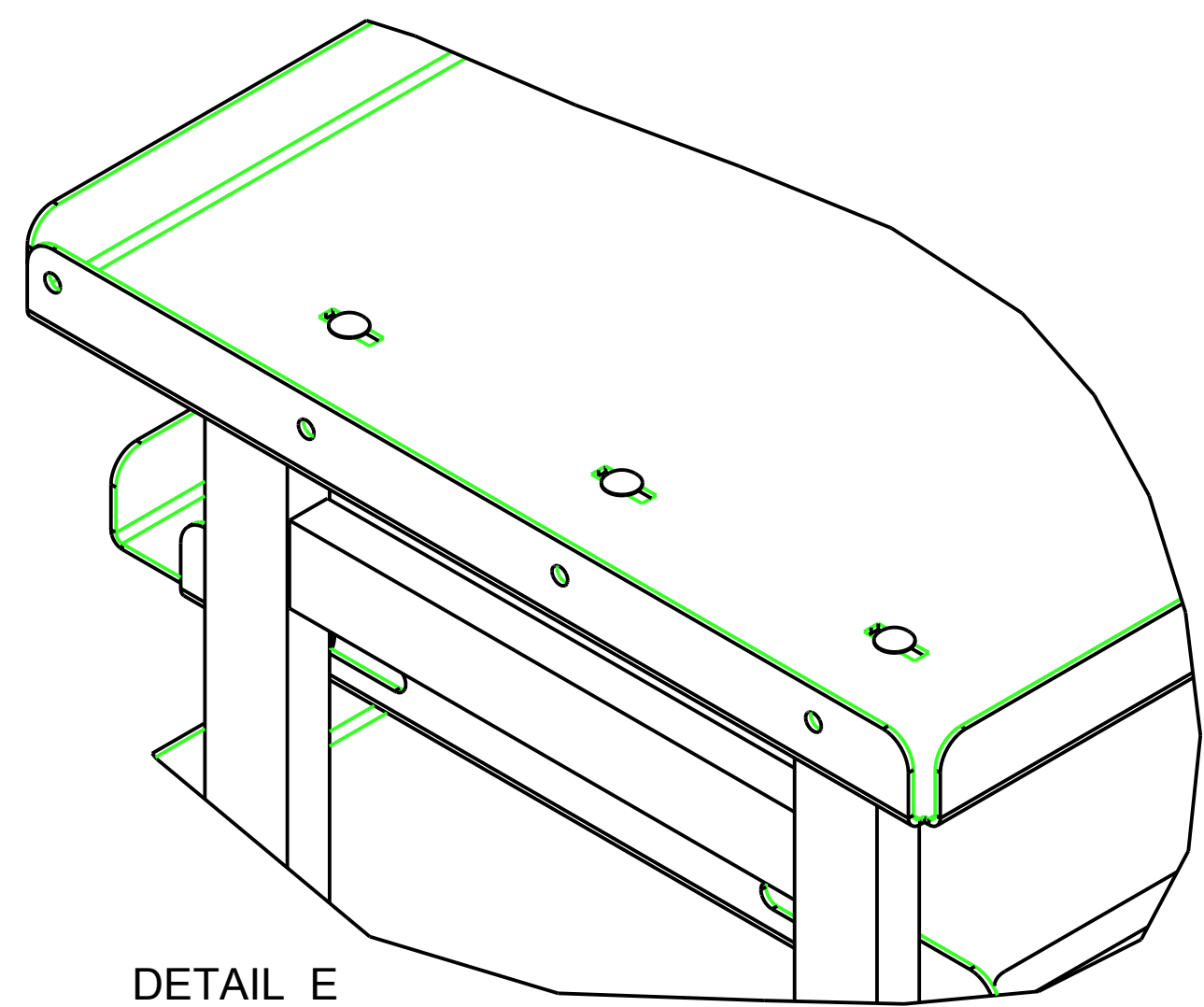

DETAIL E
SCALE 0.400

CNUMBER	WEIGHT	TOLERANCE UNLESS OTHERWISE SPECIFIED
TRANSIT	167.522	
ROUTING	MATL CODE	
FINAL	ZA	.XX=+/- .060 .XXX=+/- .030
ITEM NO	SHAPE DESC	
386273		
RAW_MATL	HRS	
	0.000	
DRAWN BY	DATE	DESCRIPTION
LRE	Dec-03-15	SHELF ASM.- DRIVERSIDE FORD TRANSIT SHELF OPTION "46-46" 130"WB MED ROOF
APPROVED BY	DATE	
SUPERSEDES	SUPERSEDED BY	SCALE
		0.125

VT Hackney *Hackney*
 A company of VT Systems 
 252-946-6521
 vtackney.com hackney.com kidron.com vtvisioncomms.com **VisionComms**

ATTACHMENT DETAILS

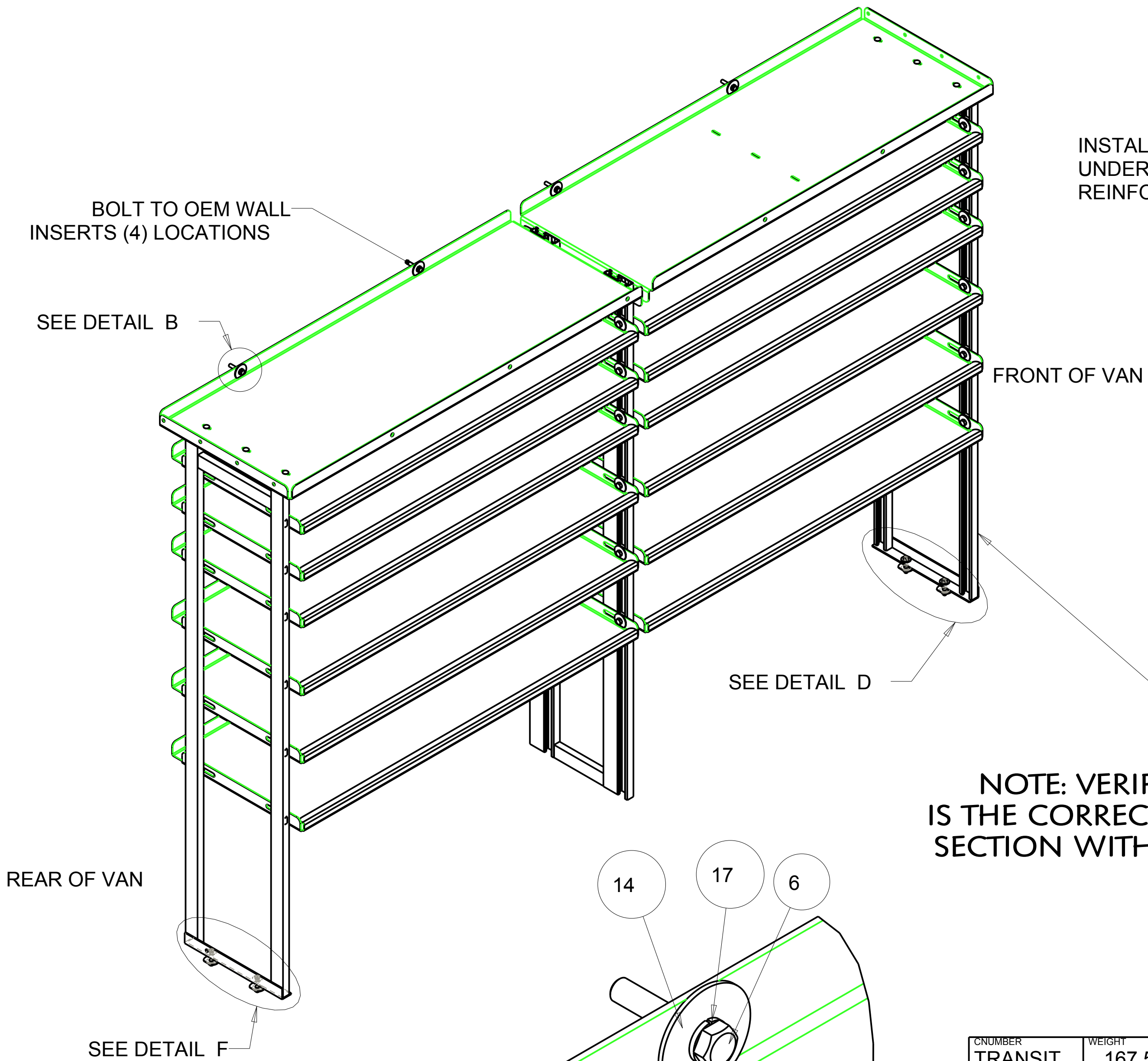

INSTALL FLAT BAR UNDER FLOOR AS REINFORCEMENT

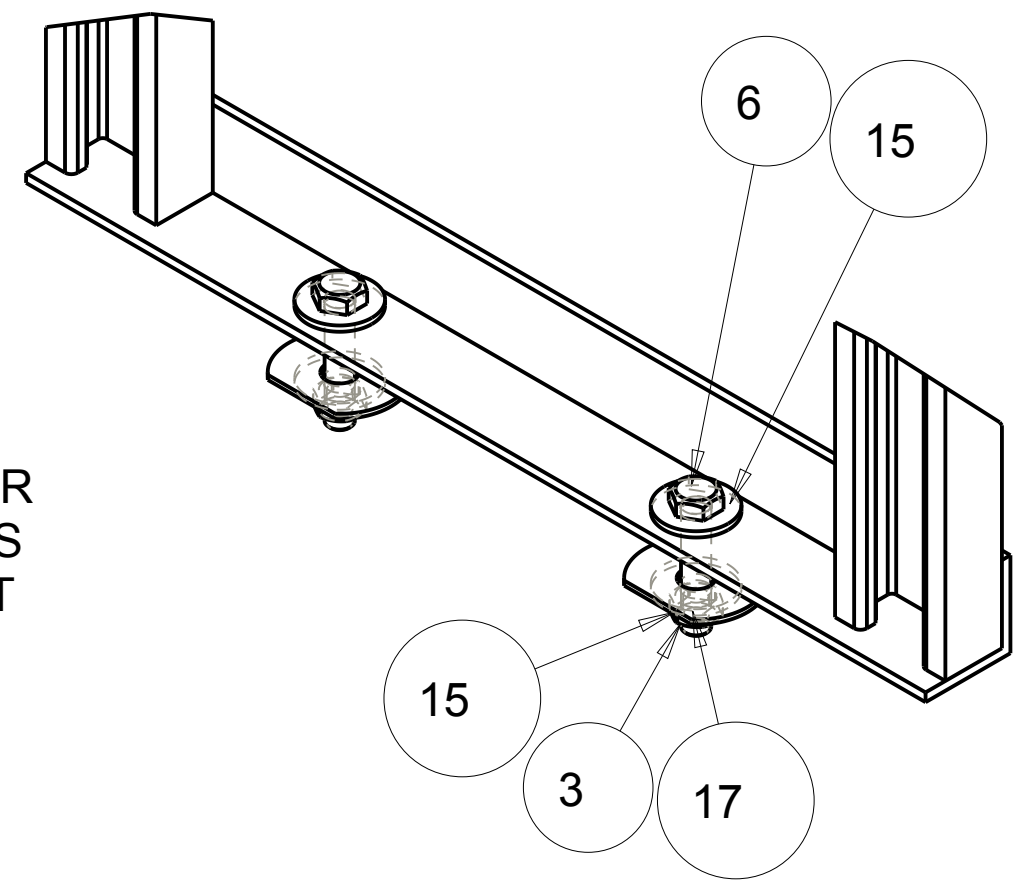

DETAIL D
SCALE 0.500
TYPICAL BOLT
THRU FLOOR
AT FRONT

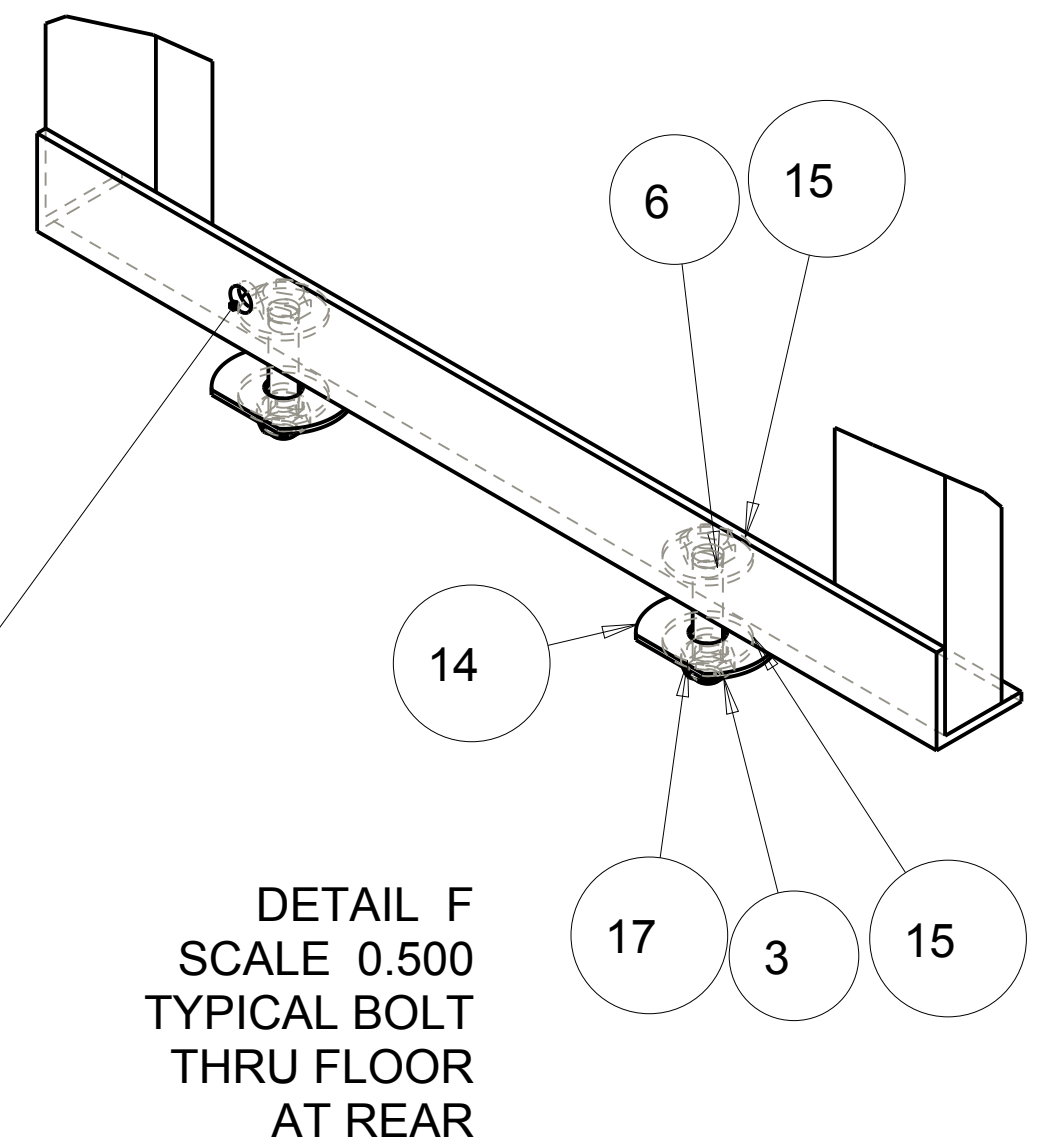

DETAIL F
SCALE 0.500
TYPICAL BOLT
THRU FLOOR
AT REAR

NOTE: VERIFY THIS IS THE CORRECT REAR SECTION WITH HOLE

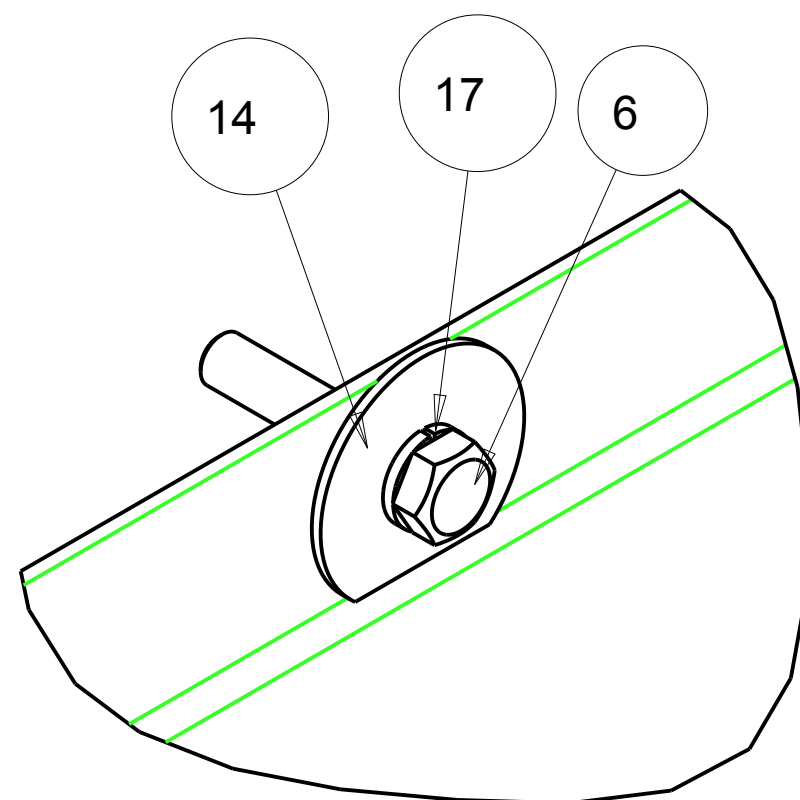

DETAIL B
SCALE 1.000

NUMBER	WEIGHT	TOLERANCE UNLESS OTHERWISE SPECIFIED
TRANSIT	167.522	
ROUTING	MATL CODE	
FINAL	ZA	.XX=+/-_.060 .XXX=+/-_.030
ITEM NO	SHAPE DESC	
386273		
RAW_MATL	HRS	
	0.000	
DRAWN BY	DATE	DESCRIPTION
LRE	Dec-03-15	vthackney.com hackney.com kidron.com vtvisioncomms.com
APPROVED BY	DATE	SHELF ASM.- DRIVERSIDE FORD TRANSIT SHELF OPTION "46-46" 130"WB MED ROOF
SUPERSEDES	SUPERSEDED BY	SCALE
		0.125
		DWG NAME
		P15C0669 Sheet 4 of 4



252-946-6521
vthackney.com hackney.com kidron.com vtvisioncomms.com VisionComms