

Make: Subaru

Model: 2019+ Ascent

Applications: Rally Light Bar

PACKAGE CONTENTS					TOOLS
QTY		QTY		QTY	
1	Rally Light Bar	6	5/16" Flat Washer	2	1/4" Lock Washer
2	Upper Bracket	2	3/8"-16 x 2.5" Hex Bolt	2	1/4"-20 Hex Nut
1	Lower Brace	6	3/8" Flat Washer		
2	3/8" Bolt Plate	2	3/8" Lock Washer		
2	1/2" Flat Washer	2	3/8" Hex Nut		
4	5/16" Lock Washer	2	1/4"-20 x 3/4" Hex Bolt		
4	5/16"-18 x 1" Hex Bolt	4	1/4" Flat Washer		

Flat Head Screwdriver
Ratchet (3/8" & 1/2" Drive)
9/16", 1/2", 7/16" Socket/Wrench
19mm, 17mm, 12mm Socket
Cutting Tool (Blade/Mini Reciprocating Saw)

INSTALLATION INSTRUCTIONS

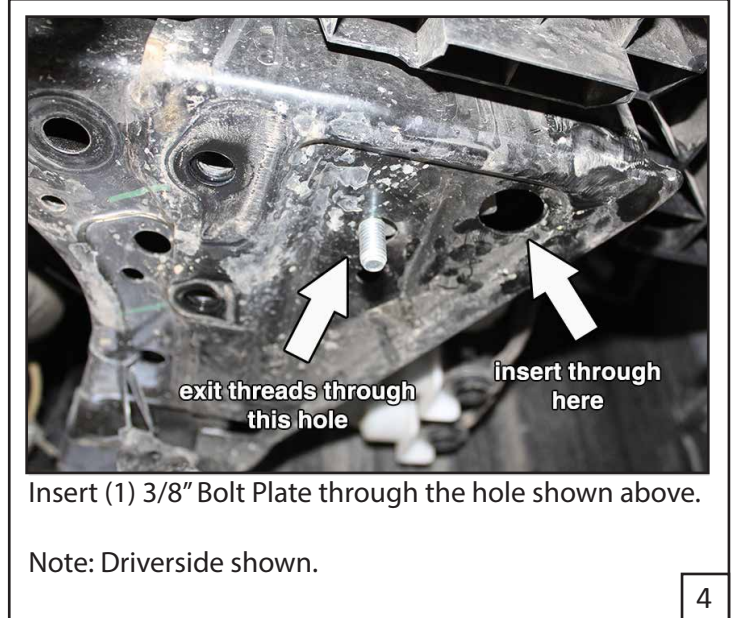
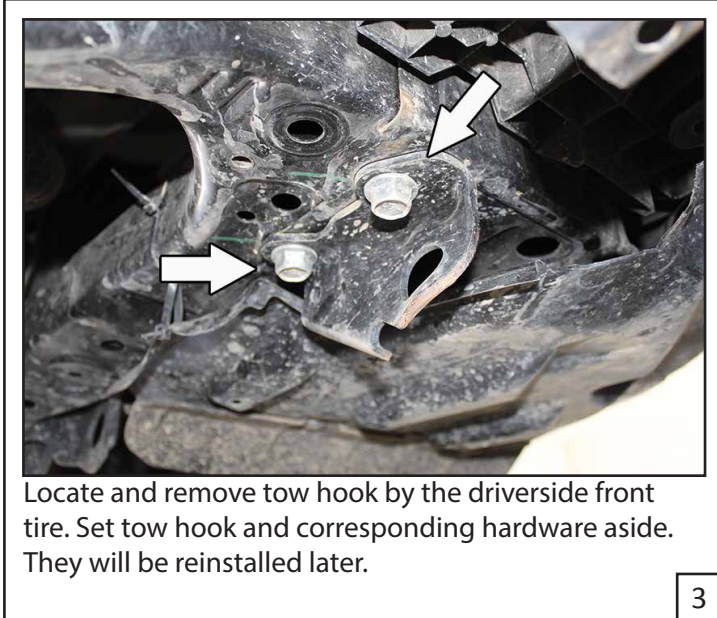
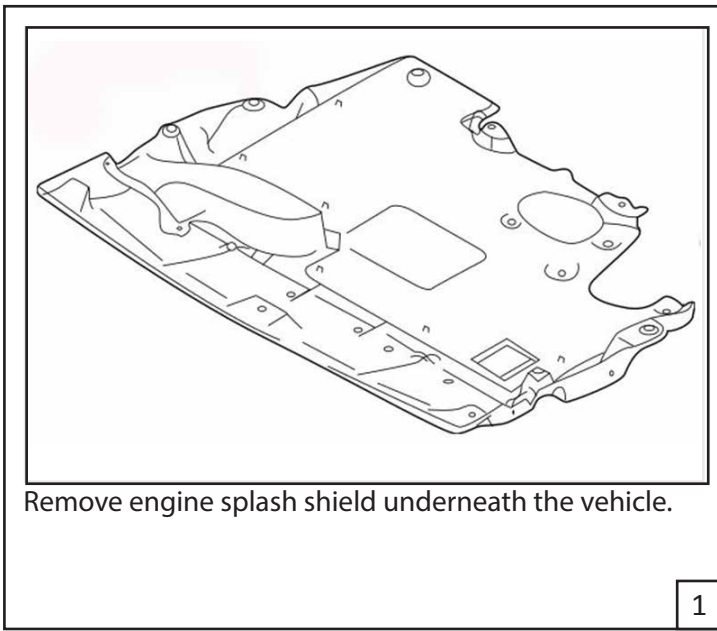

DISCLAIMER FOR RALLY INNOVATIONS PRODUCTS: Buyers assume all risk and liability whatsoever for the installation and the use of Rally Innovations products. Rally Innovations products are sold as decorative accessories and should not be relied upon as protection for the vehicle or occupants in the event of a collision or roll over. Vehicles equipped with a supplemental restraint system (air bag) deployed by impact should not be modified by any aftermarket Light Bar or Skid Guard without first consulting the vehicle manufacturer. Rally Innovations, a subsidiary of Pentech Automotive assumes no liability for injury, loss, incidental or consequential damages in the event of a collision or roll over.



Repeat on the passenger side.

5



Remove the factory 19mm flange head bolt from the hole shown above.

6



Install the driverside Lower Bracket with a 3/8" and 1/2" washer between the chassis and the bracket. Place them above the holes shown. Be careful as they may slide off during install.

7

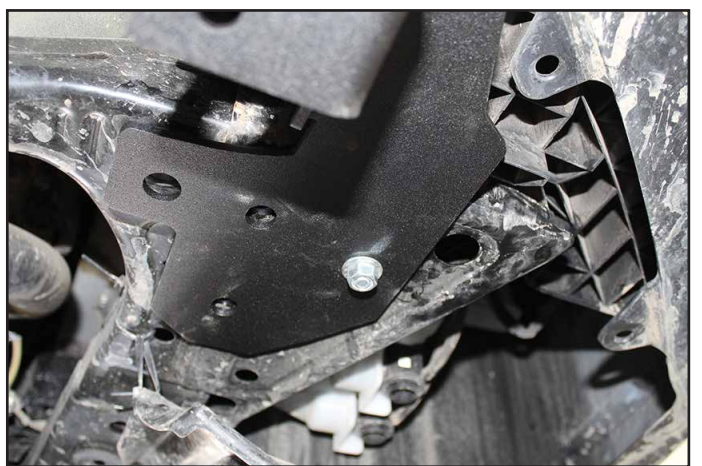

Thread a 3/8" washer and lock nut onto the threads on the bolt plate. Loosely fasten for now.

8

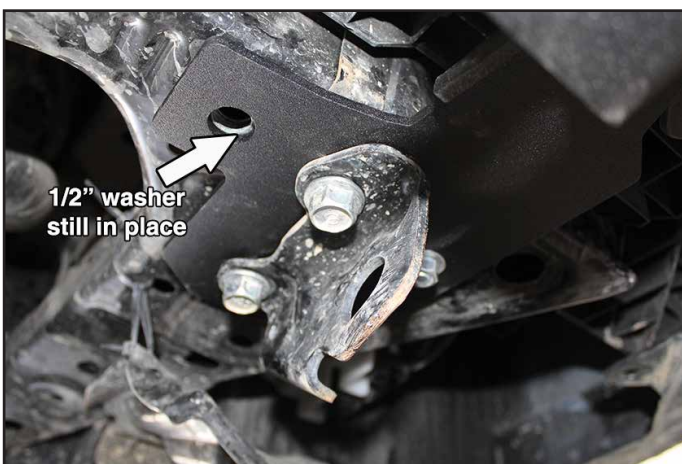

Reinstall the tow hook with the factory bolts. Loosely fasten for now.

9

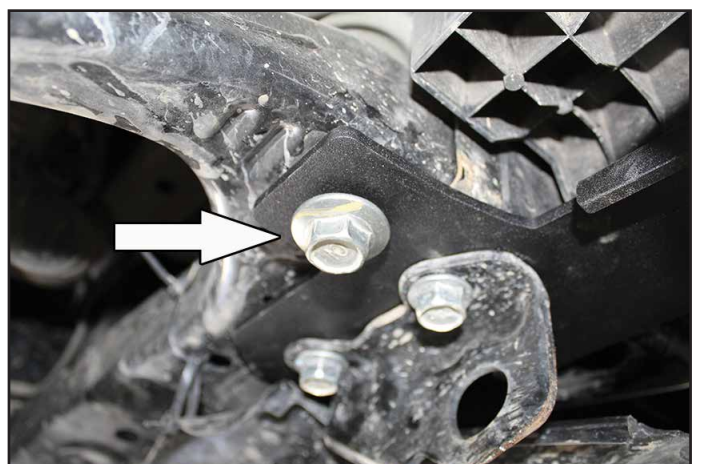

Reinstall the 19mm Flange Head Bolt removed in an earlier step. Before threading in this bolt ensure that the 1/2" washer is still aligned with the hole and in place between the bracket and the chassis. You can see the washer in place in previous image.

10

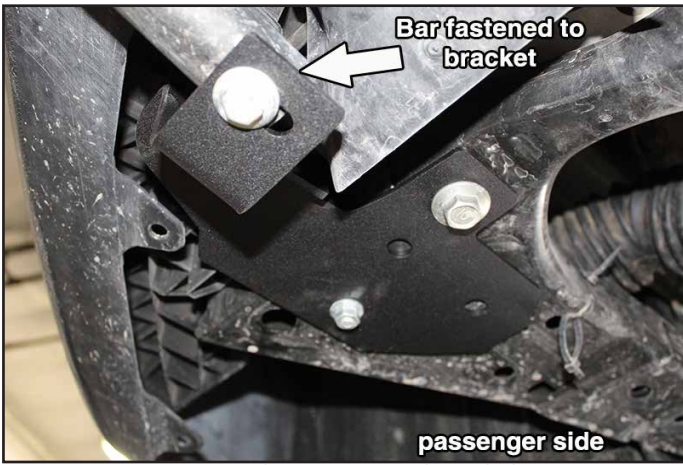

Bar fastened to bracket

passenger side

Repeat previous steps on the passenger side (with the exception of the tow hook; pass side does not have one). Then, fasten the bar loosely onto the lower brackets using (1) 3/8"-16x2.5" Hex Bolt, (2) 3/8" Flat Washers, (1) 3/8" Lock Washer, and (1) 3/8" Hex Nut, per side.

11

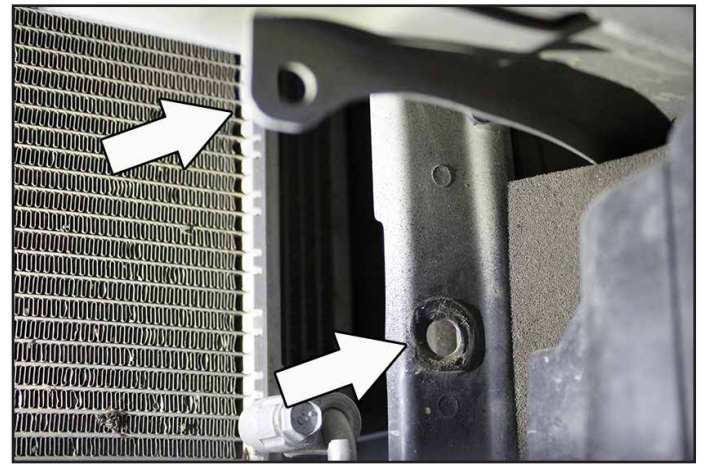

Locate these two mounting holes on the driverside behind the lower front bumper grille.

12



Locate driverside Upper Bracket.

Note: Passenger side Upper Bracket is the opposite orientation of this bracket.

13

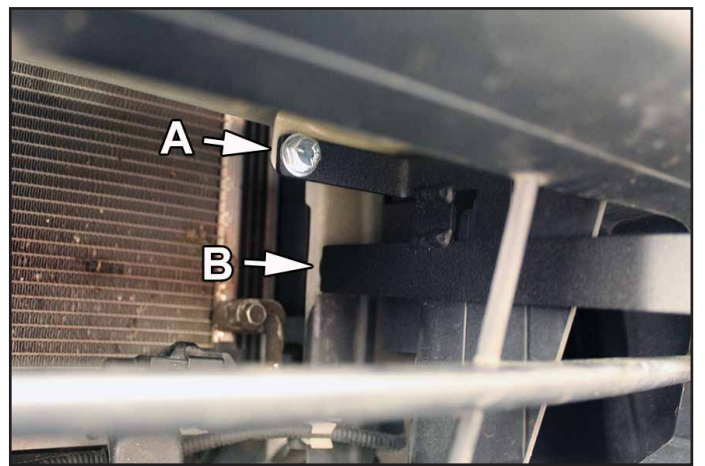

Insert bracket through the lower grille and fasten using (1) 1/4" Hex Bolt, (2) 1/4" Flat Washers, (1) 1/4" Lock Washer, (1) 1/4"-20 Hex Nut on the upper tab (A), then (1) 5/16" Hex Bolt, (2) 5/16" Flat Washers, (1) 5/16" Lock Washer, (1) 5/16" Hex Nut on the bottom tab (B). Loosely fasten for now.

14



Fasten the Upper Bracket to the light bar using (1) 5/16"-18x1" Hex Bolt, (1) 5/16" Lock Washer, and (1) 5/16" Flat Washer. Repeat previous steps to install Upper Bracket on the passenger side. Tighten all fasteners down.

15



bottom view

Hold up the foglight splash shield to its original location and mark which portion needs to be trimmed to clear the Lower Brackets. Repeat on the other foglight splash shield.

16

DISCLAIMER FOR RALLY INNOVATIONS PRODUCTS: Buyers assume all risk and liability whatsoever for the installation and the use of Rally Innovations products. Rally Innovations products are sold as decorative accessories and should not be relied upon as protection for the vehicle or occupants in the event of a collision or roll over. Vehicles equipped with a supplemental restraint system (air bag) deployed by impact should not be modified by any aftermarket Light Bar or Skid Guard without first consulting the vehicle manufacturer. Rally Innovations, a subsidiary of Pentech Automotive assumes no liability for injury, loss, incidental or consequential damages in the event of a collision or roll over.

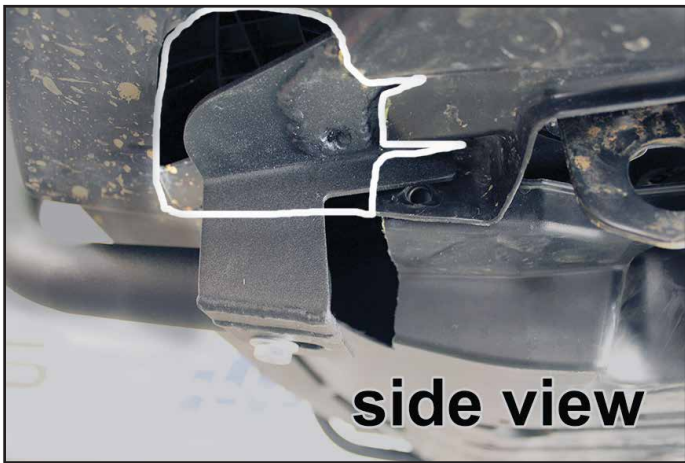

side view

Side view of the foglight splash shield trimmed.

17



Trim the engine splash shield to clear the Lower Brackets.

18

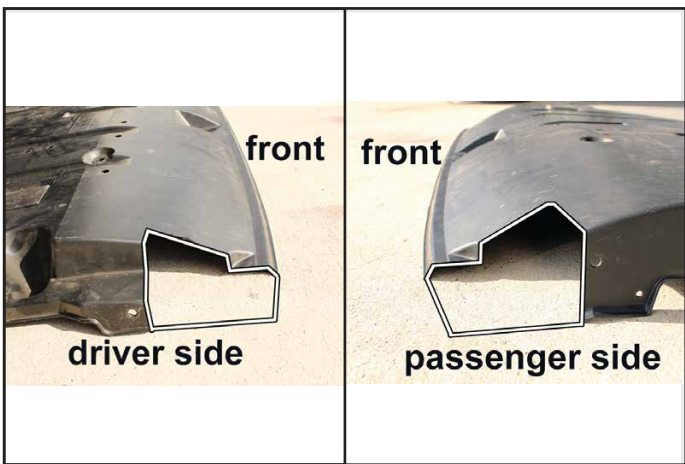

Side view of the cuts made on the engine splash shield.

19



Double-check all fasteners are tightened and reinstall engine splash shield.

20



Completed assembly.

21

DISCLAIMER FOR RALLY INNOVATIONS PRODUCTS: Buyers assume all risk and liability whatsoever for the installation and the use of Rally Innovations products. Rally Innovations products are sold as decorative accessories and should not be relied upon as protection for the vehicle or occupants in the event of a collision or roll over. Vehicles equipped with a supplemental restraint system (air bag) deployed by impact should not be modified by any aftermarket Light Bar or Skid Guard without first consulting the vehicle manufacturer. Rally Innovations, a subsidiary of Pentech Automotive assumes no liability for injury, loss, incidental or consequential damages in the event of a collision or roll over.