

Make: Subaru

Model: 2015+ WRX STI

Applications: Side Splitter

PACKAGE CONTENTS				TOOLS
QTY		QTY		Flat Head Screwdriver 7/16" Socket and Wrench 1/2" Socket and Wrench 3/8" Drill Bit
2	Side Splitters	2	1/4" -20 x .75" Hex Bolt	
10	5/16"-18 x 1" Buttonhead Screw	4	1/4" Washer	
10	5/16" Flat Washer	2	1/4" Lock Washer	
10	5/16" Lock Washer	2	1/4" Nut	
10	5/16" Nut			

INSTALLATION INSTRUCTIONS

Figure 1

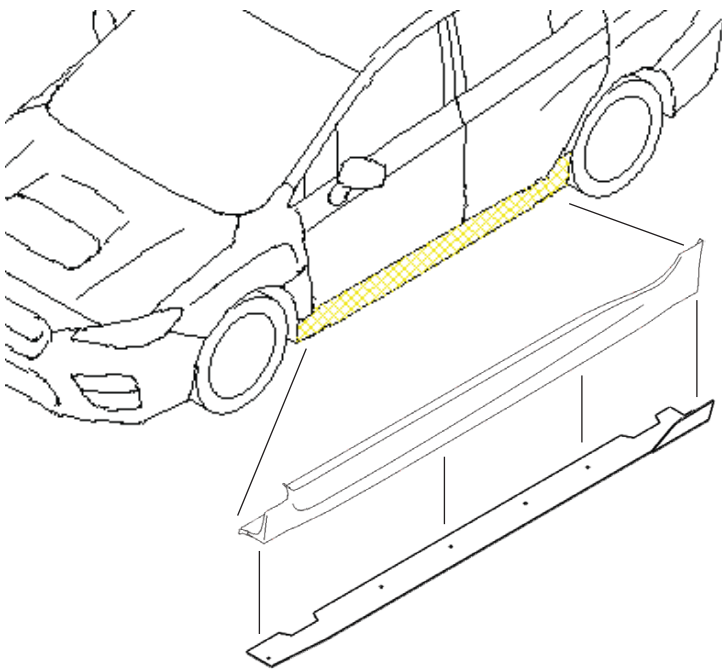
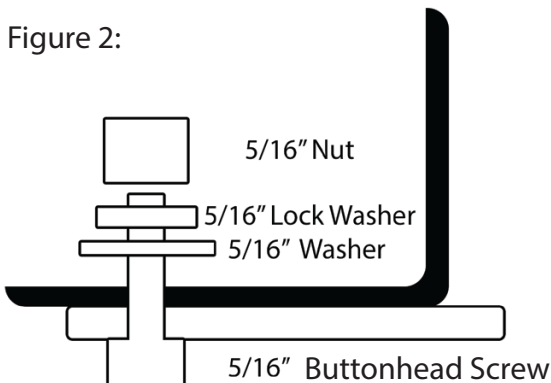

Figure 2:



- 1) Securely lift the vehicle to gain access to the bottom of the side skirt.
- 2) Remove the plastic clips on the bottom of the side skirt so that the side skirt can be pulled down.
- 3) Line up the front and rear edges of the Splitter to the side skirt. Measure roughly 1.5" from the inner edge of the side skirt.
- 4) Align the splitter and drill the rearmost 3/8" hole and attach the supplied hardware as shown in Figure 2.
- 5) Drill the next 3/8" hole and attach the supplied hardware. Make sure the side splitter is flat against the skirt before drilling.
- 6) Drill and install the remaining hardware so the side splitter is firm on the skirt. Install the 1/4" hardware onto the foremost hole.
- 7) Tighten all hardware and reinstall plastic clips onto the side skirts.

Optional:

Remove side skirts for easier installation.

Note:

If a STI side skirt was previously installed, line up the forward hole on the skirt with the forward hole on the Splitter.

MOUNTING HOLES

