

Make: Subaru

Model: 2013-2015 Subaru Crosstrek XV

Application: Light Conversion

PACKAGE CONTENTS				TOOLS	
QTY		QTY		QTY	
2	Light Conversion Bracket				7/16" Socket/Wrench 10mm Socket/Wrench 5/32" Hex Key Panel Removal Tool Wire Crimper

INSTALLATION INSTRUCTIONS

Remove the fog light splash guard to gain access to the fog light area by removing all fasteners with a panel removal tool.

1

Unplug the factory fog light and remove the 10mm-thread screw fastening the light to the bumper (retain for use later).

2

Use lower mounting hole for Squadron lights

Assemble the fog light into the mounting bracket like shown.

3

Align pin into the upper hole

Install the new fog light assembly into the factory location in the reverse order of removal.

4

DISCLAIMER FOR RALLY INNOVATIONS PRODUCTS: Buyers assume all risk and liability whatsoever for the installation and the use of Rally Innovations products. Rally Innovations products are sold as decorative accessories and should not be relied upon as protection for the vehicle or occupants in the event of a collision or roll over. Vehicles equipped with a supplemental restraint system (air bag) deployed by impact should not be modified by any aftermarket Light Bar or Skid Guard without first consulting the vehicle manufacturer. Rally Innovations, a subsidiary of Pentech Automotive assumes no liability for injury, loss, incidental or consequential damages in the event of a collision or roll over.



Repeat steps on the other side.

5

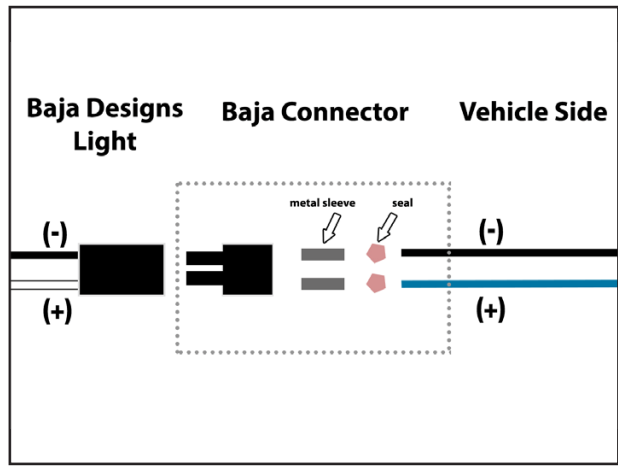

Wiring: Now is a good time to do wiring work to adapt the connection of the new light. We chose to snip the old fog light connector and use the Baja Designs included connector kit to adapt a new plug on the vehicle harness to plug directly into the new light.

6



Completed assembly shown.

7