

Make: Subaru

Model: 1995-1999 Outback

Application: Fog Light Conversion

PACKAGE CONTENTS				TOOLS	
QTY		QTY		Panel Removal Tool Philips Screwdriver 9/16" Socket/Wrench 7/16" Socket/Wrench 3/16" Hex Key	
2	Fog Light Mounting Bracket	4	1/4" Flat Washer		
2	3/8"-16 x 1" Hex Bolt	2	1/4"-20 Kep Nut		
2	1/4"-20 x 3/4" Hex Bolt	4	#8 x 1/2" Philips Screw		
4	3/8" Flat Washer				
2	3/8" Split Lock Washer				
2	3/8" Hex Nut				

INSTALLATION INSTRUCTIONS

Remove factory fog lights from the front bumper by undoing the (2) factory bolts and pull down and out.

1

Unplug the light from the harness by depressing the tab on the back.

2

Take the driver side mounting bracket and place it on the mounting surface in the fog light hole. Note the mounting hole locations and align them. Mark the holes located on the sides of the bracket with a pen.

3

Set aside the bracket and drill out holes to 7/64". Install new fog light onto the mounting bracket. Insert (1) 1/4"-20 Hex Bolt and (1) 1/4" Flat Washer into the small slot on the bracket. Fasten on the back side with (1) 1/4" Flat Washer and (1) 1/4" Kep Nut.

4

DISCLAIMER FOR RALLY INNOVATIONS PRODUCTS: Buyers assume all risk and liability whatsoever for the installation and the use of Rally Innovations products. Rally Innovations products are sold as decorative accessories and should not be relied upon as protection for the vehicle or occupants in the event of a collision or roll over. Vehicles equipped with a supplemental restraint system (air bag) deployed by impact should not be modified by any aftermarket Light Bar or Skid Guard without first consulting the vehicle manufacturer. Rally Innovations, a subsidiary of Pentech Automotive assumes no liability for injury, loss, incidental or consequential damages in the event of a collision or roll over.

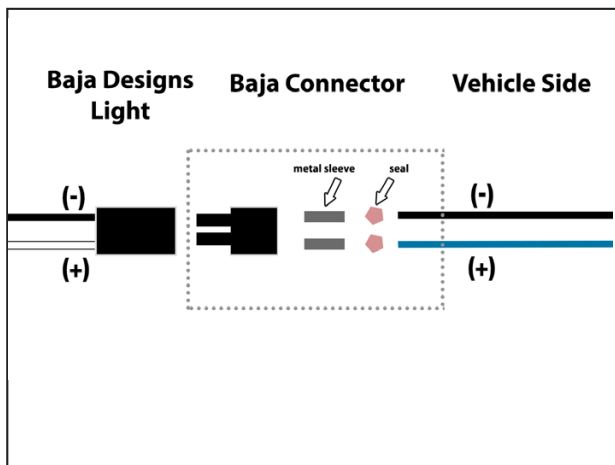

Wiring: Now is a good time to do wiring work to adapt the connection of the new light.

Optional: We chose to snip the old fog light connector and use the Baja Designs included connector kit to adapt a new plug on the vehicle harness to plug directly into the new light.

5



Tighten all the hardware and repeat steps on the opposite side fog light.

Completed assembly shown.

6