



Make: Ford

Model: 2013+ Focus ST
2017+ Focus RS

Applications: Side Splitter

PACKAGE CONTENTS				TOOLS
QTY		QTY		
2	Side Splitters	2	1/4" -20 x .75" Hex Bolt	Flathead Screwdriver 7/16" Socket and Wrench 1/2" Socket and Wrench 3/8" Drill Bit
12	5/16"-18 x 1" Buttonhead	4	1/4" Washer	
12	5/16" Flat Washer	2	1/4" Lock Washer	
12	5/16" Lock Washer	2	1/4" Nut	
12	5/16" Nut			

INSTALLATION INSTRUCTIONS

Figure 1

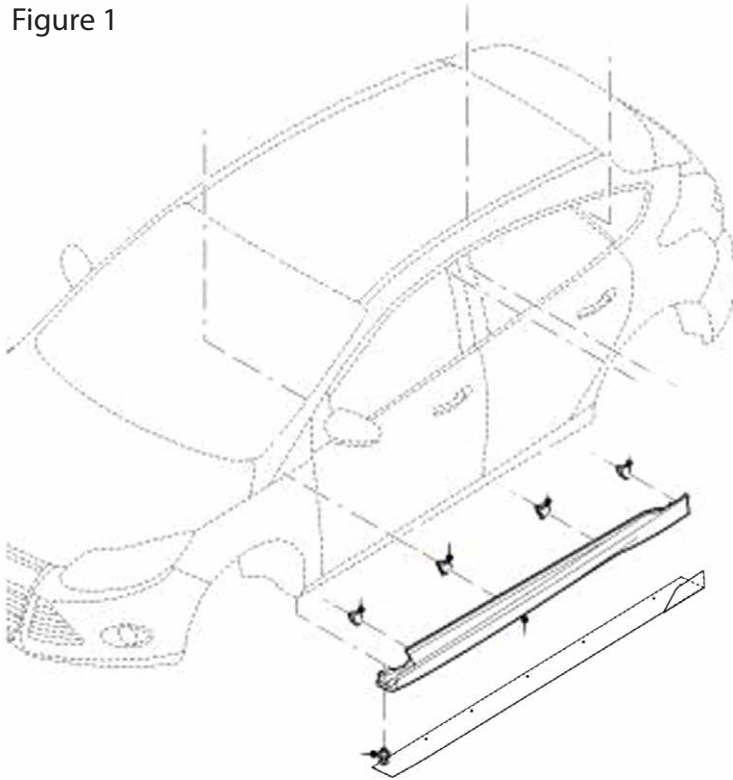

- 1) Securely lift the vehicle to gain access to the bottom of the side skirt.
- 2) Remove the plastic clips on the bottom of the side skirt so that the side skirt can be pulled down.
- 3) Line up the 1/4" hole with the rectangular opening at the front of the side skirt and fasten with 1/4" Hardware.
- 4) Align the splitter and drill the foremost 3/8" hole and attach the supplied hardware as shown in Figure 2.
- 5) Drill the next 3/8" hole and attach the supplied hardware. Make sure the side splitter is flat against the skirt before drilling.
- 6) Drill and install the remaining hardware so the side splitter is firm on the skirt.
- 7) Tighten all hardware and reinstall plastic clips onto the side skirts.

Figure 2:

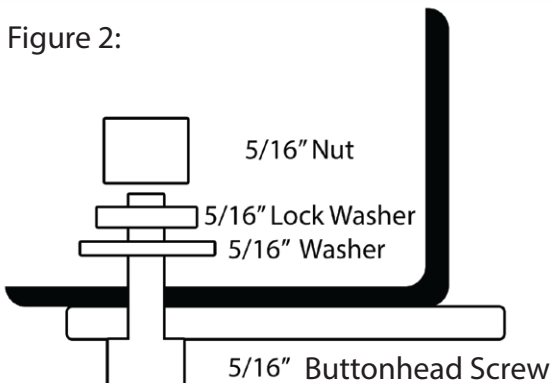

Optional:
Remove side skirts for easier installation.