

The space required to install a sail should be larger than the sail's dimensions in a relaxed state. This allows the sail to be tensioned to fill the space, which minimizes sagging, improves water shed, and reduces any movement in the sail caused by the wind. Tenshon's pulleys create an additional offset of approximately 15" from each attachment point. This guide provides the ideal space requirements in order to have a properly tensioned sail.

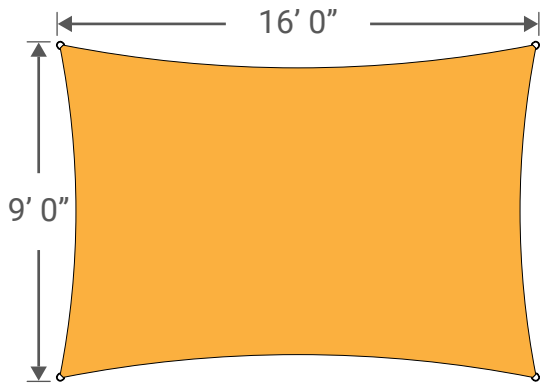

Dimensions of a relaxed sail

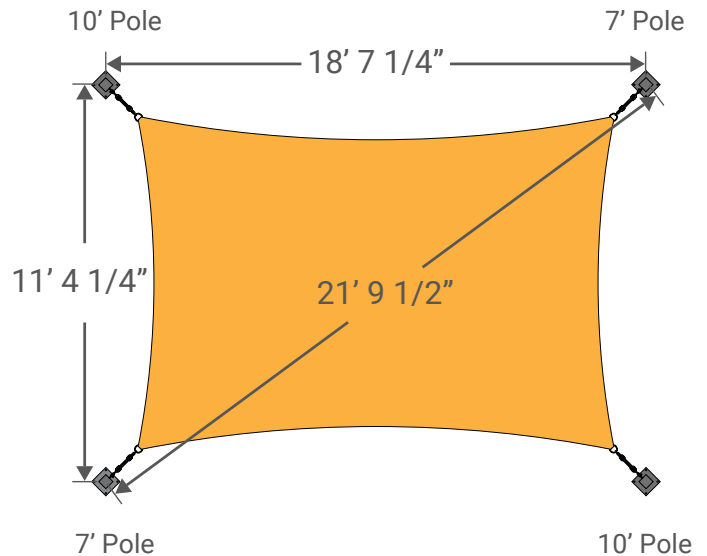

Dimensions from center-to-center of footings for optimal pole placement.

Each pole or attachment point should be placed on a line that bisects the corner angle of the shade sail. This will evenly apply tension to all edges of the shade sail to reduce sagging and bunching at the corners.

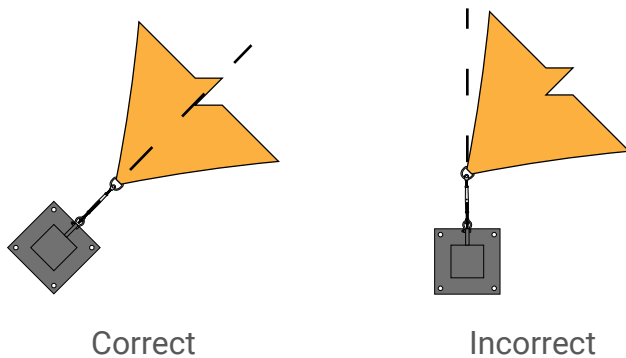

We recommend using a concrete footing with a rebar cage and anchor bolt cluster as each pole's foundation. For specific footing details, please consult a qualified builder or have engineering done by Tenshon®.

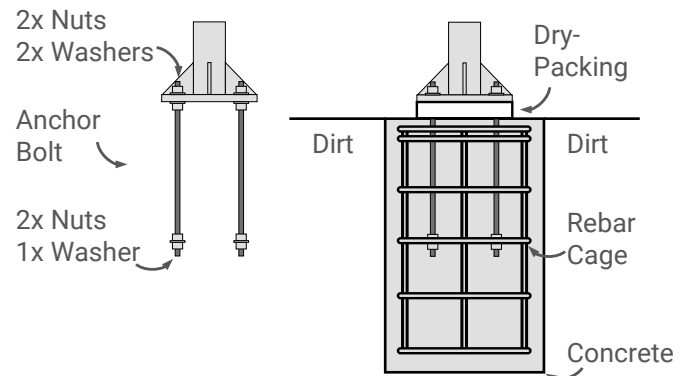

DISCLAIMER: This information is provided as a courtesy to Tenshon® customers and is to be used as general guidelines. These are not to be used as construction documents or build plans. Tenshon® accepts no responsibility for the accuracy of steel sizing, footing details, or any other information contained in this document. If you are unsure about your installation or a structure's capacity to accept the forces associated with a shade sail, please consult a qualified builder or engineer.