

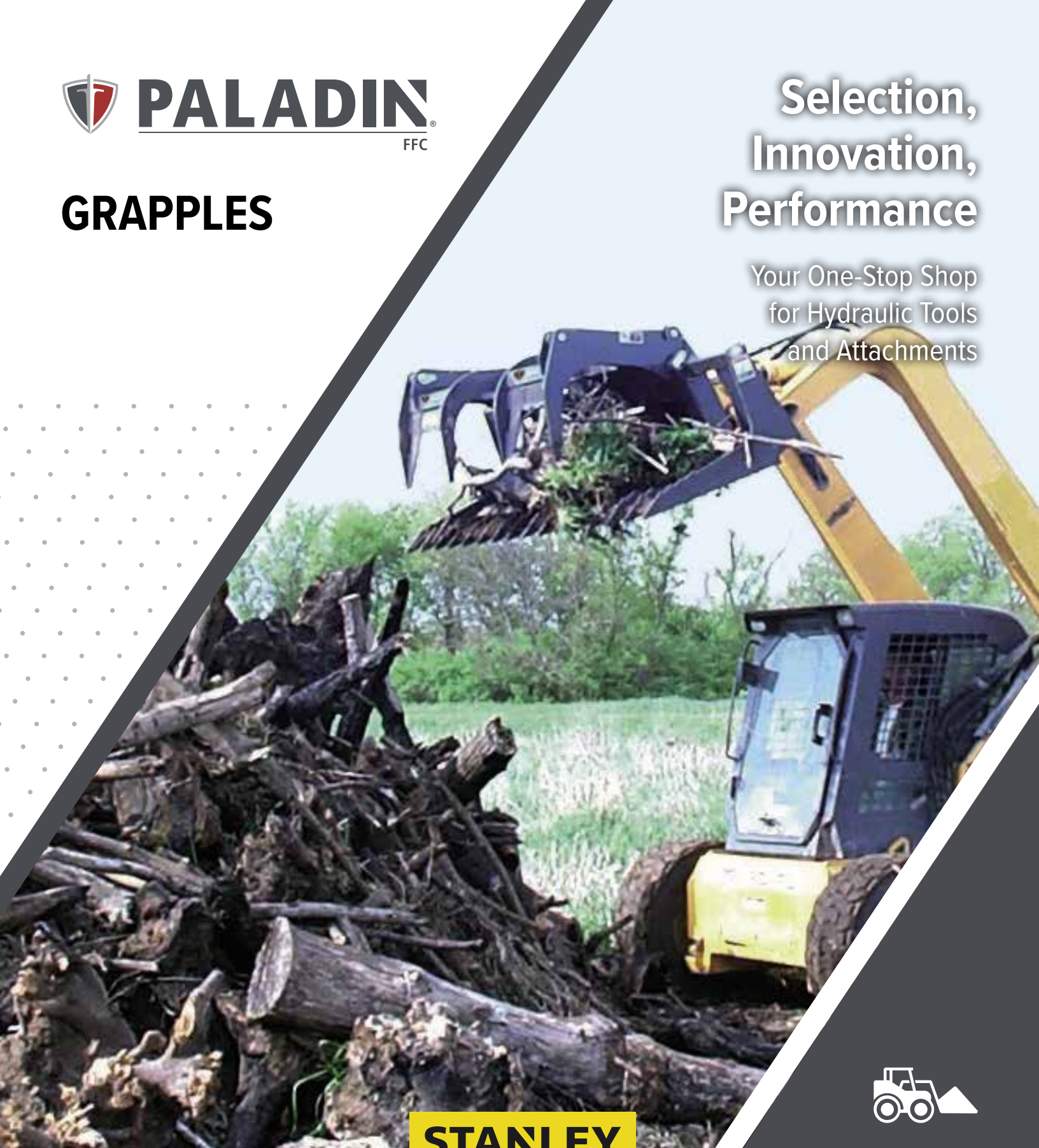

GRAPPLES

Selection, Innovation, Performance

Your One-Stop Shop
for Hydraulic Tools
and Attachments



STANLEY
Infrastructure

INDUSTRIAL TOOLS & ATTACHMENTS

 **PALADIN**  **STANLEY**  **LABOUNTY**  **PENGO**

BRUSH GRAPPLES



- 6" tine spacing
- Standard cylinder guards protect all cylinder components
- 1 1/4" cylinder pivot pins
- 1 1/4" x 24" patented grapple pins greatly reduce torsional force
- 3/8" end plates on Utility Grapple 1/2" end plates on Construction Grapple
- Patented cushioned and sleeved cylinders are 2" x 8" x 1 1/4"
- Standard load check valve
- 100,000 PSI yield strength tine material

SCRAP GRAPPLES



- Standard cylinder guards protect all cylinder components
- Standard load check valve
- 1 1/4" cylinder pivot pins
- 1 1/4" x 24" patented grapple pins reduce torsional force
- Patented cushioned cylinders are 2" x 8" x 1 1/4" on full feature
- Bucket edge drilled for FFC® replaceable edge unless specified
- Optional 3/4" x 8" double beveled edge

SPECIFICATIONS	UTILITY BRUSH GRAPPLE			CONSTRUCTION BRUSH GRAPPLE			
	12260-0022	12266-0022	12272-0022	11372-0022	11378-0022	11384-0022	11390-0022
A. Overall Width	60.75"	66.75"	72.75"	73"	79"	85"	91"
B. Grapple Open	33"	33"	33"	40"	40"	40"	40"
C. Grapple Closed	17.375"	17.375"	17.375"	16.5"	16.5"	16.5"	16.5"
D. Overall Depth	36"	36"	36"	39"	39"	39"	39"
Weight	723 lbs	740 lbs	775 lbs	925 lbs	999 lbs	1054 lbs	1105 lbs
Number of Tines	11	12	14	14	14	16	16

SPECIFICATIONS	UTILITY SCRAP GRAPPLE			CONSTRUCTION SCRAP GRAPPLE		
	12860-0022	12866-0022	12872-0022	11876-0022	11882-0022	11888-0022
A. Overall Width	60.75"	66.75"	72.75"	76"	82"	88"
B. Overall Height - Grapple Open	34"	34"	34"	40"	40"	40"
C. Overall Height - Grapple Closed	19.75"	19.75"	19.75"	20"	20"	20"
D. Overall Depth	36"	36"	36"	38"	38"	38"
Weight	738 lbs	788 lbs	835 lbs	1081 lbs	1133 lbs	1180 lbs
Number of Tines	11	12	14	14	14	16

IMPORTANT: All replacement hydraulic hoses and fittings must have a minimum rated working pressure of 4000 psi.

***NOTE:** When ordering new Grapples you must also order the appropriate hose kit. The new Grapples will not automatically ship with hoses.

Carrier Specifications:	Utility	Construction
lift capacities	<4,000 lbs	<5,000 lbs
operating weight	<6,500 lbs	<9,500 lbs

Hose Kit Part Numbers

60"	80"	88"
MTG1113-0022	MTG1113-0903	MTG1113-9783

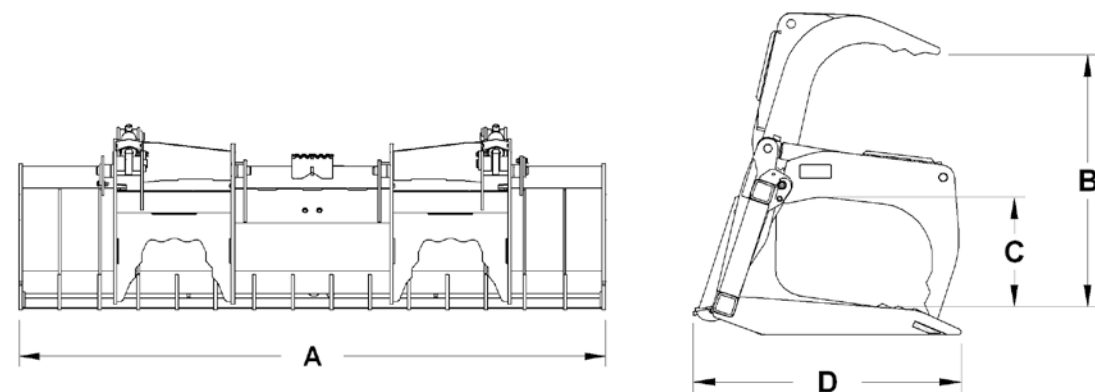

IMPORTANT: All replacement hydraulic hoses and fittings must have a minimum rated working pressure of 4000 psi.

***NOTE:** When ordering new Grapples you must also order the appropriate hose kit. The new Grapples will not automatically ship with hoses.

Carrier Specifications:	Utility	Construction
lift capacities	<4,000 lbs	<5,000 lbs
operating weight	<6,500 lbs	<9,500 lbs

Hose Kit Part Numbers

60"	80"	88"
MTG1113-0022	MTG1113-0903	MTG1113-9783

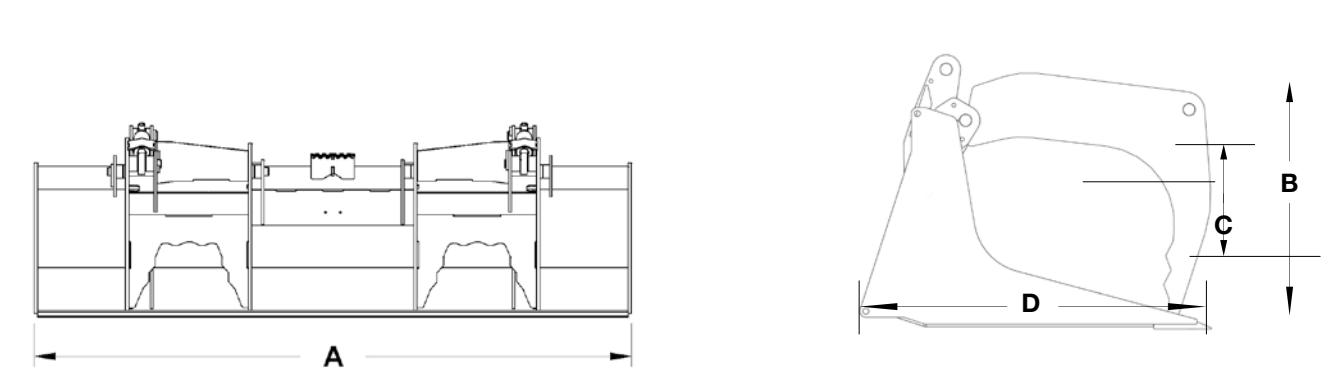

SCRAP GRAPPLES

MODEL 120 SCRAP GRAPPLES

For Skid-Steer Loaders and Compact Tool Carriers

- Optional cylinder guards protect all cylinder components
- 1½" x 8-5/8" heat-treated, greasable pivot pins on full feature
- 1½" x 27-1/8" patented grapple pins reduce torsional force
- 3/8" end plates
- Patented cushioned & sleeved cylinders are 2½" x 8" x 1¾" on full feature
- Bucket edge drilled for FFC® replaceable edge unless specified
- Optional ¾" x 8" double beveled edge

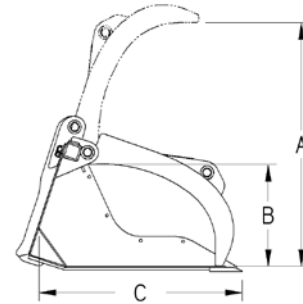

SPECIFICATIONS	UTILITY SCRAP GRAPPLE				CONSTRUCTION SCRAP GRAPPLE			
	LAF5273	LAF5278	LAF5282	LAF5287	LAF5073	LAF5078	LAF5082	LAF5087
A. Width	74"	79"	83"	88"	74"	79"	83"	88"
B. Overall Height - Grapple Open	45.4"	45.4"	45.4"	45.4"	45.4"	45.4"	45.4"	45.4"
C. Overall Height - Grapple Closed	19.1"	19.1"	19.1"	19.1"	19.1"	19.1"	19.1"	19.1"
D. Overall Depth	37.8"	37.8"	37.8"	37.8"	37.8"	37.8"	37.8"	37.8"
Weight	1303 lbs	1514 lbs	1542 lbs	1571 lbs	1266 lbs	1301 lbs	1329 lbs	1364 lbs

IMPORTANT: All replacement hydraulic hoses and fittings must have a minimum rated working pressure of 4000 psi.

***NOTE:** When ordering new Grapples you must also order the appropriate hose kit. The new Grapples will not automatically ship with hoses.

Carrier Specifications:	Utility	Construction
lift capacities	<4,000 lbs	<5,000 lbs
operating weight	<6,500 lbs	<9,500 lbs

OPTIONS	ORDER CODE	WEIGHT
Hardened Pin Kit for Model 120	LAF5003	45
Cylinder/Hose Guard Kit for Model 120	LAF5004	57
End Plate Extension - Full Kit for Model 120	LAF5250	NA

MODEL 130 SCRAP GRAPPLES

For Telehandlers, Wheel Loaders and Backhoe Loaders

- Optional cylinder guards protect all cylinder components
- 1½" x 8-5/8" heat-treated, greasable pivot pins
- 1½" x 27-1/8" patented grapple pins reduce torsional force
- Patented cushioned & sleeved cylinders are 2 ½" x 8" x 1 ¾"
- Bucket edge drilled for FFC replaceable edge unless specified
- Optional ¾" x 8" double beveled edge

Carrier Specifications:	
lift capacities	<9,000 lbs
operating weight	<11,000 lbs

SPECIFICATIONS	LAF5283	LAF5294
A. Width	83"	94"
B. Overall Height Grapple Open	47.4"	47.4"
C. Overall Height Grapple Closed	21.8"	21.5"
D. Overall Depth	37.3"	37.3"
Weight	1665 lbs	1745 lbs

IMPORTANT: All replacement hydraulic hoses and fittings must have a minimum rated working pressure of 4000 psi.

OPTIONS	ORDER CODE	WEIGHT
End Plate Extension - Full Kit for Model 120	LAF5252	50