

SOLIDEAL NON-MARKING TIRES BY CAMSO

COMPLETE RANGE OF HIGH PERFORMING NON-MARKING TIRES



KEY BENEFITS OF SOLIDEAL'S 100% NATURAL RUBBER NON-MARKING TIRES

- Clean running, leaving no tire marks behind or black dust on products
- Increased tire life and overall performance
- Lower rolling resistance and better energy efficiency, which increases battery life and reduces fuel consumption
- Enhanced thermal capabilities to lower heat build-up
- Reduced chunking and cutting thanks to natural rubber compound
- Extra age resistance due to presence of natural antioxidants
- Improved color stability and UV resistance to reduce yellowing
- Ideal for indoor operations and electrically-powered equipment
- Preferred in rental applications because of their versatility and compliance with industry requirements



HIGH-PERFORMING AND INDUSTRY-LEADING

As companies upgrade their facilities, improve floor conditions, and manage dirt-sensitive technology and goods, they don't want to see tire marks or black rubber dust on the floor or on their products. No matter what the industry, from Food & Beverage, to Pulp and Paper as well as Pharmaceutical, Solideal non-marking tires by Camso ensure a clean working environment, without sacrificing performance.

DID YOU KNOW?

Industries with the highest requirements of hygiene and cleanliness all rely on non-marking tires, and in most of the applications, on grey-colored ones.

0.1% of carbon black is added to Camso's natural rubber mix to obtain a stabilized color without compromising non-marking properties, giving Solideal's non-marking tires their color.

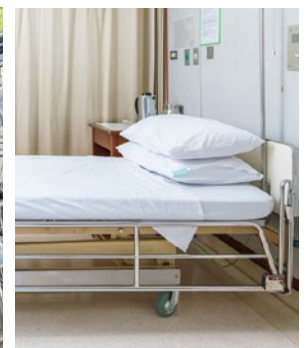

RESILIENT TIRES

SOLIDEAL RES XTREME NMA5 BY CAMSO



ANTI-STATIC

Engineered to prevent static electricity build-up in high intensity applications



WIDE TREAD PROFILE

- Increases lateral load stability
- Safer in high-lift and cornering situations

WEAR INDICATOR

- Ensures maximum utilization

PATENTED ANTI-STATIC TECHNOLOGY

- Prevents static electricity build-up to eliminate the risk of safety issues, fires and facility damages

CONTINUOUS CENTER LUG

- Reduces vibrations which lowers heat build-up and increases life
- Increases operator comfort and slows wear on driveline components

SOLIDEAL XTREME NM BY CAMSO

Optimal non-marking resilient solution for high intensity applications



WIDE TREAD PROFILE

- Increases lateral load stability
- Safer in high-lift and cornering situations

WEAR INDICATOR

- Ensures maximum utilization

NON-MARKING NATURAL RUBBER COMPOUND

- Prevents visible marks on the floor, ensuring a clean working environment
- Reduces chunking and cutting

CONTINUOUS CENTER LUG

- Reduces vibrations which lowers heat build-up and increases life
- Increases operator comfort and slows wear on driveline components

SOLIDEAL MAGNUM NM BY CAMSO

Optimal non-marking resilient solution for medium intensity applications



WIDE PROFILE AND FLAT FOOTPRINT

- Increases stability and grip

RUBBER COMPOUND

- Prevents visible marks on the floor, ensuring a clean working environment
- Reduces chunking and cutting

LARGE TREAD BLOCKS AND DEEP LUGS

- Improves tire life and provides better traction

60J LINE

- Ensures maximum tire utilization

ESTABLISHED TREAD PATTERN DESIGN

- Delivers proven reliability for over 25 years

SOLIDEAL RIB NM BY CAMSO

Ultimate non-marking
tire for low vibration

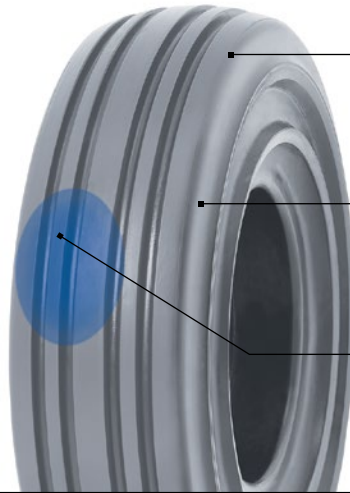

LOW ROLLING RESISTANCE

- Increases battery life and reduces fuel consumption

NON-MARKING NATURAL RUBBER COMPOUND

- Prevents visible marks on the floor, ensuring a clean working environment
- Reduces chunking and cutting

CIRCUMFERENTIAL RIBS

- Offers high cornering capability and low vibration
- Prevents snaking and cupping

PRESS-ON

SOLIDEAL 550 NM BY CAMSO

Non-marking with maximum
life for medium intensity
applications



WIDE PROFILE AND FLAT FOOTPRINT

- Increases stability and grip

UNIQUE TWO-STAGE CONSTRUCTION

- Inner thermal-layer reduces heat build-up for enhanced tire life

LOW ROLLING RESISTANCE COMPOUND

- Increases energy efficiency and thermal performance

NON-MARKING NATURAL RUBBER COMPOUND

- Prevents visible marks on the floor, ensuring a clean working environment
- Reduces chunking and cutting



SOLIDEAL 555 NM BY CAMSO

Non-marking with maximum
life for medium intensity
applications

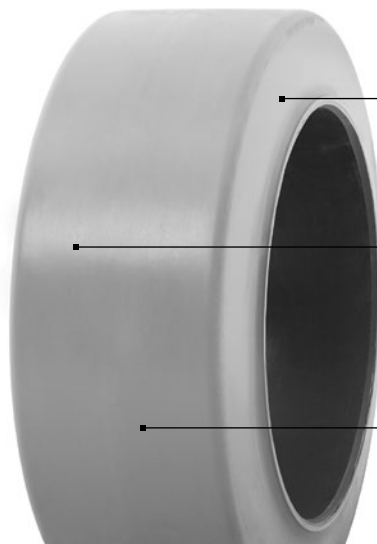

LOW ROLLING RESISTANCE COMPOUND

- Increases energy efficiency and thermal performance

NON-MARKING NATURAL RUBBER COMPOUND

- Prevents visible marks on the floor, ensuring a clean working environment
- Reduces chunking and cutting

UNIQUE TWO-STAGE CONSTRUCTION

- Inner thermal-layer reduces heat build-up for enhanced tire life



SOLIDEAL PON 775 NMAS BY CAMSO



Engineered to prevent static shocks in high intensity applications



WIDE PROFILE AND FLAT FOOTPRINT

- Reduces ground pressure to minimize heat built-up

PATENTED ANTI-STATIC TECHNOLOGY

- Prevents static electricity build-up to eliminate the risk of safety issues and truck damage

UNIQUELY ENGINEERED SIDEWALL

- Reduces heat build-up caused by stresses in the tread shoulders

THERMALLY EFFICIENT CONSTRUCTION

- Provides a cooler running tire and the best in class energy efficiency

ABRASION-RESISTANT TREAD COMPOUND

- Increases tire life

INDUSTRIAL PNEUMATIC

SOLIDEAL ED PLUS NM BY CAMSO

Durable, performing and comfortable non-marking tire



DEEP TREAD LUG

- Improves tire life and provides better traction

THICK SIDEWALL

- Protects against side impacts causing flat tires
- Two times more rubber than standard tires

UNIQUE TREAD DESIGN WITH FLAT PROFILE

- Increases stability, while reducing vibrations for better comfort

HEAVY-DUTY CARCASS

- Maximizes tread puncture-resistance to prevent flat tires

NON-MARKING NATURAL RUBBER COMPOUND

- Prevents visible marks on the floor, ensuring a clean working environment
- Reduces chunking and cutting

CAMSO'S PATENTED NON-MARKING ANTI-STATIC (NMAS) TECHNOLOGY

Camso is the first and only tire manufacturer that offers a complete solid tire line-up to overcome the challenges of high intensity applications, where static build-up can cause major safety hazards.

The Solideal RES Xtreme NMAS and Solideal PON 775 NMAS are cured with a cylindrical piece of highly conductive black rubber connected all the way from the steel wheel to the tread face, which acts as a path to dissipate accumulated electricity on every rotation. This anti-static plug is easily noticeable when looking at the tire: there is a black dot on the face of the tread.

