

DIGITAL PRESSURE GAUGE

— MANUAL

1. NOTICE

1. Please check the packaging and appearance after you received the product.
2. Please check the mode and specification of the product. Keep correct electrical connection and mounting method.
3. Please installation WITHOUT power.
4. During using, please notice the technical and operation conditions: the temperature of medium, burst pressure, power supply.
5. This product is a precision device, DO NOT use hard objects to touch the diaphragm or disassemble.
6. During installation, do not install or disassemble strongly, especially the installation of thread.
7. Please install or disassemble with a suitable wrench, Otherwise, the damage is not in the scope of warranty.
8. After starting the gauge, it is a normal phenomenon to take a few minutes to keep it stable and work normally.
9. If the product is out of order, please contact our after-sale technical staff.
10. During installation, the gauge will be affected by installation stress. After installation, please zero clearing.
(!) **The product damage caused by non-professional operation according to the operation regulation is not the scope by the warranty.**

2. WARNING

1. When operation temperature is above 60 degree, please use forced fans or cooling machines, but do not let the cooling air blow to the switch directly.
2. The installation, commissioning and maintenance of this product shall be conducted by qualified engineers or technicians member.
3. If the malfunction or exception of this product is likely to result in a major system accident, please set up an appropriate protective circuit outside to prevent accidents.
4. The company does not undertake any direct or indirect loss other than the product itself.
5. The company reserves the right to change the manual of the product without notice.

3. DESCRIPTION

This gauge is a high-precision and intelligent digital pressure gauge. It has a high-precision sensor and display the pressure accurately in real time, equipped with a large size LCD.

It has a various of features, such as zero clearing, backlight, on/off button, units, low voltage alarm. And it is convenient to install and easy to operate.

The surface and connector of the product is 304SS. It can be used to measure gas, liquid, oil and other non-corrosive mediums of stainless steel.

It applies to these fields: portable pressure measurement, equipment supporting, equipment calibrations.

4. SPECIFICATION

Pressure Range: Refer to selection-table

Pressure Type: Gauge pressure, Negative gauge pressure

Overload Capacity: Range*150% (< 10Mpa)
Range*120% (> 10Mpa)

Acc.: ±0.4%FS or ±0.2%FS

Long-term Stability: 0.2%FS/year

Power: 3V (two pieces AAA battery)

Battery Life: 8~12 months

Sampling Rate: 3 times/second

Screen Display: 4-digit LCD screen

Backlight color: White

Compensation Temperature: 0~60°C

Operation Temperature: -20°C~70°C

Screw: M20*1.5 or customized

Connector Material: 304SS or customized

Shell Material: 304 Stainless Steel

Measure Medium: non-corrosive with 304 or 316 stainless steel

Electromagnetic Compatibility: Anti-EMI Design , EN61326

Date Retention : EEPROM

Peak Function: Yes

Other Function:

Pressure units switchable

Zero clearing

Backlight

On/off

5. BUTTON

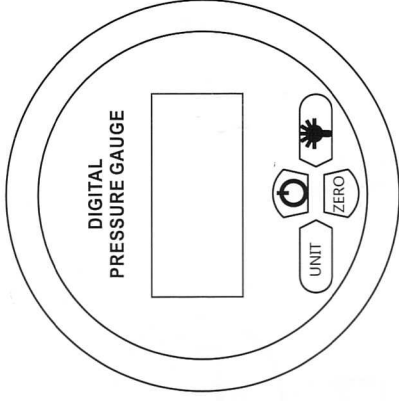

DIAL (80MM) DIGITAL PRESSURE GAUGE

5.1. KEY

KEY	FUNCTION	DESCRIPTION
	ON/OFF	On/off power
	UNIT	Short press to change pressure unit
	BACKLIGHT	Short press to turn on/of backlight, long press to keep backlight on
	ZERO	Press for 4 seconds to zero clearing

5.2. LCD SCREEN

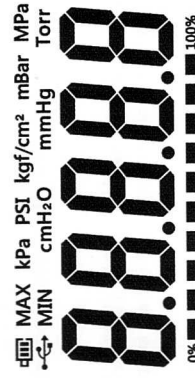

SYMBOL	DESCRIPTION
	kPa
	PSI
	kg/cm²
	Bar
	Mpa
	MAXIMUM
	MINIMUM
	BATTERY
	0%
	100%
	PRESSURE UNIT
	MAXIMUM
	MINIMUM
	BATTERY
	PERCENT

6. SIZE

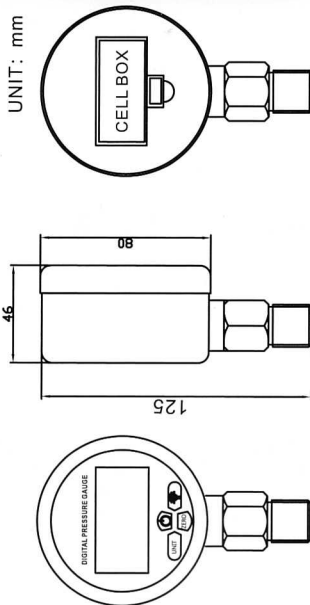

UNIT: mm

DIAL (80MM) DIGITAL PRESSURE GAUGE

7. FUNCTION

1. ON/OFF
Short press to power on, long press to power off.
2. PRESSURE UNITS
Short press to switch units. (Different pressure ranges have different units available)
3. ZERO CLEARING
Without pressure, long press 'ZERO' button for 4 seconds to zero clearing.
4. BACK-LIGHT
Short press back-light button, back-light on for 20 seconds. Long press back-light button for 3 seconds, the back-light will keep on.
5. ADJUST OF FILTER CONSTANT
Short press 'back-light' and 'ZERO' buttons together, it shows 'r-03', and means the filter constant is 03. Then change the value through pressing 'ZERO' button, the value is between 01~10. After setting, press back-light button to save and quit.
Notice: The value smaller, the figure changes more quickly; the value bigger, the figure changes more slowly and the figure more stability.

8. PEAK VALUE

Long press 'UNIT' button for 4 seconds, the screen will show the Maximum value after last zero clearing, then press 'UNIT' button, it will show Minimum value, then press 'UNIT' button to quit.

During show Max or Min value, long press 'ZERO' button to clearing record before, and enter a new record.

9. CODE DESCRIPTION

NO.	CODE	DESCRIPTION
1	E-E	Abnormal sensor communication or sensor damage
2	E-H	Current Pressure Over Range Use or Sensor Damage
3	E-P	Enter pressure calibration procedure, please power off and exit
4	P-C	Enter Temperature Compensation Procedure, Please Turn Off and Exit
5	r-03	Filter constant setting
6	MAX	Maximum
7	MIN	Minimum

10. PROBLEM & SOLUTION

NO.	PROBLEM	REASON	SOLUTION
1	Back-light Dark	Battery power shortage	New Battery
2	Battery Flicker	Battery power shortage	New Battery
3	Pressure Unchanged	1. Pressure block 2. Zero clearing with pressure 3. Sensor Damage	1. Check pressure hole 2. Without pressure, zero clearing 3. Back to Factory
4	E--H	1. Pressure Overload 2. Sensor Damage	1. Notice pressure 2. Back to Factory
5	Figure Change Slowly	Adjust of filter constant	Refer to 7.5
6	Figure Change Quickly	Adjust of filter constant	Refer to 7.5
7	Frequent Pressure Shock	1. Damage Sensor 2. Leakage	Add Buffer Tube
8	High Temperature	1. Damage Gauge 2. Pressure Error	Add Radiator Tube

11. AFTER-SALE SERVICE

The guarantee period of product begins from the data of delivery and lasts for 1 year.

During the guarantee period, if the product itself had quality problems, we would provide free maintenance, exchange and return service.

The content of specific quality guarantee:

1. The spare parts or components of the product are failure, but it can be operate normally after exchange. This is free to repair.
2. The spare parts or components of the product are failure, and it can't be repaired on time. We would exchange a new, same specification of qualified product.
3. The main functions of the product because of design or manufacture is not meet the requirement of the contract or the enterprise standard, the client need to return goods. We should recover the fault product and return thepayment for the goods to the client.

***Disclaimer

During the guarantee period, the product failure caused by followed cases, it beyond the warranty:

1. The failure caused by the inappropriate use of product by user.
2. The client disassemble, repair, refit the product at own discretion.