

Infusion Series ICB Twin Tall Coffee Brewer



Infusion Series ICB Twin Tall

**server sold separately*
Dimensions: 35" x 22" x 20"
(88.9cm x 55.9cm x 50.8cm)

Features

Infusion Series ICB Twin Tall Brewer

- Sleek, modernized design language on the brewer and servers
- Brews into 3.8 and 5.7L (1 to 1.5 gallon) Thermofresh Servers (with base)
- Digital readout displays in English, Spanish, or French ---for easier programming and control--- and can show either 'Standard' or Metric measurements. Digital readout also shows machine status, and targeted advertising messages can be programmed for display.
- Large 5.6 gallon (21.2L) tank provides back-to-back brewing capacity
- Energy-saver mode reduces tank temperature during idle periods
- Electronic funnel lock prevents removal of each brew funnel until drip-through is complete
- Brew counter keeps track of how many batches are brewed
- BUNN Infusion Series technology allows for multiple recipes from one footprint with six brew buttons and three batch sizes
- Pre-infusion and pulse brew for maximum flavor extraction. Cold brew lockout & digital temperature control further ensure top-notch brewing.
- Exclusive Peak Extraction[™] Sprayhead is multi-directional with a 17-hole design to ensure ultimate uniformity of extraction
- USB programming capable
- Hot water faucet (supplied for custom installation)

Related Products

Easy Clear[®] EQ-17-TL

Product No. : 30200.1000
Dimensions:
12⁷/₁₆" H x 2¹/₂" W x 3" D
(31.6 cm H x 6.35 cm W x 7.62 cm D)



Easy Clear[®] ED-17-TL

Product No. : 30201.1001
Dimensions:
8³/₄" H x 2⁵/₁₆" Dia.
(20.95 cm H x 5.87 cm Dia.)

Paper Filter Pack

Product No. : 20115.6000
Packed per case: 1,000
Dimensions:
4¹/₄" Base x 2³/₄" Sidewall
(10.8 cm Base x 6.98 cm Sidewall)



Model

Infusion ICB Twin Tall

Agency Listing



Dimensions & Specifications



Model	Product #	Volts	Amps	Total Watts	Capacity per hour	Cubic ft ³ /m ³	Weight lbs/kg	Cord Attached
Infusion ICB Twin Tall	53200.6101	120/240	25	6050	17.5gal/66L	8.78/0.24	78.4/35.5	No
		120/208	28.9	6050	17.5gal/66L	8.78/0.24	78.4/35.5	No

Capacity: Incoming water temp of 60°F (15.5°C)

Electrical: Requires 3-wires plus ground service rated 120/208V or 120/240V, single phase, 60Hz.

Plumbing: 20-90 psi (138-621 kPa). Supplied with 3/8" male flare fitting.

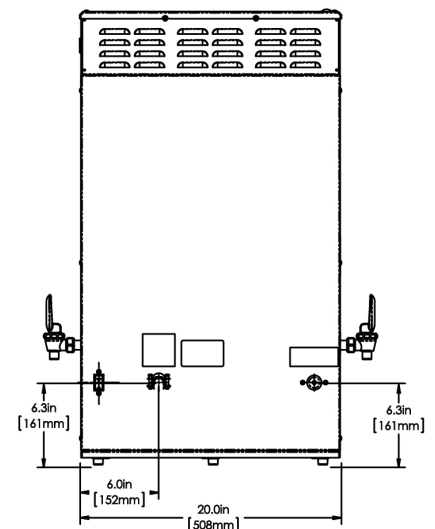
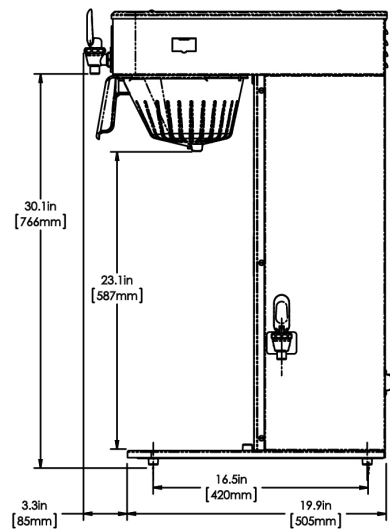
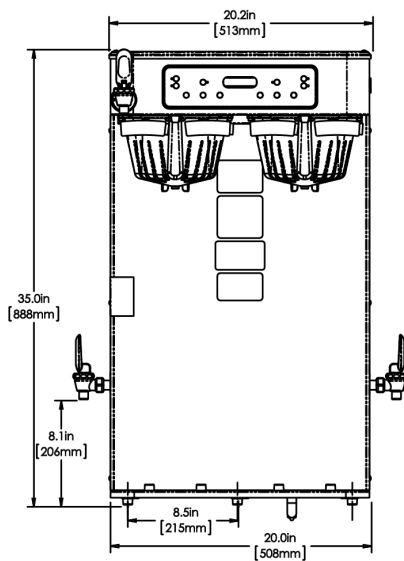
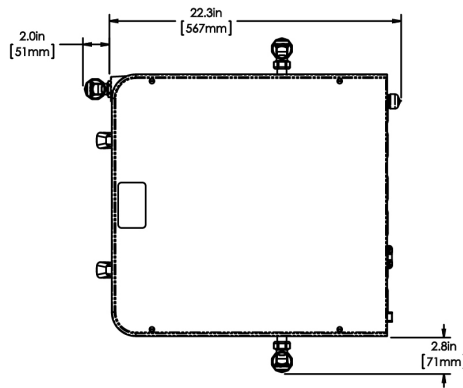

Bunn-O-Matic® Corporation of Canada • 280 Industrial Pkwy South, Aurora Ontario. L4G 3T9 • (905) 841-2866 • www.bunn.com

BUNN® practices continuous product research and improvement. We reserve the right to change specifications and product design without notice. Such revisions do not entitle the buyer to corresponding changes, improvements, additions or replacements for previously purchased equipment.

All dimensions shown in centimeters.