

Thermal Carafe Automatic Coffee Brewer

ITEM# _____

PROJECT _____

DATE _____



Model CWTF15-TC*

(no warmers) (thermal carafe sold separately)
 Dimensions: 17.9" H x 9" W x 18.5" D
 (45.5cm H x 22.9cm W x 55.4cm D)



Model CDBC15-TC

(no warmers) (thermal carafe sold separately)
 Dimensions: 17.9" H x 9" W x 18.5" D
 (45.5cm H x 22.9cm W x 55.4cm D)

Features

12 Cup Automatic Coffee Brewer

- Brews 3.8 gallons (14.4 liters) of perfect coffee per hour.
- Accepts thermal carafe up to 8.5" tall (21.6cm).
- Use in quick turn environment where high quality coffee is continuously refreshed.
- Models are space saving 9.0" wide (22.9cm).
- All stainless steel construction.
- Hot water faucet on all models.
- SplashGard® funnel deflects hot liquids away from the hand.
- CWTF model has pourover feature.

CDBC15-TC Features

- Automatically adjusts to varying water pressure.
- Quicker install with pot level, cold brew lock-out and tank temperature set using the simple-to-program touch pad controls.
- Faster service by use of feedback information from built-in electronic diagnostics.

For current specification sheets and other information, go to www.bunn.com.

* International models may vary in appearance.

Related Products

Easy Clear® EQ-17-TL

Product No. : 30200.1000

Dimensions:

12 $\frac{7}{16}$ " H x 2 $\frac{1}{2}$ " W x 3" D

31.6 cm H x 6.35 cm W x 7.62 cm D



Thermal Carafe

Product No. : 36029.0001

Dimensions: 8"H x 6.4"W x 8.2"D

(20.3cm H x 16.3cm W x 21cm D)



Paper Filter Pack

Product No. : 20115.0000

Packed per case: 1,000

Dimensions: 4 $\frac{1}{4}$ " Base x 2 $\frac{3}{4}$ " Sidewall

10.8 cm Base x 6.98 cm Sidewall



Model	Agency Listing	International Model	Agency Listing
CWTF15-TC	UL NSF	CWTF15-TC	CE
CDBC15-TC	UL NSF		

Dimensions & Specifications

Model	Product #	Volts	Amps	Tank Heater Watts	Total Watts	Brewing Capacity	Cu. Ft.	Shipping Weight	Cord Attached
CWTF15-TC	12950.0360	120	11.4	1320	1370	3.8 gal./hr.	4.2	31 lbs. (14.1 kg)	Yes**
CDBCF15-TC*	29000.0107	120	12.5	1425	1500	4.5 gal./hr.	4.2	28 lbs. (12.7 kg)	Yes**

* Includes a stainless steel funnel † Made-to-order model. Allow extra time to complete order.

**Power cord (NEMA 5-15P) 15 Amp-120V machine only.

Brewing capacity: based upon incoming water temp of 60°F (140°F rise) per 1/2 gallon brew time of 4 minutes.

Electrical: Requires 2-wires plus ground service rated 120V, single phase, 60 Hz.

Plumbing: 20-90 psi (138-621 kPa).
Machine supplied with 1/4" male flare fitting.

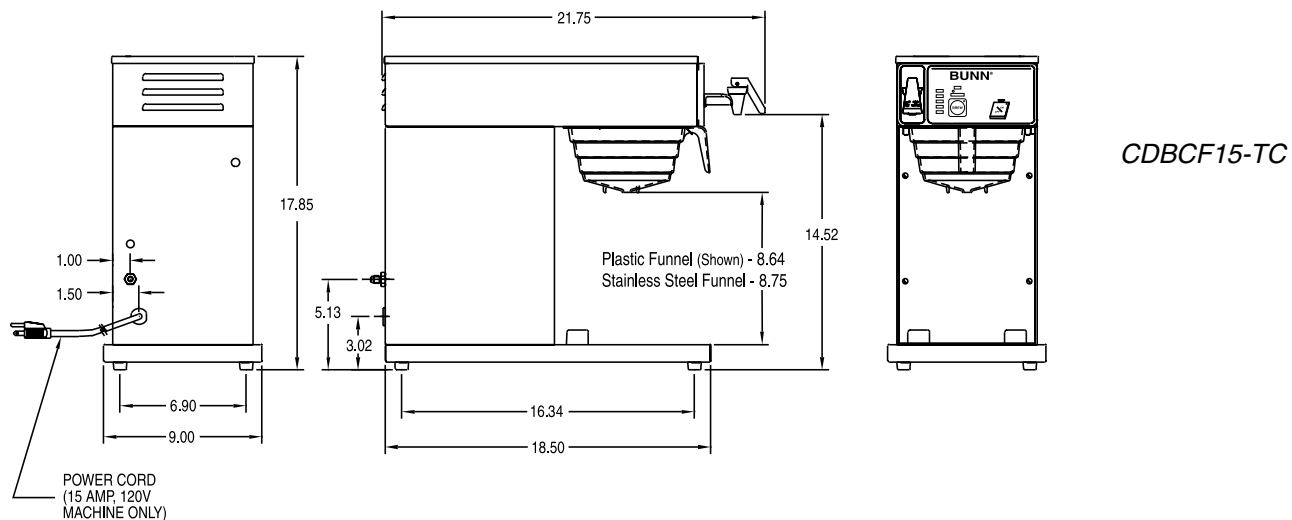
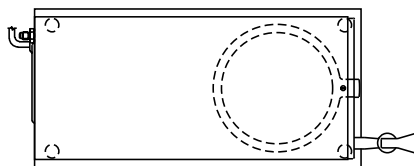
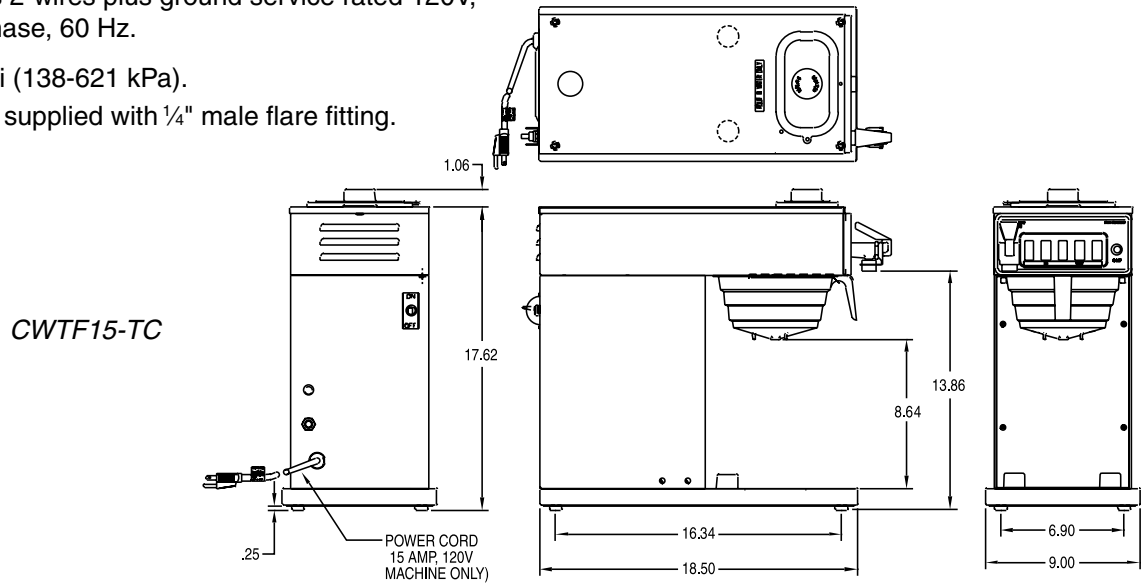

BUNN Corporation - 1400 Stevenson Drive Springfield, Illinois 62703 • 800-637-8606 • 217-529-6601 • Fax 217-529-6644 • www.bunn.com

BUNN® practices continuous product research and improvement. We reserve the right to change specifications and product design without notice. Such revisions do not entitle the buyer to corresponding changes, improvements, additions or replacements for previously purchased equipment.

All dimensions shown in inches. Bunn Corporation owns all copyrights relating to materials in this publication. Please contact Bunn Corporation to request permission to reproduce any portion of this publication.