

Thermal Server Coffee Brewer

Features



Model CWTF TS*
with Thermal Server
(Thermal Server not included)
 Dimensions: 27.6" H x 9" W x 18.5" D
 (70.1cm H x 22.9cm W x 47cm D)

Thermal Server Coffee Brewer

- Brews 3.8 gallons (14.4 liters) of perfect coffee per hour.
- Brewer measures only 9" wide.
- Convenient thermal servers keep coffee hot and fresh for hours.
- Thermal servers are easily transported to remote meeting rooms, breakfast bars, etc.
- Pourover model available (CW15-TS).
- Pourover feature included on automatic models.
- Internal components are constructed from stainless steel.
- Hot water faucet available.
- SplashGard® funnel deflects hot liquids away from the hand.
- Holds up to 4" cup.

For current specification sheets and other information, go to www.bunn.com.

* International models may vary in appearance.

Related Products

Easy Clear® EQ-17-TL
 Product No. : 30200.1000
 Dimensions:
 12⁷/₁₆" H x 2¹/₂" W x 3" D
 31.6 cm H x 6.35 cm W x 7.62 cm D



Easy Clear® ED-17-TL
 Product No. : 30201.1001
 Dimensions:
 8¹/₄" H x 2⁵/₁₆" Dia.
 20.95 cm H x 5.87 cm Dia.



Paper Filter Pack
 Product No. : 20115.0000
 Packed per case: 1,000
 Dimensions:
 4¹/₄" Base x 2³/₄" Sidewall
 10.8 cm Base x 6.98 cm Sidewall



Thermal Server Booster*
 Product No. : 18010.6000
 Capacity: 1 Thermal Server
 Shipping Weight: 2 lbs. (.9 kg)
 Dimensions: 6" H x 9¹/₄" W x 8¹/₄" D
 15.2 cm H x 23.5 cm W x 21 cm D



Thermal Server-Black
 Product No. : 23300.0007
 Capacity: 84 oz. (2.5 L)



*To be used in conjunction with Thermal Server without base. Product No. : 23300.0010 & 23300.0006

Model	Agency Listing	International Model	Agency Listing
CW TS	UL NSF	CWTF A-TS	CE
CWT TS	UL NSF		
CWTF TS	UL NSF		

Dimensions & Specifications

Model	Product #	Volts	Amps	Tank Heater Watts	Total Watts	Brewing Capacity	Cu. Ft.	Shipping Weight	Cord Attached
CW15-TS (Pourover)	23000.0000	120	11.4	1320	1370	3.8 gal./hr.	7.3	27 lbs. (12.3 kg)	Yes†
CWT15-TS (Automatic)	23000.0003	120	11.4	1320	1370	3.8 gal./hr.	7.3	29 lbs. (13.2 kg)	Yes†
CWTF15-TS (Automatic)*	23000.0006	120	11.4	1320	1370	3.8 gal./hr.	7.3	32 lbs. (14.6 kg)	Yes†

*Includes faucet. †Power cord (NEMA 5-15P) 15 Amp-120V machine only.

Brewing capacity: based upon incoming water temp of 60°F (140°F rise) per 1/2 gallon brew time of 4 minutes.

Electrical: 2-wires plus ground service rated 120V, single phase, 60Hz.

Plumbing: 20-90 psi (138-621 kPa). Supplied with 1/4" (6.4 mm) male flare fitting.

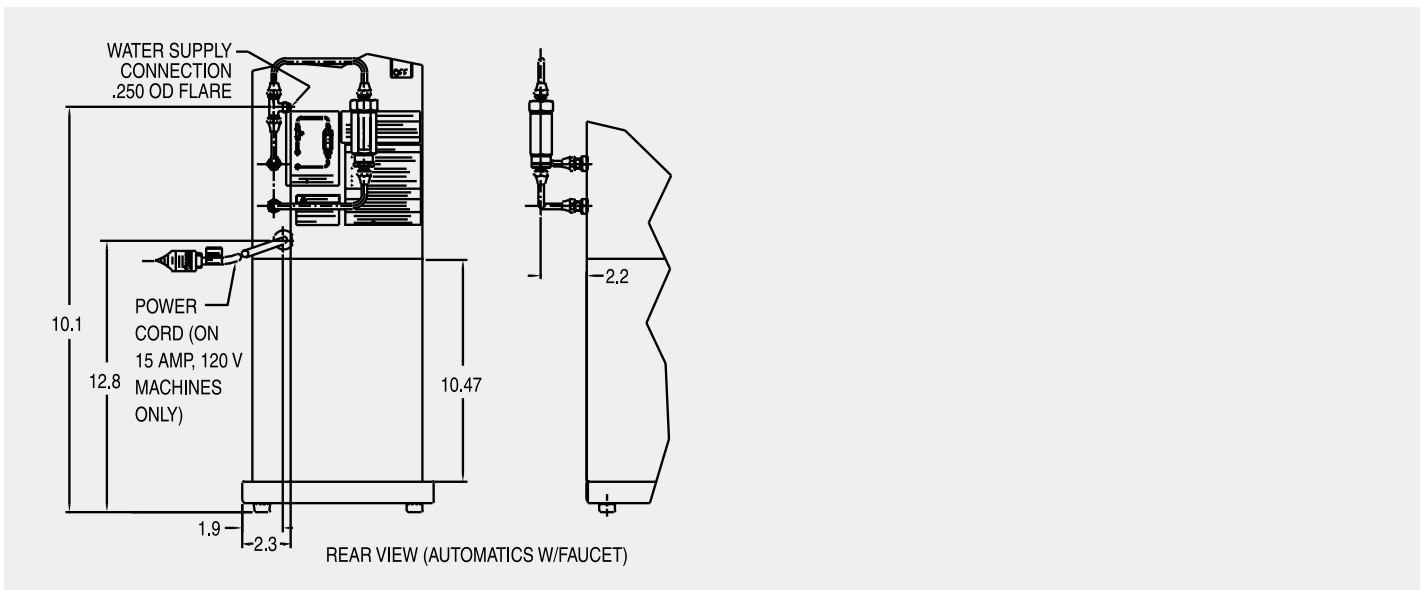
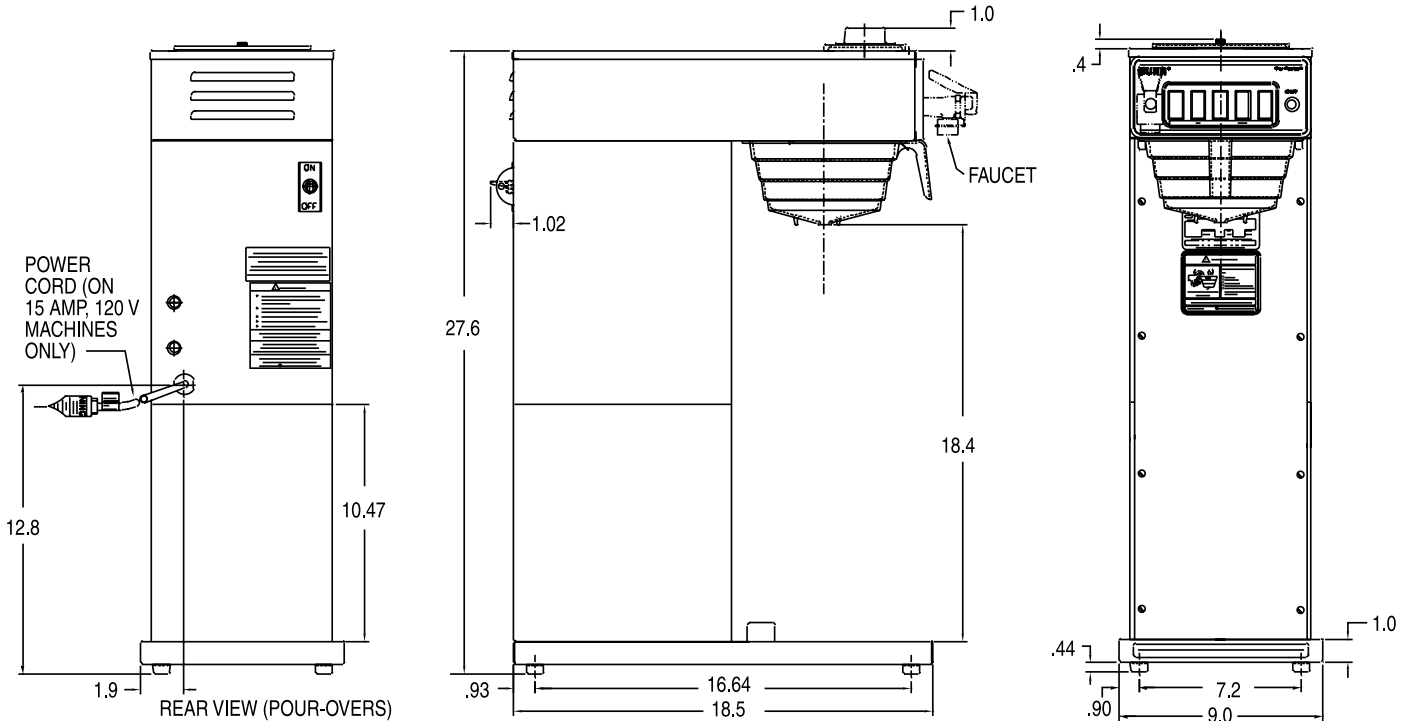

BUNN Corporation - 1400 Stevenson Drive Springfield, Illinois 62703 • 800-637-8606 • 217-529-6601 • Fax 217-529-6644 • www.bunn.com

BUNN® practices continuous product research and improvement. We reserve the right to change specifications and product design without notice. Such revisions do not entitle the buyer to corresponding changes, improvements, additions or replacements for previously purchased equipment.

All dimensions shown in inches. Bunn Corporation owns all copyrights relating to materials in this publication. Please contact Bunn Corporation to request permission to reproduce any portion of this publication.