

ITEM# \_\_\_\_\_

PROJECT \_\_\_\_\_

DATE \_\_\_\_\_

## 12 Cup Automatic Coffee Brewer with 3 Warmers



**Model CWTF15-3T\***  
Shown with decanters  
(decanters sold separately)

Dimensions: 18.9" H x 8.5" W x 17.8" D  
(48cm H x 21.6cm W x 45.2cm D)

### Features

#### 12 Cup Automatic Coffee Brewer

- Brews 3.8 to 7.5 gallons (14.4 to 28.4 liters) of perfect coffee per hour.
- Model is space-saving 8.5" (21.6 cm) wide.
- Black decor construction (stainless steel optional).
- Hot water faucet and pourover feature on all models.
- SplashGard® funnel deflects hot liquids away from the hand.
- International electrical configurations available.
- Model has two top warmers.

For current specification sheets and other information, go to [www.bunn.com](http://www.bunn.com).

\* International models may vary in appearance.

### Related Products

#### Easy Clear® EQ-17-TL

Product No. : 30200.1000  
Dimensions:  
12<sup>7</sup>/<sub>16</sub>" H x 2<sup>1</sup>/<sub>2</sub>" W x 3" D  
31.6 cm H x 6.35 cm W x 7.62 cm D



#### Easy Clear® ED-17-TL

Product No. : 30201.1001  
Dimensions: 8<sup>1</sup>/<sub>4</sub>" H x 2<sup>5</sup>/<sub>16</sub>" Dia.  
20.95 cm H x 5.87 cm Dia.



#### Paper Filter Pack

Product No. : 20115.6000  
Packed per case: 1,000  
Dimensions: 4<sup>1</sup>/<sub>4</sub>" Base x 2<sup>3</sup>/<sub>4</sub>" Sidewall  
10.8 cm Base x 6.98 cm Sidewall



#### Easy Pour® black decanter

Product No. : 06100.0201  
Quantity: 1 (also packaged in quantities of 3 & 24)



#### Easy Pour® orange decanter (for decaf)

Product No. : 06101.0201  
Quantity: 1 (also packaged in quantities of 3 & 24)



#### WX1-warmer





Product No. : 06450.6000  
One position warmer



#### WX2-warmer

Product No. : 06310.6000  
Two position warmer



Model	Agency Listing	International Model	Agency Listing
CWTF15		CWTFA	CE
CWTF20		CWTFA35	CE 
CWTF35			

## Dimensions & Specifications

CANADA 

Model	Product #	Volts	Amps	Tank Htr Watts	Total Watts	Capacity per hour	Cubic Ft. <sup>3</sup> /m <sup>3</sup>	Weight lbs./kg.	Cord Attached
CWTF15-2*	12950.6033	120	11.5	1150	1350	3.8 gal./14.4 liter	3.9/.12	32 / 14.5	Yes
CWTF15-3T**	12950.6037	120	12.5	1150	1450	3.8 gal./14.4 liter	3.9/.12	33 / 14.9	Yes
CWTF15-3T*	12950.6038	120	12.5	1150	1450	3.8 gal./14.4 liter	3.9/.12	33 / 14.9	Yes
CWTF35-3T*	12950.6053	120/240	17.1	3500	3800	7.5 gal./28.4 liter	3.9/.12	33 / 14.9	No
CWTF35-3T***	12950.6066	120/240	17.1	3500	3800	7.5 gal./28.4 liter	3.9/.12	33 / 14.9	No

\* Black Trunk and Black Plastic Funnel

\*\* Stainless Trunk and Black Plastic Funnel

\*\*\* Black Trunk and Stainless Funnel

**Brewing capacity:** based upon incoming water temp of 60°F (140°F rise) per 1/2 gallon brew time of 4 minutes.

Electrical: Model 15 requires 2-wires plus ground service rated 120V, single phase, 60 Hz.

Model 35 requires 3-wires plus ground service rated 120/208 or 120/240V, single phase, 60 Hz.

Plumbing: 20-90 psi (138-621 kPa). Machine supplied with 1/4" male flare fitting.

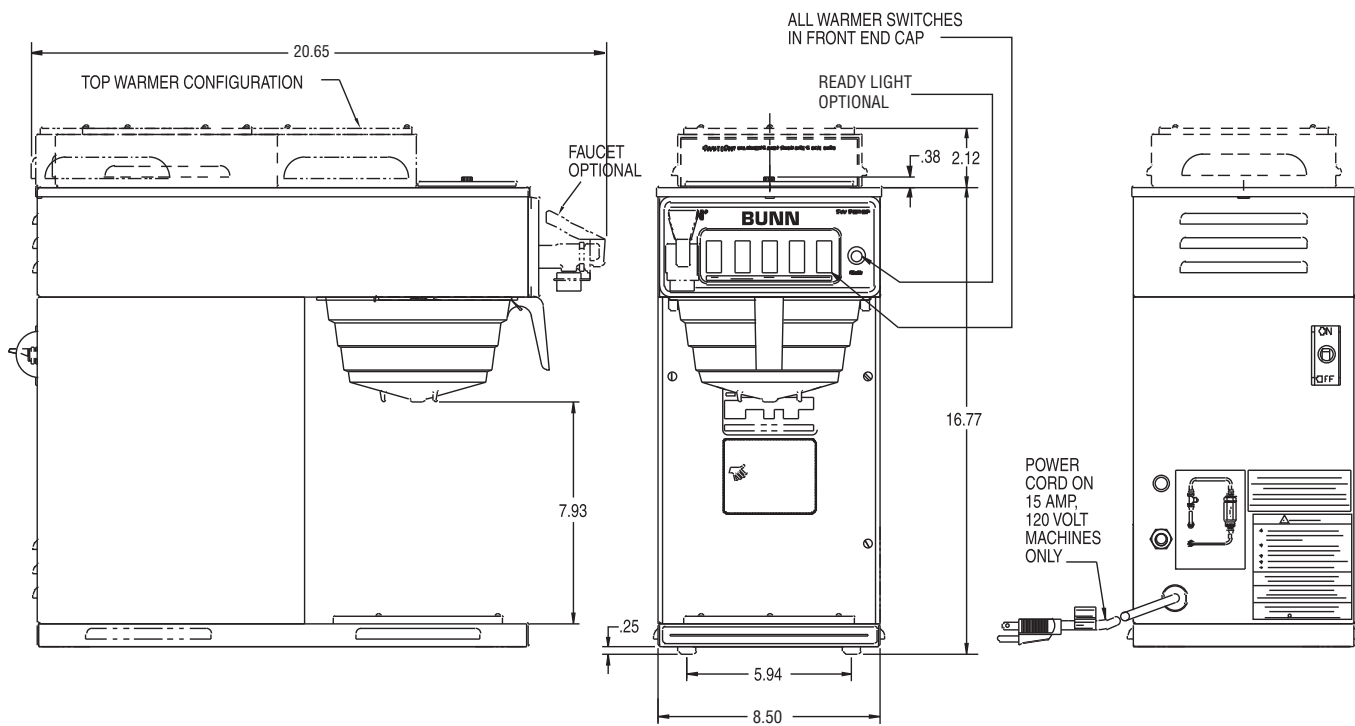

Bunn-O-Matic Corporation of Canada - 280 Industrial Pkwy. S. Aurora, Ontario L4G 3T9 • 905-841-2866 • Fax 905-841-2775 • www.bunn.com

BUNN® practices continuous product research and improvement. We reserve the right to change specifications and product design without notice. Such revisions do not entitle the buyer to corresponding changes, improvements, additions or replacements for previously purchased equipment.

All dimensions shown in inches. Bunn Corporation owns all copyrights relating to materials in this publication. Please contact Bunn Corporation to request permission to reproduce any portion of this publication.