

Infusion Dual Dilution 3 Gallon Iced Tea Brewer



Model ITB Dual Dilution with (2) TDO-N-3.5 Dispensers

(dispensers sold separately)

Dimensions: 34" H x 12.2" W x 22.6" D
(86.4cm H x 30.9cm W x 57.4cm D)

Features

Infusion Dual Dilution 3 Gallon Iced Tea Brewer

- Large tank provides back-to-back brewing capacity and allows 3 or 5 gallon (11.4 to 18.9 litre) tea batches.
- Brews 16.3 to 26.7 gallons (61.7 to 101.1 litres) per hour from real tea leaves.
- Meet your volume needs; brew 3 gallons (11.4 litres) of iced tea into each dispenser and serve up to 6 gallons (22.7 litres) within a narrow footprint.
- Specifically designed to accommodate and brew into two BUNN 3.5 gallon narrow tea dispensers (can also brew directly into standard tea dispensers).
- Includes rotating brew basket, base platform adapter, dedicated dilution nozzles and brew selection switch.
- Color coded decals help the operator properly align the brew basket, dispenser and choose the correct selection.
- Three recipe buttons and full/half options for maximum flexibility.
- Includes two button graphic overlay for customizing the user interface.
- Digital temperature control, pre-infusion, pulse brew and cold brew lockout.
- SplashGard® funnel deflects hot liquids away from the hand.
- Includes Quickbrew (Q) funnel tip for easy conversion.

Sweetener Model Features

- Left side preset with sweetener valve.
- Dilution nozzles labeled "Sweet" and "Unsweet."
- Each brew button's sweetener may be independently set and easily adjusted using the Sweet Meter.
- "Out of Sweetener" indicator - LCD blinks to aid operator.
- Separate inlet for sweetener - use existing CO2 systems or external third party pump for sweetener delivery.

For current specification sheets and other information, go to www.bunn.com.

Related Products

Easy Clear® EQHP-Tea
Product No. : 39000.0007



Easy Clear® EQHP-TEACRTG
Replacement Cartridge
Product No. : 39000.1007

Single/Dual Filter Pack
Product No. : 20100.0000
Packed per case: 500
Dimensions: 5 1/4" Base x 3 3/4" Sidewall
13.34 cm Base x 9.52 cm Sidewall



TDO-N-3.5 – Tea Dispenser
Product No. : 39600.0001
Capacity: 3.5 gallons
Weight: 12.3 lbs.
Dimensions:
21.6" H x 6.2" W x 13.5" D
59.4cm H x 15.7cm W x 34.3cm D



TB6 Funnel
Product No. : 03021.0013

TB6Q Funnel
Product No. : 03021.0014

**TD4T – Dual Reservoir
Tea Dispenser**
Product No. : 03250.0032
Capacity: 4 gallons
Weight: 14.5 lbs.
Dimensions:
22" H x 9.1" W x 15.7" D
55.9cm H x 23.1cm W x 39.9cm D



Model

ITB, DUAL DILUTION

Agency Listing



Dimensions & Specifications

Model	Product #	Volts	Amps	Tank Heater Watts	Total Watts	Brewing Capacity	Cubic Measure	Shipping Weight	Cord Attached
ITB, Dual Dilution	41400.0002	120	14	1680	1700	16.3 gal./hr.*	8.8 ft ³	44 lbs.	Yes†
ITB, Dual Dilution w/sweetener	41400.0003	120	14	1680	1700	16.3 gal./hr.*	8.8 ft ³	44 lbs.	Yes†

†Power cord (NEMA 5-15P) 15 Amp-120V machine only.

* Hourly capacity of 16.3 gallons is for standard funnel tip and delayed dilution. Capacity may be increased to 26.7 gallons/hour using "Q" quick brew funnel tip and no dilution delay.

Electrical: Models require 2-wires plus ground service rated at 120V, single phase, 60 Hz.

Plumbing: 20-90 psi (138-621 kPa). Machine supplied with ¼" OD male flare fitting. Requires minimum of 1 gpm water flow.

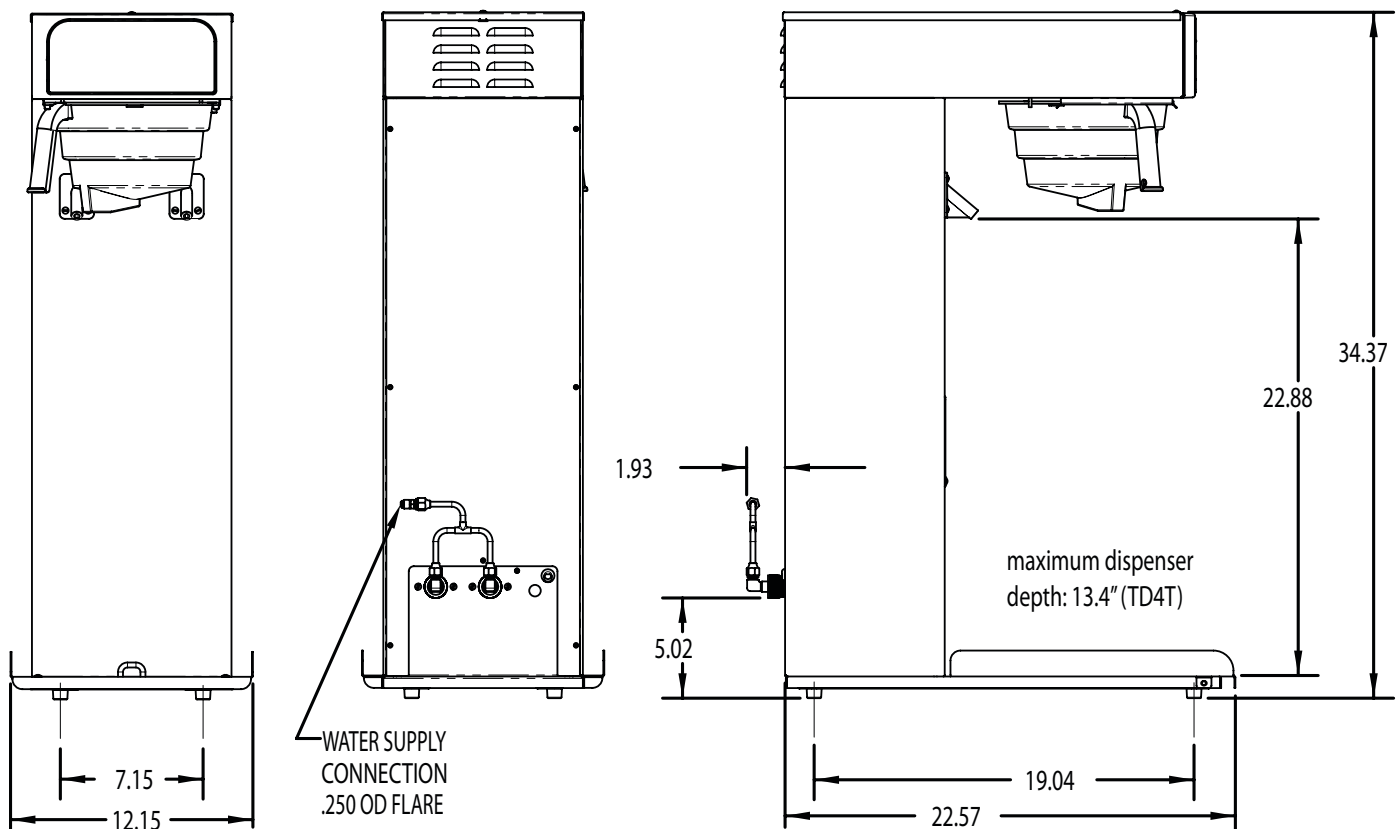

Bunn-O-Matic® Corporation - 1400 Stevenson Drive Springfield, Illinois 62703 • 800-637-8606 • 217-529-6601 • Fax 217-529-6644 • www.bunn.com

BUNN® practices continuous product research and improvement. We reserve the right to change specifications and product design without notice. Such revisions do not entitle the buyer to corresponding changes, improvements, additions or replacements for previously purchased equipment.

All dimensions shown in inches.

9/10 © Bunn-O-Matic Corporation

BUNN®

*ITB/ITCB
ITCB-DV
Infusion Series®*

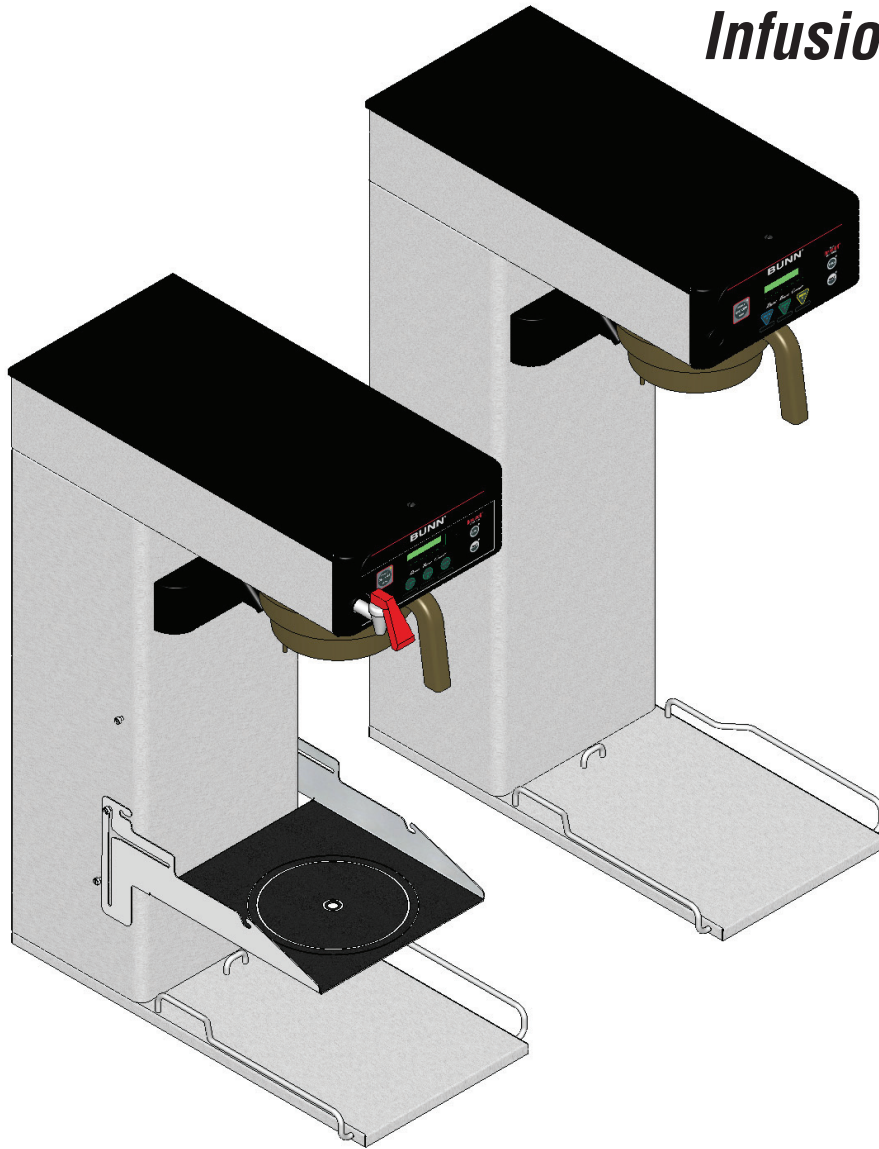

INSTALLATION & OPERATING GUIDE

BUNN-O-MATIC CORPORATION

POST OFFICE BOX 3227

SPRINGFIELD, ILLINOIS 62708-3227

PHONE: (217) 529-6601 FAX: (217) 529-6644

To ensure you have the latest revision of the Operating Manual, or to view the Illustrated Parts Catalog, Programming Manual, or Service Manual, please visit the Bunn-O-Matic website, at www.bunn.com. This is absolutely FREE, and the quickest way to obtain the latest catalog and manual updates. For Technical Service, contact Bunn-O-Matic Corporation at 1-800-286-6070.



BUNN-O-MATIC COMMERCIAL PRODUCT WARRANTY

Bunn-O-Matic Corp. ("BUNN") warrants equipment manufactured by it as follows:

- 1) All equipment other than as specified below: 2 years parts and 1 year labor.
- 2) Electronic circuit and/or control boards: parts and labor for 3 years.
- 3) Compressors on refrigeration equipment: 5 years parts and 1 year labor.
- 4) Grinding burrs on coffee grinding equipment to grind coffee to meet original factory screen sieve analysis: parts and labor for 3 years or 30,000 pounds of coffee, whichever comes first.

These warranty periods run from the date of installation BUNN warrants that the equipment manufactured by it will be commercially free of defects in material and workmanship existing at the time of manufacture and appearing within the applicable warranty period. This warranty does not apply to any equipment, component or part that was not manufactured by BUNN or that, in BUNN's judgment, has been affected by misuse, neglect, alteration, improper installation or operation, improper maintenance or repair, damage or casualty. This warranty is conditioned on the Buyer 1) giving BUNN prompt notice of any claim to be made under this warranty by telephone at (217) 529-6601 or by writing to Post Office Box 3227, Springfield, Illinois 62708-3227; 2) if requested by BUNN, shipping the defective equipment prepaid to an authorized BUNN service location; and 3) receiving prior authorization from BUNN that the defective equipment is under warranty.

THE FOREGOING WARRANTY IS EXCLUSIVE AND IS IN LIEU OF ANY OTHER WARRANTY, WRITTEN OR ORAL, EXPRESS OR IMPLIED, INCLUDING, BUT NOT LIMITED TO, ANY IMPLIED WARRANTY OF EITHER MERCHANTABILITY OR FITNESS FOR A PARTICULAR PURPOSE. The agents, dealers or employees of BUNN are not authorized to make modifications to this warranty or to make additional warranties that are binding on BUNN. Accordingly, statements by such individuals, whether oral or written, do not constitute warranties and should not be relied upon.

If BUNN determines in its sole discretion that the equipment does not conform to the warranty, BUNN, at its exclusive option while the equipment is under warranty, shall either 1) provide at no charge replacement parts and/or labor (during the applicable parts and labor warranty periods specified above) to repair the defective components, provided that this repair is done by a BUNN Authorized Service Representative; or 2) shall replace the equipment or refund the purchase price for the equipment.

THE BUYER'S REMEDY AGAINST BUNN FOR THE BREACH OF ANY OBLIGATION ARISING OUT OF THE SALE OF THIS EQUIPMENT, WHETHER DERIVED FROM WARRANTY OR OTHERWISE, SHALL BE LIMITED, AT BUNN'S SOLE OPTION AS SPECIFIED HEREIN, TO REPAIR, REPLACEMENT OR REFUND.

In no event shall BUNN be liable for any other damage or loss, including, but not limited to, lost profits, lost sales, loss of use of equipment, claims of Buyer's customers, cost of capital, cost of down time, cost of substitute equipment, facilities or services, or any other special, incidental or consequential damages.

AutoPOD, AXIOM, BrewLOGIC, BrewMETER, Brew Better Not Bitter, BrewWISE, BrewWIZARD, BUNN Espresso, BUNN Family Gourmet, BUNN Gourmet, BUNN Pour-O-Matic, BUNN, BUNN with the stylized red line, BUNNlink, Bunn-OMatic, Bunn-O-Matic, BUNNserve, BUNNSERVE with the stylized wrench design, Cool Froth, DBC, Dr. Brew stylized Dr. design, Dual, Easy Pour, EasyClear, EasyGard, FlavorGard, Gourmet Ice, Gourmet Juice, High Intensity, iMIX, Infusion Series, Intellisteam, My Café, PowerLogic, Quality Beverage Equipment Worldwide, Safety-Fresh, savemycoffee.com, Scale-Pro, Silver Series, Single, Smart Funnel, Smart Hopper, SmartWAVE, Soft Heat, SplashGard, The Mark of Quality in Beverage Equipment Worldwide, ThermoFresh, 392, Beverage Bar Creator, Beverage Profit Calculator, BUNNSource, Coffee At Its Best, Digital Brewer Control, Nothing Brews Like a BUNN, Pouring Profits, Respect Earth, Respect Earth with the stylized leaf and coffee cherry design, Signature Series, Tea At Its Best, The Horizontal Red Line, Titan, Ultra are either trademarks or registered trademarks of Bunn-O-Matic Corporation.

INTRODUCTION

ITB

This equipment will brew tea into an awaiting dispenser or reservoir. It is only for indoor use on a sturdy counter or shelf.

The ITB uses recipe settings to brew tea. It has an LCD for digital readout and programming. The user is able to select regular or quick brew for tea programming. Other features include Pre-Infusion and Pulse Brew, quick and standard brew, Energy Savings mode, BUNNLink compatible, Freshness Timer, Sanitation Alert, and brew counters. Available in low profile, dual dilution and sweetener models.

ITCB

This equipment will brew either tea or coffee into an awaiting dispenser or reservoir. It can be easily configured for 120V 15 amp, 120/208V 20 amp or 120/240V 20 amp. The brewer may have an auxiliary hot water faucet. It is only for indoor use on a sturdy counter or shelf.

The Infusion Series combines BrewWISE, CDBC and Tea Brewers into one. ITCB is able to brew both tea and coffee with recipe settings. It has an LCD for digital readout and programming along with the Smart Funnel options for coffee. The user is able to select regular or quick brew for tea programming. Other features include: Pre-Infusion, Pulse Brew, quick and standard brew, and BrewWISE, Energy Savings mode, BUNNLink compatible, Smart Reader compatible, Freshness Timer, Sanitation Alert, and sweetener with low product detection.

CONTENTS

Warranty	2
Introduction	3
User Notices	4
Electrical Requirements	5
Plumbing Requirements	6
Tank Drain	6
Operating Controls	7
Initial Set-Up	8
Tea Brewing	9
Coffee Brewing	9
Cleaning	10
Programming	12

ITB 120V Machine

ITB-LP Low Profile Machine

ITCB-DV Dual Voltage Machine

ITCB-C-DV Dual Voltage Machine for Canada

ITCBA 230 Volt Machine

ITCBB 200 Volt Machine

USER NOTICES

Carefully read and follow all notices in this manual and on the equipment. All labels on the equipment should be kept in good condition. Replace any unreadable or damaged labels.

This equipment must be installed to comply with the International Plumbing Code of the International Code Council and the Food Code Manual of the Food and Drug Administration (FDA). For models installed outside the U.S.A., comply with the applicable Plumbing /Sanitation Code.

#00656.0000



#00824.0000

⚠ WARNING	
 FUNNEL CONTENTS ARE HOT	DISCARD DECANTER IF: <ul style="list-style-type: none"> • CRACKED • SCRATCHED • BOILED DRY • HEATED WHEN EMPTY • USED ON HIGH FLAME OR EXPOSED ELECTRIC ELEMENTS
READ THE ENTIRE OPERATING MANUAL BEFORE USING THIS PRODUCT FAILURE TO COMPLY RISKS INJURY	
PN: 00658.0000G 02/08 © 1985 BUNN-O-MATIC CORPORATION	

#00658.0000

⚠ WARNING
<ul style="list-style-type: none"> • DO NOT OVERLOAD CIRCUIT. • ALWAYS ELECTRICALLY GROUND THE CHASSIS. • DO NOT DEFORM PLUG OR CORD. • FOLLOW NATIONAL AND LOCAL ELECTRICAL CODES. • KEEP COMBUSTIBLES AWAY.
FAILURE TO COMPLY RISKS EQUIPMENT DAMAGE, FIRE OR SHOCK HAZARD.
READ THE ENTIRE OPERATING MANUAL BEFORE USING THIS PRODUCT
00986.0000F 10/07 ©1994 Bunn-O-Matic Corporation

#00986.0000 ITCB ONLY



#00824.0001 ITCB ONLY

⚠ WARNING
To reduce the risk of electric shock, do not remove or open cover. No user-serviceable parts inside. Authorized service personnel only. Disconnect power before servicing.

37881.0000

⚠ CAUTION
For 120/208V or 120/240 volt operation, replace Power Supply Cord only with Bunn-O-Matic part number 01699.0000.

#34072.0000 ITCB ONLY

	⚠ WARNING REMOVE FUNNEL SLOWLY
--	---

#03408.0000

⚠ WARNING
Incorrect programming could result in accidental dispensing of HOT LIQUID.
Trained personnel are to follow instructions provided for software programming.
Use of additional graphic layer requires disabling of appropriate switches.
Read all instructions for additional graphic layer prior to installing and programming.

#34072.0000

	⚠ WARNING HOT LIQUID
--	---------------------------------------

#03409.0000

Optional Field Wiring
120/208-240 V, 13.0-15.0 A, 2650-3500 W 1PH, 3-Wire + GND, 60HZ

#29710.0009 ITCB ONLY

⚠ WARNING
<ul style="list-style-type: none"> ◆ Fill water tank before turning - on - thermostat or connecting appliance to power source. ◆ Use only on a properly protected circuit capable of the rated load. ◆ Electrically ground the chassis. ◆ Follow national/local electrical codes. ◆ Do not use near combustibles.
FAILURE TO COMPLY RISKS EQUIPMENT DAMAGE, FIRE, OR SHOCK HAZARD
READ THE ENTIRE OPERATING MANUAL BEFORE BUYING OR USING THIS PRODUCT
THIS APPLIANCE IS HEATED WHENEVER CONNECTED TO A POWER SOURCE
00831.0000F 3/98 ©1998 BUNN-O-MATIC CORPORATION

#00831.0000 ITB ONLY

Optional Field Wiring
120/208-240 V, 11.5-13.2A, 2390-3180 W 1PH, 3-Wire + GND, 60HZ

#29710.0010 ITCB ONLY

⚠ WARNING HOT LIQUIDS
Make sure Funnel is rotated and aligned with Tea Dispenser on the RIGHT side to avoid potential burns and water spills.
Make sure Funnel is rotated and aligned with Tea Dispenser on the LEFT side to avoid potential burns and water spills.

#41995.0000 ITB ONLY

ELECTRICAL REQUIREMENTS

Refer to Data Plate on the Brewer, and local/national electrical codes to determine circuit requirements.

WARNING - The brewer must be disconnected from the power source until specified.

WARNING - The power cord must be UL Listed, Flexible Cord Type SO, SJO, SJTO, HSJO or SJOW, Rated 90° C, and the attachment plug cap must be UL Listed, in order to avoid a hazard. The Power Supply Cord must be at least 3 feet long and maximum 6 feet long (measured from Strain Relief to end of the Attachment Plug Cap).

120V models require 2-wire, grounded service rated 120 volts AC, 15 amp, single phase, 60Hz.

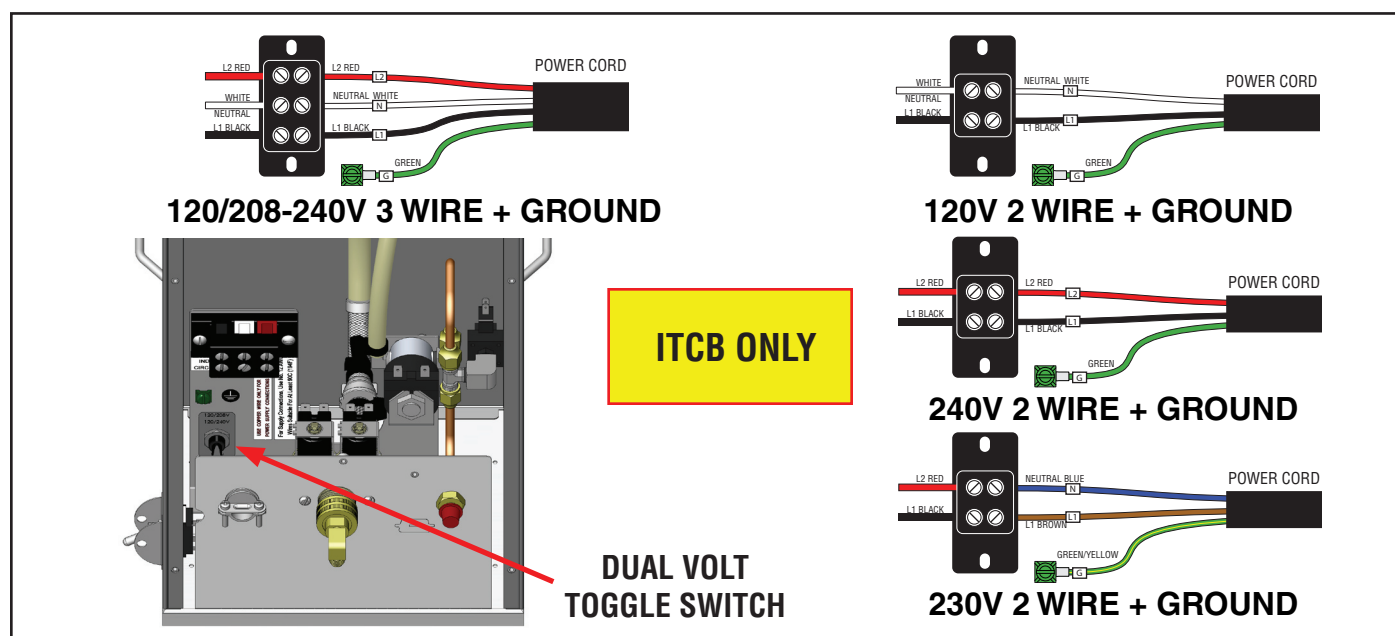

ELECTRICAL HOOK-UP (All Models)

CAUTION – Improper electrical installation will damage electronic components. Damage caused by incorrect electrical connections is not covered by warranty.

1. An electrician must provide electrical service.
2. Determine the available on-site electrical service.
3. (Steps 3-9 apply to DV models only) Select the desired unit voltage based on the available on-site electrical service.
4. Using a voltmeter, check the voltage and color coding of each conductor at the electrical source.
5. Remove the back access panel to gain access to the terminal block.
6. Feed the power cord through the strain relief and connect it to the terminal block(s).
7. Connect the power cord to the terminal block as shown.
8. Before proceeding, verify the voltage at the field wiring terminal block.
9. Set voltage switch to the appropriate position and replace the access panel.
10. If plumbing is to be hooked up later be sure the brewer is disconnected from the power source. If plumbing has been hooked up, the brewer is ready for Initial Set-Up.

CE Requirements:

- This appliance must be installed in locations where it can be overseen by trained personnel.
- For proper operation, this appliance must be installed where the temperature is between 5°C to 35°C.
- Appliance shall not be tilted more than 10° for safe operation.
- An electrician must provide electrical service as specified in conformance with all local and national codes.
- This appliance must not be cleaned by water jet.
- This appliance is not intended for use by persons (including children) with reduced physical, sensory or mental capabilities, or lack of experience and knowledge, unless they have been given instructions concerning use of this appliance by a person responsible for its safety.
- Children should be supervised to ensure they do not play with the appliance.
- If the power cord is ever damaged, it must be replaced by the manufacturer or authorized service personnel with a special cord available from the manufacturer or its authorized service personnel in order to avoid a hazard.

PLUMBING REQUIREMENTS

These brewers must be connected to a cold water system with operating pressure between 20 and 90 psi (138 and 620 kPa) from a 1/2" or larger supply line. A shut-off valve should be installed in the line before the brewer. Install a regulator in the line when pressure is greater than 90 psi (620 kPa) to reduce it to 50 psi (345 kPa). The water inlet fitting is .75-11.5 NH (HOSE THREAD). For convenience an elbow adaptor is provided to convert to a 1/4" flare fitting. Bunn-O-Matic does not recommend the use of a reverse-osmosis or deionized water supply to this equipment. **REQUIRED: 1.25 gpm (4.73 lpm) flow rate from water supply line.**

NOTE - Bunn-O-Matic recommends 3/8" copper tubing for all installations from the 1/2" water supply line. A tight coil of tubing in the water line will facilitate moving the brewer to clean the counter top. Bunn-O-Matic does not recommend the use of a saddle valve to install the brewer. The size and shape of the hole made in the supply line by this type of device may restrict water flow.

This equipment must be installed to comply with the International Plumbing Code of the International Code Council and the Food Code Manual of the Food and Drug Administration (FDA). For models installed outside the U.S.A., you must comply with the applicable Plumbing/Sanitation Code for your area.

Plumbing Hook-Up

1. Remove the shipping cap from the fitting on the rear of the brewer.
2. **STANDARD MODELS:** Securely attach adaptor elbow assembly to the .75-11.5 NH (HOSE THREAD) fitting at the rear of the brewer.
DUAL DILUTION MODELS: Securely attach the tube assembly (supplied in parts box) to water supply line. Securely attach the two elbow assemblies to the .75-11.5 NH (HOSE THREAD) fittings at the rear of the brewer. Connect the tube assembly to the elbows.
3. Flush the water line and Securely attach it to the adaptor elbow.
4. Turn on the water supply.

TANK DRAIN

1. Remove back access cover.
2. Close the white shutoff clamp on the long hose between tank and inlet solenoid.
3. Disconnect the hose clamp and hose from inlet solenoid or check valve.
4. Place the end of the drain hose in a container that has a minimum capacity of 2.0 gallons (7.5 L).
5. Release the white clamp to drain water from the tank.
6. When tank is empty, replace the hose onto solenoid, and tighten the clamp.
7. Replace the back access cover.

OPERATING CONTROLS

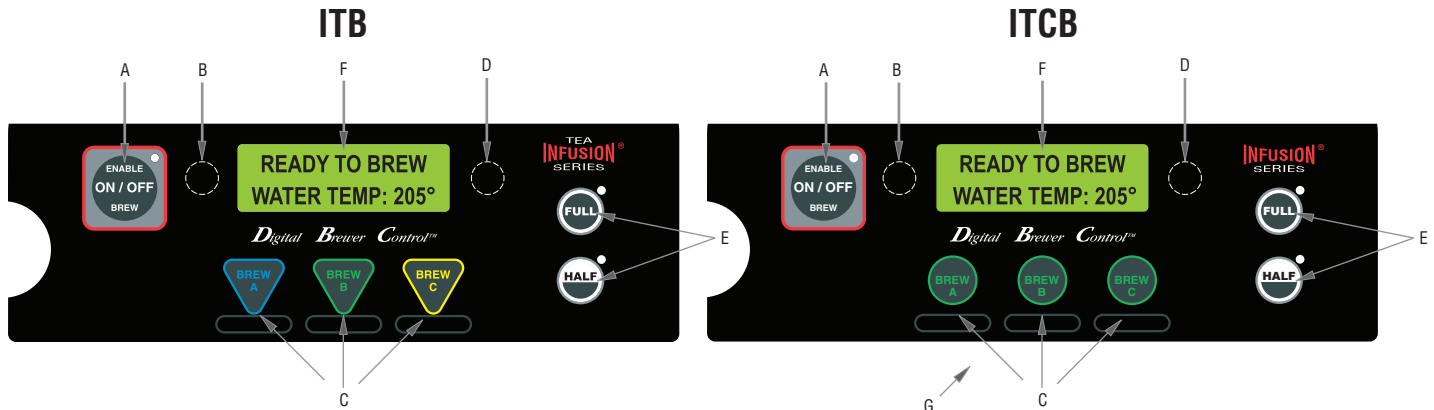

A. ENABLE BREW (ON/OFF) SWITCH

Pressing the ENABLE BREW (ON/OFF) switch pad will alternately turn the brewer on and off. Pressing this pad during the brew cycle will interrupt the brew cycle, stopping the flow of water. Pressing this pad during programming of the brewer will exit the setup and return to the main screen.

B. PROGRAMMING (left)

This hidden pad can be used to scroll backwards through the function list while in programming mode.

C. BREW (A,B,C) and FUNCTION

When the ENABLE BREW is ON and the brewer is on the main screen (not in programming mode), momentarily pressing and releasing this pad will begin a brew cycle. These are also used to program the brewer when in the programming mode.

D. PROGRAMMING (right)

Pressing and holding this pad allows entry into the programming menus. Pressing and releasing the pad steps through each function screen while in the programming mode.

E. BATCH SELECTOR PADS

Pressing the pad corresponding to the Half or Full batch selects the amount of product to be brewed. Pressing a different pad after a brew cycle has been initiated does not change the brew batch in progress. Light indicates the selected batch to brew. Also used in programming to adjust settings on both batch sizes.

F. FUNCTION SCREEN

This is the display which shows the various functions of the brewer and allows the programming to be accomplished.

G. FUNNEL SENSING COIL (ITCB ONLY)

This is used to "receive" information from the Smart Funnel handle, recipe cards, and ad cards.

INITIAL SET-UP

1. Insert an empty funnel into the funnel rails.
2. Place an empty server under the funnel.
3. Connect the brewer to the power source. Make sure the ON/OFF switch is ON (LED will be lit).
4. Water will flow into the tank and stop when the tank is filled to its capacity. Display will show **PLEASE WAIT...TANK FILLING** until tank is filled with water.
5. Wait approximately twenty minutes for the water in the tank to heat to the proper temperature. Display will show **READY TO BREW...WATER TEMP: 205°** when tank is at operating temperature. Some water will drip from the funnel during this time; this is due to expansion and should not occur thereafter.
6. **MODELS w/FAUCET:** Place a small container beneath the faucet and open the faucet handle. Release it when you hear the tank refilling.
7. Water volumes and flow settings have been preset at the factory. Refer to the Programming Manual should the volume need to be increased or decreased.
8. The brewer is now ready for use in accordance with the instructions for Tea Brewing and Coffee Brewing.

Brew water temperature is factory set at 200° F (93.3° C)
 Areas of high altitude will require lowering this temperature to prevent boiling. This chart should be used as a guide when readjusting the brew water temperature.

Altitude (Feet)	Boiling point of water		Recommended water temperature	
	° F	° C	° F	° C
-1000	213.8	101.0	200	93.3
-500	212.9	100.5	200	93.3
0	212.0	100.0	200	93.3
500	211.1	99.5	200	93.3
1000	210.2	99.0	200	93.3
1500	209.3	98.5	200	93.3
2000	208.4	98.0	200	93.3
2500	207.4	97.4	200	93.3
3000	206.5	96.9	199	92.8
3500	205.6	96.4	198	92.2
4000	204.7	95.9	197	91.7
4500	203.8	95.4	196	91.1
5000	202.9	94.9	195	90.6
5500	201.9	94.4	195	90.6
6000	201.0	93.9	194	90.0
6500	200.1	93.4	193	89.4
7000	199.2	92.9	192	88.9
7500	198.3	92.4	191	88.3
8000	197.4	91.9	190	87.8
8500	196.5	91.4	189	87.2
9000	195.5	90.8	188	86.7
9500	194.6	90.3	187	86.1
10000	193.7	89.8	186	85.6

VIEWING ASSIGNED RECIPES

1. Make sure the ON/OFF switch is OFF (LED will not be lit).
2. Press and hold BREW A. The display will show the name of the recipe assigned to Brew A along with SWITCH NOT ON. This is to indicate that a brew cannot be initiated while the ON/OFF switch is OFF.
3. Repeat for BREW B and BREW C.

TEA BREWING

1. Begin each brew cycle with a clean empty brew funnel and server. (Be sure the server lid doesn't interfere with the flow of dilution water.)
2. Insert a BUNN filter into the funnel.
3. Pour the packet of loose fresh tea leaves into the filter. Approximately three to five ounces is recommended for three gallons of beverage.
4. Level the bed of tea leaves by gently shaking.
5. Slide the funnel into the funnel rails until it stops. On dual dilution models, rotate the funnel handle left or right to align the funnel discharge over the reservoir.
6. The ON/OFF must be ON. Select which batch size to brew.
7. Momentarily press and release the assigned BREW switch. There may be certain situations in which the brew cycle will not begin when BREW is pressed:
 - a. **SWITCH NOT ON** - ON/OFF must be ON.
 - b. **BREW TEMPERATURE TOO LOW** – wait until heated or cancel **BREW LOCKOUT** option.
 - c. **CHECK FUNNEL** – remove funnel, empty previously brewed leaves and replace with fresh tea leaves.
 - d. **DISABLED** - select different brew switch or batch size.
8. If none of the above messages are displayed, the display will read **NOW BREWING** and show the time remaining in the brew cycle.
9. Following the brew will be a countdown of drip time **DRIPPING** which shows the time remaining until the tea no longer drips from the funnel tip.
10. Carefully remove the brew funnel and discard the tea leaves and filter only after visible dripping stops.

COFFEE BREWING (ITCB ONLY)

WITHOUT A SMART FUNNEL AND G9-2T DBC GRINDER:

1. Begin each brew cycle with a clean empty brew funnel.
2. Insert a BUNN filter into the funnel.
3. Pour the fresh coffee into the filter and level the bed of grounds by gently shaking.
4. Slide the funnel into the funnel rails until it stops.
5. Place an empty server under the funnel.
6. The ON/OFF must be ON. Select the FULL batch size.
7. Momentarily press and release the assigned BREW switch. There may be certain situations in which the brew cycle will not begin when BREW is pressed:
 - a. **SWITCH NOT ON** - ON/OFF must be ON.
 - b. **BREW TEMPERATURE TOO LOW** – wait until heated or cancel **BREW LOCKOUT** option.
 - c. **CHECK FUNNEL** – remove funnel, empty previously brewed grounds and replace with fresh.
 - d. **DISABLED** - select different brew switch or batch size.
 - e. **COFFEE FUNNEL?** – appears when brew volume is greater than 86.0 oz. (2.54 L) and pulse brew is disabled. Check to make sure the correct funnel is in place, and then press BREW again.
8. If none of the above messages are displayed, the display will read **NOW BREWING** and show the time remaining in the brew cycle.
9. Following the brew will be a countdown of drip time **DRIPPING** which shows the time remaining until the coffee no longer drips from the funnel tip.
10. Carefully remove the brew funnel and discard the grounds and filter only after visible dripping stops.

WITH A SMART FUNNEL AND G9-2T DBC or MHG GRINDER: (ITCB ONLY)

1. Select the small batch size on the grinder.
2. Insert a BUNN filter into the funnel.
3. Grind the selected amount of fresh coffee into the Smart Funnel using the G9-2T DBC or MHG with Smart Funnel operation and level the grounds by gently shaking.

- Slide the funnel into the funnel rails. The brewer will read the coffee name and size ground through the chip in the funnel handle.

NOTE: The brewer will automatically match the brew batch size to the grinder batch size:

<u>GRINDER</u>	<u>BREWER</u>
Small	Half Batch
Medium	Full Batch
Large	*Full Batch

*If BREW is pressed with a large grinder batch, the display will read: **INCORRECT GRIND...BATCH SIZE WRONG**, and then **PRESS BREW TO BREW ANYWAY**.

- Place an empty server under the funnel.
- The ON/OFF must be ON.
- Momentarily press and release the assigned BREW switch. There may be certain situations in which the brew cycle will not begin when BREW is pressed:
 - SWITCH NOT ON** - ON/OFF must be ON.
 - BREW TEMPERATURE TOO LOW** – wait until heated or cancel **BREW LOCKOUT** option.
 - CHECK FUNNEL** – remove funnel, empty previously brewed grounds and replace with fresh.
 - INCORRECT GRIND** - Indicates a large batch was ground using the grinder. Check batch size and grind weight.
- If none of the above messages are displayed, the display will read **NOW BREWING** and show the time remaining in the brew cycle.
- Following the brew will be a countdown of drip time **DRIPPING** which shows the time remaining until the coffee no longer drips from the funnel tip.
- Carefully remove the brew funnel and discard the grounds and filter only after visible dripping stops.

CLEANING

CAUTION – CLEAN AND SANITIZE YOUR ICED TEA BREWER **DAILY**

- Remove and thoroughly clean the entire brew funnel. The funnel tip and screen must be free from any tea particles or residue. Reassemble the funnel.
- Remove and thoroughly rinse the sprayhead. The holes must be open and clear of any mineral deposits. Wipe the sprayhead panel clean with a damp cloth.

NOTE – Any buildup on the sprayhead may restrict water flow, and impact your brewing. For consistently great tea and coffee, clean sprayhead weekly with sprayhead cleaning tool (#38227.0000). Upon visual inspection it may appear that light passes through all holes in the sprayhead, but a thin film of residue can pass light and still impede water flow.

- Remove sprayhead from brewer.
 - Use the pointed end of sprayhead cleaning tool to remove any mineral deposits from the sprayhead holes.
 - Insert the long end of sprayhead cleaning tool into the sprayhead fitting, and rotate several times to remove any mineral deposits from the fitting.
- The use of a damp cloth rinsed in any mild, nonabrasive, liquid detergent is recommended for cleaning all surfaces on Bunn-O-Matic equipment. Do **NOT** clean this equipment with a water jet device.

CAUTION – DO NOT KEEP BREWED ICED TEA OVERNIGHT. THE SERVER MUST BE CLEANED DAILY.

SANITIZING OPTIONAL SWEETENER

All Models:

1. Remove all the quick disconnects (QCD) from all the B.I.B. containers.
2. Fill a suitable pail or bucket with a warm soapy tap water solution. (140° F)
3. Submerge all disconnects (gas and liquid) in the soapy solution and then clean them using a nylon bristle brush. (Do not use a wire brush). Rinse with clean water.
4. Using a plastic pail, prepare approximately five (5) gallons of Kay-5 (or equivalent) sanitizing solution with at least 100 ppm of available chlorine in 120° F water.
5. Rinse the B.I.B. disconnects (QCD's) in the sanitizing solution.
6. Special sanitizing fittings must be attached to each B.I.B. disconnect (QCD's). If these fittings are not available, the fittings from empty B.I.B. bags can be cut from the bags and used. These fittings open the "disconnect" so the sanitizing solution can be drawn through the disconnect opening.
7. Place all the B.I.B. disconnects (QCD's) into the pail of sanitizing solution.

Models with factory installed sweetener:

8. Press and hold the left hidden switch until the display reads: "SanitizeSweetnr?" Press "YES". Next screen will ask "CONTAINER READY?"
9. Press "YES". Allow solution to flow from dilution nozzle for a few seconds.
10. Press any brew switch to stop. Display will read "SOAKING" and count down from 15 minutes. Display will now read "SOAP PURGE"
11. Remove the special sanitizing fittings, or empty, cut B.I.B fittings from the B.I.B. disconnects (QCD's) and re-connect the QCD fittings to the appropriate B.I.B. container. (You will now begin the process of bringing syrup back through the system)
 - a. Place empty tea dispenser under unit
 - b. Place empty brew basket into funnel rails
12. Press "START". Next screen will ask "CONTAINER READY?"
13. Press "YES". Continue with brew cycle until syrup is flowing freely from the dilution nozzle.
14. Press any brew switch to stop. Display will read "SANITATION COMPLETE" and return to home screen.

Models with field installed sweetener kit:

8. The next steps are to initiate a brew cycle and draw sanitizer through the system:
 - a. Place empty tea dispenser under unit.
 - b. Place empty brew basket into funnel rails
 - c. Push appropriate brew button for Sweet Tea (brew cycle will initiate)
 - d. Continue with brew cycle until the sanitizing solution is flowing from the dilution nozzle.
 - e. Push the "Enable Brew on/off" button to stop the brew cycle and then push again to cancel the brew cycle
 - f. Allow sanitizer to remain in lines for fifteen (15) minutes.
9. Remove the special sanitizing fittings, or empty, cut B.I.B fittings from the B.I.B. disconnects (QCD's) and re-connect the QCD fittings to the appropriate B.I.B. container. (You will now begin the process of bringing syrup back through the system)
 - a. Place empty tea dispenser under unit
 - b. Place empty brew basket into funnel rails
 - c. Push appropriate brew button for Sweet Tea (brew cycle will initiate)
 - d. Continue with brew cycle until syrup is flowing freely from the dilution nozzle. You may need to repeat steps "a" through "d" until syrup is dispensing from the dilution nozzle.

PROGRAMMING

Using the menu-driven display on the front of the brewer, the operator has the ability to alter or modify various brewing parameters such as brew temperatures, brew volumes, dilution volumes, pulse brew, etc. This allows for the precise brewing of various flavors of tea and coffee.

Programming of the brewer is achieved by entering a certain function. Then, by the use of hidden programming switches and the brew/function switches, the operator can customize the brewing process to their specifications.

PROGRAMMING SWITCHES

To access the programming mode, and to scroll through the different function screens, hidden programming switches are used. There are five of these switches that will be used for the setup of the brewer.

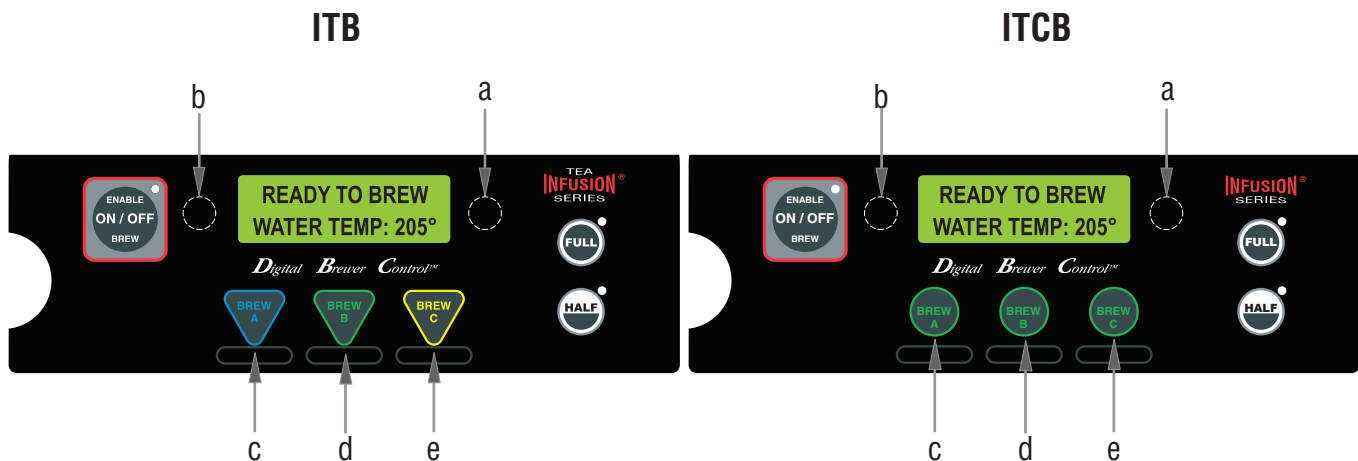

- a) **Right Programming (hidden) switch** (just to the right of the display): This is used to access the programming mode, and is also used to scroll forward through the function list.
- b) **Left Programming (hidden) switch** (just to the left of the display): This is used to scroll backwards through the function list.
- c) **Brew A**: This is used to select options that appear on the display during programming.
- d) **Brew B**: This is used to select options that appear on the display during programming.
- e) **Brew C**: This is used to select options that appear on the display during programming.

For more advanced PROGRAMMING information, refer to programming manual 41581.0002 at www.bunn.com

PROGRAMMING THE BREWER

The programming of the brewer is divided into two levels. There is one function in Level 1. All other functions are accessed in Level 2.

The following function screens are in order of appearance. Each screen will have instructions on how to access and the procedures to program the various functions of the brewer.

IMPORTANT PROGRAMMING NOTES - READ CAREFULLY -

To exit the programming mode at any time, press and release the ON/OFF pad located on the front switch panel. The display will return to the **MAIN SCREEN**.

If none of the five programming switches are pressed within one minute during the setup of the brewer, the programming of the function screen that is being set will be exited and the display will return to the **MAIN SCREEN**.

Always remember to place a container and funnel under the sprayhead when operating the brewer during the set-up of **CALIBRATE FLOW**, and testing the brew and dilution valves in **SERVICE TOOLS/TEST OUTPUTS**.

MAIN SCREEN

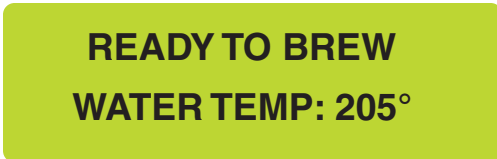

Digital Brewer Control™

This screen will be shown when the brewer is ready for use. The screen displays the water temperature in the tank. When the water in the tank reaches the correct set temperature, the display will change from **HEATING** to **READY TO BREW**.

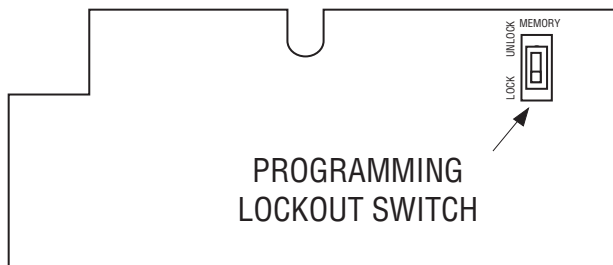

P3048

PROGRAMMING LOCKOUT SWITCH

ITCB-located on the memory module board prior to S/N ICB0007479

located on the main control board S/N ICB0007479 and after)

ITB-located on the main control board

This switch can be set to prevent access to the programming settings of the brewer. Once all the correct brew settings are programmed, the operator can set the switch to the "ON" position to prohibit anyone from changing the settings. With the switch in the "ON" position, the programming menus can still be accessed to view the current settings. However, no changes will be saved.

For more advanced PROGRAMMING information, refer to programming manual 41581.0002 at www.bunn.com

PROGRAMMING FUNCTIONS - FLOW CHART

PROGRAMMING FUNCTIONS - LEVEL 1

BREW LOCKOUT?
NO DONE YES

Digital Brewer Control™

PROGRAMMING FUNCTIONS - LEVEL 2

SET LANGUAGE?
NO YES

Digital Brewer Control™

UNITS
METRIC DONE ENG

Digital Brewer Control™

REVIEW RECIPES
NO YES

Digital Brewer Control™

ASSIGN RECIPE
NO YES

Digital Brewer Control™

MASTER TEMP 205°
(-) DONE (+)

Digital Brewer Control™

READY DEGREE 5°
(-) DONE (+)

Digital Brewer Control™

ENABLE ADS?
NO DONE YES

Digital Brewer Control™

ENABLE SANITATION
NO DONE YES

Digital Brewer Control™

ENABL ENERGYSAVR
NO DONE YES

Digital Brewer Control™

ENABLE FRESH TIMER
NO DONE YES

Digital Brewer Control™

XX REFILL XXX
(-) DONE (+)

Digital Brewer Control™

SPRAY OZ/M: XX.X
(-) DONE (+)

Digital Brewer Control™

DILUTE OZ/M: XX.X
(-) DONE (+)

Digital Brewer Control™

CALIBRATE FLOW?
NO YES

Digital Brewer Control™

BREW COUNTERS?
NO YES

Digital Brewer Control™

ENTER ASSET #
NO YES

Digital Brewer Control™

ENTER SERVICE #
NO YES

Digital Brewer Control™

SERVICE TOOLS
NO YES

Digital Brewer Control™

FACTORY DEFAULTS
NO YES

Digital Brewer Control™

For more advanced PROGRAMMING information, refer to programming manual 41581.0002 at www.bunn.com

PROGRAMMING FUNCTIONS - FLOW CHART

PROGRAMMING FUNCTIONS - LEVEL 1

BREW LOCKOUT?
NO DONE YES
Digital Brewer Control™

PROGRAMMING FUNCTIONS - LEVEL 2

SET LANGUAGE?
NO YES → **UNITS**
METRIC DONE ENG → **REVIEW RECIPES**
NO YES → **ASSIGN RECIPE**
NO YES
Digital Brewer Control™ *Digital Brewer Control™* *Digital Brewer Control™* *Digital Brewer Control™*

→ **SET NEW RECIPE?**
NO YES → **MASTER TEMP 205°**
(-) DONE (+) → **READY DEGREE 5°**
(-) DONE (+) → **ENABLE ADS?**
NO DONE YES
Digital Brewer Control™ *Digital Brewer Control™* *Digital Brewer Control™* *Digital Brewer Control™*

→ **ENABLE SANITATION**
NO DONE YES → **ENABL ENERGYSAVR**
NO DONE YES → **ENABLE FRESH TIMER**
NO DONE YES → **XX REFILL XXX**
(-) DONE (+)
Digital Brewer Control™ *Digital Brewer Control™* *Digital Brewer Control™* *Digital Brewer Control™*

→ **SPRAY OZ/M: XX.X**
(-) DONE (+) → **DILUTE OZ/M: XX.X**
(-) DONE (+) → **CALIBRATE FLOW?**
NO YES → **BREW COUNTERS?**
NO YES
Digital Brewer Control™ *Digital Brewer Control™* *Digital Brewer Control™* *Digital Brewer Control™*

→ **SET RECIPES TEMPS**
NO YES → **ENTER ASSET #**
NO YES → **ENTER SERVICE #**
NO YES → **SERVICE TOOLS**
NO YES
Digital Brewer Control™ *Digital Brewer Control™* *Digital Brewer Control™* *Digital Brewer Control™*

→ **FACTORY DEFAULTS**
NO YES
Digital Brewer Control™

For more advanced PROGRAMMING information, refer to programming manual 41581.0002 at www.bunn.com