

DETAILS

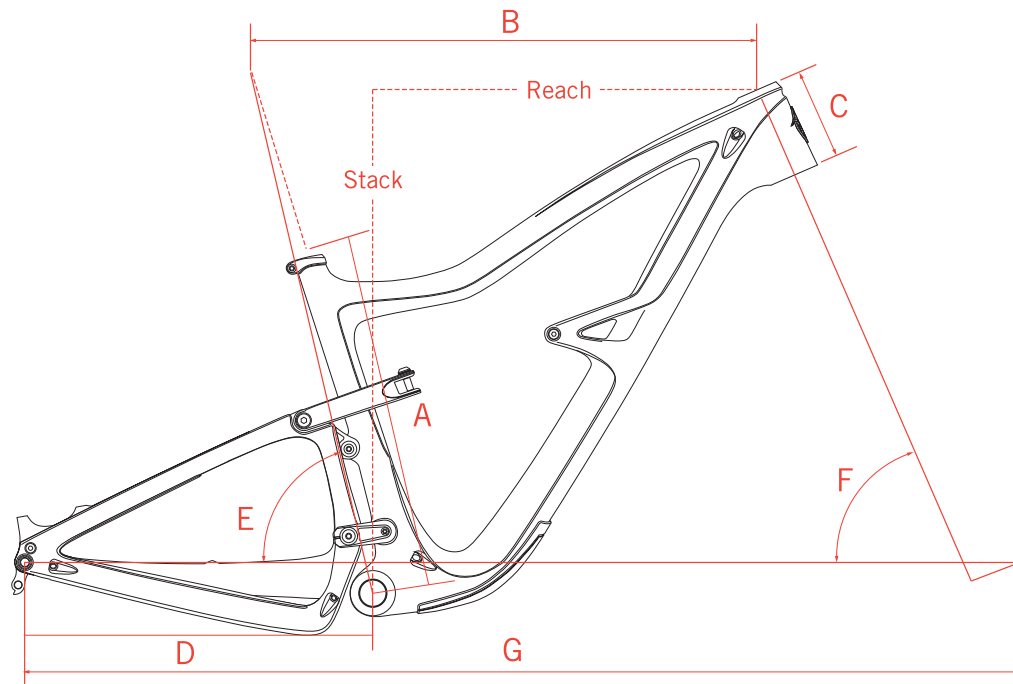

GEOMETRY

130MM FORK (537MM AXLE TO CROWN)

SIZE		SMALL	MEDIUM	LARGE	X-LARGE
SEATTUBE	A	14.5"	15"	16.5"	19"
TOPTUBE	B	574mm	603mm	630mm	658mm
HEADTUBE	C	90mm	105mm	115mm	125mm
CHAINSTAY	D	432mm	432mm	432mm	432mm
SEAT ANGLE	E	76°	76°	76°	76°
HEAD ANGLE	F	66.5°	66.5°	66.5°	66.5°
WHEELBASE	G	1147mm	1178mm	1207mm	1236mm
STACK		599mm	613mm	622mm	631mm
REACH		425mm	450mm	475mm	500mm
STANDOVER		27.9"	28.1"	29.3"	29.8"
TRAIL		4.5	4.5	4.5	4.5

WHAT'S CHANGED

- All new from-the-ground-up redesign
- Ripmo inspired chassis shares similar stiffness and lower link design
- It's now .65 lbs lighter than the Ripley V3
- Headtube is one degree slacker, now 66.5°
- Seat tube is three degrees steeper, now 76°
- Chainstays shortened by 12mm, now 432mm
- Reach increased by an average of ~45mm across all four sizes
- More progressive suspension kinematics
- Removable ICSG 05 mount
- Internal cable tunnels
- 1x specific design

