

# CHILLER DADDY®

MODEL:CHL-501

Intended Use For:

## Residential & Office Water Chiller

---

### OWNER'S MANUAL

#### TABLE OF CONTENTS

1. FOR YOUR SAFETY
2. LOCATION REQUIREMENTS
3. INSTALLATION PROCEDURES
4. PRESSURE LIMITER (optional)
5. CLEANING & SANITIZING
6. STORAGE
7. QUICK CONNECTOR FITTINGS
8. PRIMARY COMPONENTS DIAGRAM
9. ADJUSTING THERMOSTAT
10. SPECIFICATIONS
11. TROUBLESHOOTING GUIDE
12. WARRANTY & SERVICE

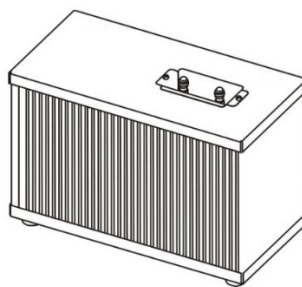

Chiller Daddy LLC  
Huntington, IN 46750 USA  
[www.ChillerDaddy.com](http://www.ChillerDaddy.com)

- ▲ For best use of your Chiller we advise reading these instructions carefully as they contain important information.
- ▲ Keep this manual for future reference.
- ▲ Chiller Daddy LLC reserves the right to change specifications and design without notice.
- ▲ CHILLER DADDY® is the Registered Trademark of CHILLER DADDY LLC

## 1. WARNING - FOR YOUR SAFETY - READ THE FOLLOWING SAFETY PRECAUTIONS BEFORE OPERATING THE WATER CHILLER

- ✓ To prevent electric shock, unplug the Chiller prior to servicing. Never remove the cover while the Chiller is still connected to electricity.
- ✓ Never insert anything into the Chiller cabinet when it is connected to electricity. Prevent water from flowing into the Chiller metal cabinet or onto electrical parts.
- ✓ Do not use with water that is microbiologically unsafe or of unknown quality.
- ✓ When carrying or tilting the Chiller never tilt more than 45 degrees in any direction. Always allow the Chiller to stand fully upright for 4 hours before connecting to electricity to allow the compressor's lubricant to settle. **Failure to do so may cause compressor failure.**
- ✓ In case of failure, cut off the power and water supply immediately, and contact an authorized service center or Chiller Daddy at [info@chillerdaddy.com](mailto:info@chillerdaddy.com).
- ✓ **WARNING: GROUNDING SAFETY PRECAUTIONS AND INSTRUCTIONS** - The Chiller must be grounded – if the appliance is improperly grounded, the result could be electric shock. To provide additional protection from the risk of shock, the Chiller **MUST** be connected to a ground fault circuit interrupter (GFCI) outlet at all times. Do not use an extension cord or 3 prong adaptor. Ensure that the Chiller is set up so access to the power outlet and plug is unobstructed. If the supply cord is damaged, it must be replaced by the manufacturer, its service agent or similarly qualified persons in order to avoid a hazard.
- ✓ **IMPORTANT:** The customer acknowledges that water, like other liquids, can cause damage to surfaces. The customer takes full responsibility for placing the Chiller within a residence or business and acknowledges that failure to address drips, leaks or spillages is at the customer's risk.
- ✓ The Chiller is not to be used by persons (including children) with reduced physical, sensory or mental capabilities, or lack of experience and knowledge, unless they have been given supervision or instruction. Children being supervised are not to play with the Chiller.
- ✓ Be certain to check the drain plug on the bottom of the Chiller to insure that it is tight and does not leak. Shipping and handling may have caused the drain plug to loosen.

## 2. LOCATION REQUIREMENTS

- ✓ This Chiller is intended to be installed underneath a conventional kitchen sink, in a cabinet not less than 36" (914mm) wide (inside dimension). Chiller Daddy® may be installed in any location in the cabinet base as long as there is a minimum of 5" (127mm) between the Chiller and the cabinet walls. In order to have necessary air exchange for the Chiller, a free air opening of at least 60 square inches (387 cm<sup>2</sup>) should be provided in the kitchen cabinet to allow heat to escape. The opening should be located as close to the Chiller as possible.
- ✓ Make sure the cabinet floor is flat and even where the Chiller is to be installed. An unbalanced installation may cause noise and vibration of the Chiller. All 4 vibration absorbing feet should be in firm contact with the cabinet floor. Be sure the cabinet floor is strong enough to support the Chiller when filled with water.
- ✓ Do not install the Chiller where the temperature will go below 50° F (10° C) or above 100° F (38° C).
- ✓ Ensure that the supply water pressure rating is suitable for use with the application (15~100 PSI (100~690kPa)).
- ✓ Check the available power supply against the Chiller data plate to assure correct electrical service.
- ✓ Chiller Daddy is for indoor use only. Keep away from direct sunlight and excessive humidity. Avoid harmful gas, chemicals, moisture or excessive heat. Do not store explosive substances such as aerosol cans with a flammable propellant with the Chiller.

## 3. INSTALLATION PROCEDURES

- ✓ Do not plug Chiller in to the electrical outlet before connecting the Chiller to the water supply. If you need to unplug the Chiller wait at least 5 minutes before plugging in again.
- ✓ Remove the Connector Plugs from the Quick Connector Union on the stainless steel water inlet and outlet tubes on the top of the Chiller. See Section 7, Step 4 for instructions on Tube and Plug removal from Quick Connector Union fittings. Save for possible future use.
- ✓ Connect the 1/4" OD tube from the outlet line of the Reverse Osmosis or Water Filtration system to the water inlet of the Chiller by using the Quick Connector Unions. (see Section 7) The tubing must be acceptable for use with potable water. Flush water through the lines of the Chiller and drinking water system for one minute before installing the faucet. Use 1/4" OD tubing to connect the water outlet of the Chiller to the faucet. Adaptors to

allow 3/8" OD lines to connect the faucet are acceptable.

- ✓ Purge off all air from the water lines by slowly opening the faucet lever. A steady water stream of water assures all air is purged.
  - ✓ Prior to drinking, flush water through Chiller for at least 2 minutes. Close the faucet and check all water tight connections.
  - ✓ Plug in the Chiller and you will be able to enjoy cold water in about 30 minutes after completing installation.
- CAUTION: TO PREVENT PROPERTY DAMAGE DUE TO WATER LEAKAGE, SEEK INSPECTION BY A PLUMBER TO CONFIRM THAT THE WATER PRESSURE IS LESS THAN 100PSI (690KPA) BEFORE YOU CONNECT THE SUPPLY WATER. CAUTION: FAILURE TO ABIDE BY ABOVE PROCEDURE CAN CAUSE PHYSICAL DAMAGE TO THE CHILLER AND POSSIBLY CAUSE WATER LEAKS.**

#### 4. PRESSURE LIMITER (optional)

- ✓ An optional 30 -50 psi (factory preset to 40 PSI) pressure limiter is available for the Chiller for use in certain applications. The pressure limiter is not needed if Chiller Daddy® is installed on a typical residential reverse osmosis RO system. Even though Chiller Daddy® is rated for 100 PSI maximum inlet water pressure we suggest using the pressure limiter if there are possible "water hammer" pressure spikes. Pressure limiters help protect plumbing systems from water hammer pressure spikes in a similar way that surge suppressors protect electronics from damage by electrical spikes. The Pressure Limiter allows you to adjust the strength of the water flow to your desired faucet level. 30 – 50 PSI allows you to choose a very strong flow or a softer flow as the water comes out of the faucet.

#### 5. CLEANING & SANITIZING

- ✓ Keep the black radiant condensers dust free for maximum water chilling and longest system life. Use a vacuum cleaner with a long bristle brush attachment to remove dust from the black condenser grid on both sides as needed.
- ✓ For cleaning and sanitizing the drinking water pathway we suggest doing it in conjunction with the routine maintenance on your Reverse Osmosis RO system or drinking water system. Any sanitizing solution approved for your RO system will work well with the Chiller Daddy® stainless steel waterway, such as Pro Products Sani System Water Filtration System Sanitizer.

#### 6. STORAGE

- ✓ When not in use for a long period of time, conduct cleaning before putting in storage and again before returning to use.
- ✓ Unplug power cord. Open faucet until water is room temperature.
- ✓ Close the source water inlet valve.
- ✓ Disconnect the water tubes from the water Chiller. See Section 7, Step 4 for instructions on tube removal from quick connection fittings.
- ✓ Place a bucket beneath the drain cap on the bottom of the Chiller. Open the drain cap and drain the remaining water from the tank. Reinstall the drain cap. **CAUTION: BE SURE TO SECURELY REINSTALL THE DRAIN CAP TO PREVENT LEAKAGE AND WATER DAMAGE.**
- ✓ Reinstall the "Connector Plugs" into the water inlet and outlet Quick Connectors to keep the system sealed while storing.
- ✓ Store standing in an upright position on a flat and even surface. (Do not lay Chiller Daddy® on its side, end or upside down.)  
**CAUTION: FAILURE TO ABIDE BY ABOVE PROCEDURE MAY INCUR PHYSICAL DAMAGE TO THE CHILLER'S COMPRESSOR.**
- ✓ TO PROPERLY DISPOSE OF YOUR CHILLER - Your old Chiller may have used a regulated refrigerant in its cooling system. These refrigerants are believed to harm stratospheric ozone. If you are throwing away your old Chiller, make sure the refrigerant is removed and recovered for proper disposal by an EPA-certified technician. If you intentionally release this refrigerant, you can be subject to fines and imprisonment under provisions of environmental legislation.

- ✓ First you must remove the temporary “Connector Plugs” from the water Inlet and Outlet ports of the Quick Connector Unions when installing the Chiller. See Step # 4 below for Tube & Plug removal instructions for Quick Connector fittings.

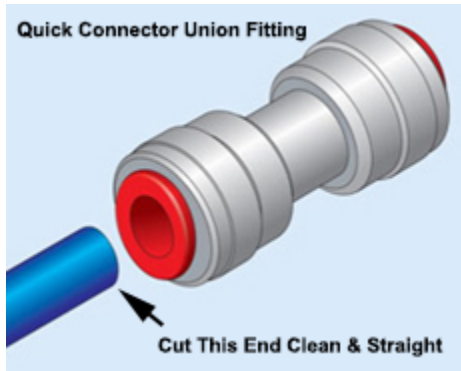

#### Step 1. Cutting the Tube

- Cut the end of the tube to be inserted into the fitting to make the end of the tube be a smooth and straight cut.
- Make sure to start with a clean tube without any foreign material, free of score marks and scratches.
- Use a utility knife with a fresh blade or Tube Cutter. Do NOT use a hacksaw.

#### Step 2. Inserting the Tube

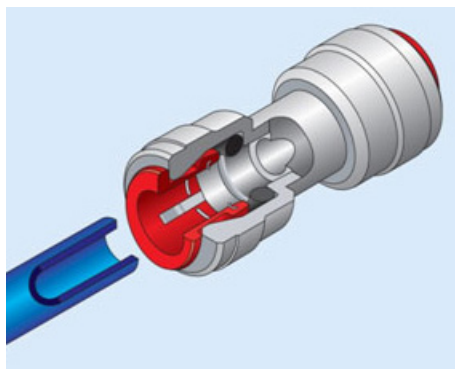

- When inserting the tube, remove any obstructions inside of the fitting before inserting the tube. Push the tube firmly into the quick connect fitting to ensure that the tube is fully connected and sealed. Inserting the tube into the fitting only takes moderate force.
- To avoid damage to the O-Ring, make sure burrs and sharp edges are removed from the cut end of the tube. The tube, O-Ring or fitting should not be scratched or damaged as this can cause water leaks later on.
- The collet clip (gripper) (see Step 4 drawing) has stainless steel teeth which permanently hold the tube firmly in position while the O-Ring provides a leak proof seal.
- For soft or thin walled plastic tube other than standard poly tube we recommend the use of a tube insert to prevent the tube from collapsing & leaking.

#### Step 3. Checking the Connection

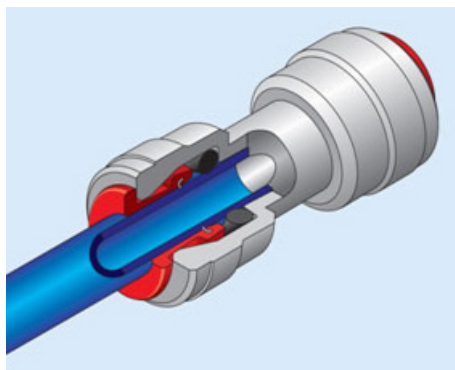

- To check that the fitting is properly connected to the tube, pull it moderately once. The tube should not be able to be pulled out of the fitting.

#### Step 4. Removing the Tube or Plug

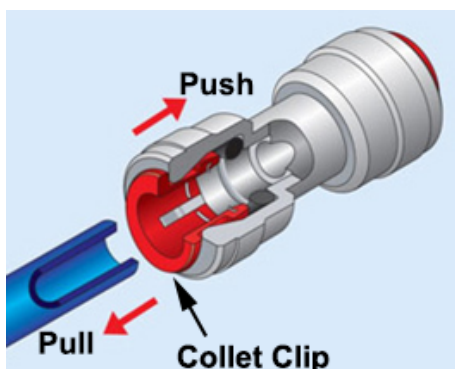

- Make sure to completely eliminate all pressure before removing the tube from the Quick Connector Union fitting.
- Turn off the incoming feed water and open the faucet.
- **When removing the tube or plugs, push and hold the collet clip in against the fitting as you pull the tube or plug out. This releases the tube or plug.**
- Fittings and tubes can be reused. Be sure to check for possible scratches on the tube when reusing.

8. PRIMARY COMPONENTS DIAGRAM

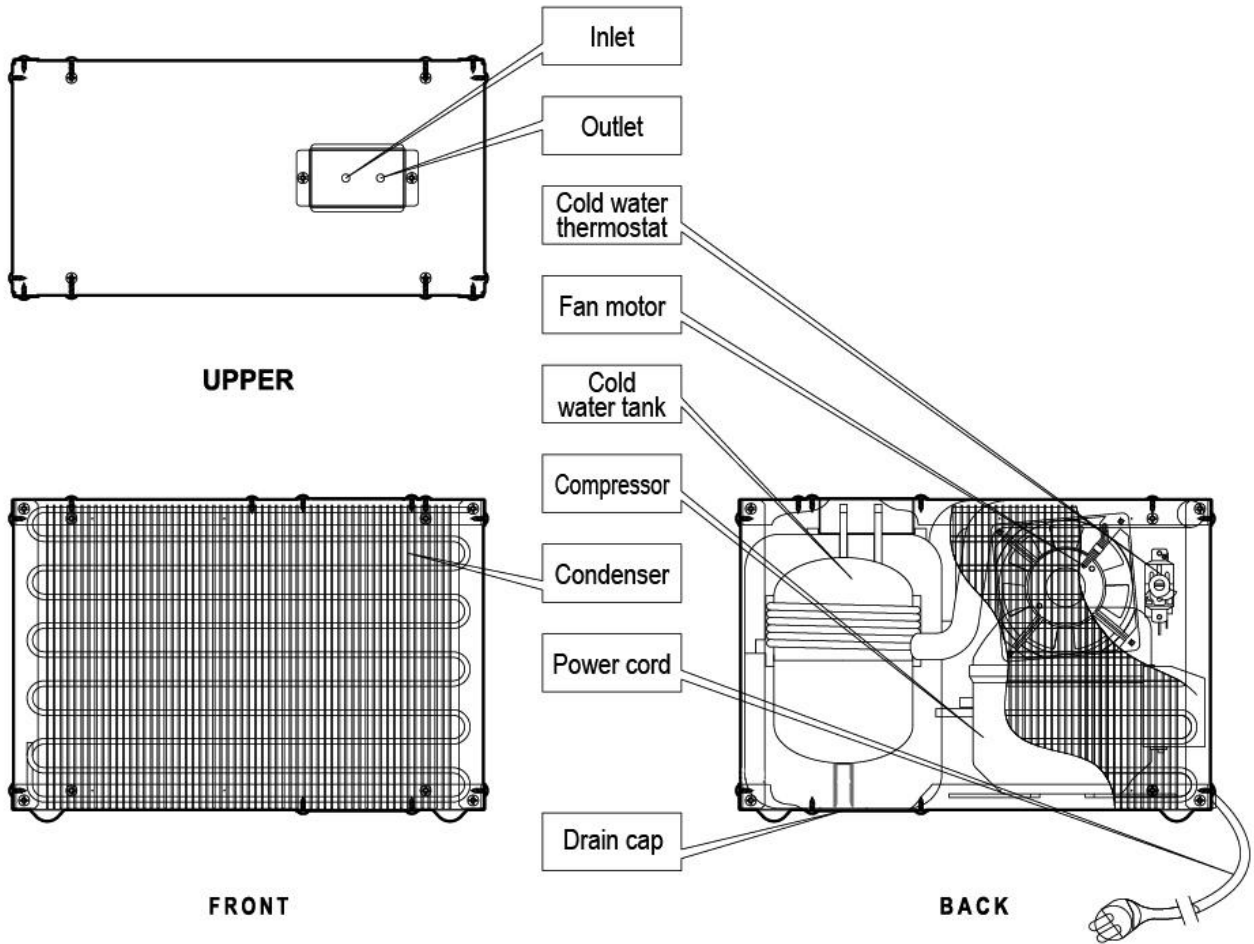

9. ADJUSTING THERMOSTAT

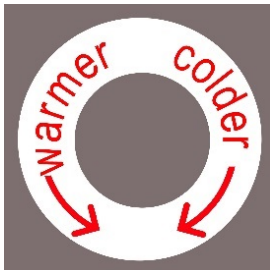

✓ The water temperature can be adjusted by turning the screw on the cold water thermostat as located in the diagram above. Use a small straight blade screw driver. Turn clockwise to make colder. Turn counterclockwise to make warmer. Do not force the turning pressure to the thermostat with the screwdriver, as excessive force can damage the thermostat. **Caution: Adjusting the thermostat should be performed by a professional. Adjusting the thermostat too cold may cause the Chiller to freeze up.**

10. SPECIFICATIONS

Model #:	CHL-501
Product Type:	Under Sink Water Chiller for Residential and Office Use
Product Dimensions:	L: 16" x W: 8" x H: 11.75" (406x203x300)
Product Weight:	23.75 lbs (10.8 KG)
Shipping Dimensions:	L: 20.87" x W: 13" x H: 15.35" (530x330x390)

Shipping Weight:	27.25lbs (12.5 KG)
Product Color:	Appliance Grade Designer Brushed Stainless Steel Cabinet
Application:	Chills Drinking Water for Residential and Office Use. Connects to RO Reverse Osmosis and Filtered Drinking Water Systems.
Warranty:	1-Year Non-Transferable Limited Manufacturer's Warranty *
Power:	110 Volts 60Hz 3 Prong Grounded Cord Attached 1.8A 140W - Motor-Compressor Thermally Protected
 Certifications:	Conforms to UL Standard 399. Certified to CSA Standard C22.2 #s 60335-2-24 & 60335-1
Refrigerant Type:	R-134a 54g (1.9oz) Environmentally Friendly
Inlet Pressure:	15~100psi (0.10~0.69MPa) Optional Pressure Limiter Available For Use If Installation is Not On a Reverse Osmosis RO System or Over 100 PSI. 30-50 psi (factory preset to 40 PSI) Pressure Limiter Allows Adjustable Flow Rate to the Faucet.
Cold Water Output:	1.34 Gallons Per Hour (5 Liters 5L/H (<10C) )
Tank:	SUS304 Stainless Steel 0.6 Gallon (2.3L)
Connections:	1/4" MNPT Stainless Steel Tube In & Out
Cold Water Thermostat Temperature Range:	42 - 54°F Adjustable Thermostat **
Shipping:	924 Per 40'HQ Container - 24 Per Pallet (40"x48"x76") Individually Prepackaged for Home Delivery Shipping.
UPC#:	850901003767

\*See separate warranty description for details.

\*\* Temperature range may be affected by proper ventilation to allow heat to vent away from the chiller.

{\*\*\*} Chiller Daddy® reserves the right to change specifications and design without notice.

**11. TROUBLESHOOTING GUIDE**

<b>TROUBLE</b>	<b>POSSIBLE CAUSE</b>	<b>REMEDY</b>
<b>REFRIGERATION SYSTEM</b>		
A. Compressor does not run.	No electric power to outlet.	Turn on electric power outlet.
	The thermostat is misadjusted or defective.	Adjust or replace the thermostat, as necessary.
	The line voltage is low.	Check the line voltage. It must be at least 90% of minimum voltage.
	The compressor is defective.	Replace the compressor.
B. Water is adequately chilled, but Chiller runs excessively or continuously.	Poor ventilation.	Minimum both sides clearance 5"
	The condensers are dirty or restricted.	Clean both condensers using a vacuum with brush attachment or relocate the unit to prevent restricting airflow across the condensers
	The thermostat is defective. (the contacts are shorted or the control is not adjusted properly)	Replace or adjust the thermostat as necessary.
	The ambient temperature is high.	It is normal for the Chiller to run continuously at high ambient temperatures.
C. Water is not cold but the Chiller compressor runs continuously.	There has been a substantial loss in the sealed system's charge of refrigerant.	If refrigerant leak is suspected, return Chiller to authorized service center or factory for repair.
	The compressor is defective.	Same as above.
D. Water is not cold enough but the Chiller runs excessively.	The condensers are dirty or restricted.	Clean the condensers with vacuum and brush attachment. Confirm location to allow air flow across the condensers.
	The cold water thermostat is set high or the Chiller is in a high ambient environment.	Check the thermostat setting and adjust as necessary. Lower the ambient temperature.
	Usage of the cold water system is greater than the Chiller capacity.	Inform the users of the cold water system's maximum capacity.
	The temperature of the supply water is too high.	Wait for a moment until cold water is made.
	The refrigeration system is overcharged or undercharged.	Return Chiller to authorized service center for refrigerant recharge or factory for repair.
	There is a partial restriction in the refrigeration system.	
E. The Chiller has a short running cycle. It is cooling, but does not run long enough to cool water to the required level.	Check wattage. If wattage readings are normal, the thermostat may be defective.	Replace the thermostat.
	The thermostat is improperly set for the prevailing environmental conditions and Chiller usage.	Adjust the thermostat.
	The compressor motor is defective, causing the Chiller to cycle on the overload protector.	Return Chiller to authorized service center or factory for repair.
F. The cold water flows slowly or not at all.	The cold water thermostat is too low, causing ice to build up in the reservoir, blocking water flow.	Defrost Chiller. Adjust the thermostat to a warmer temperature.
<b>NOISE</b>		
A. There is excessive noise coming from the Chiller, but it is otherwise operating normally.	The Chiller is not level.	The Chiller must be leveled and on an even surface. All 4 feet must be firmly touching the surface.
	A section of the tubing connecting the Chiller is touching other parts of the Chiller, other plumbing or cabinet wall, causing noise to be generated due to vibration.	Adjust position of the tubing to make sure it is not in contact with any other parts or surfaces.

	Check the connection of the fixed screws.	Tighten any loose screws.
<b>WATER LEAKAGE</b>		
A. Leakage from inside of Chiller	The cold water tank leaks.	Return Chiller to authorized service center or factory for repair.
<b>OTHER</b>		
A. Odd taste and smell in the water	Mineral concentration of supplied water is somewhat high.	This product does not include filters. Change the existing filter or use a proper one.
	Not used for a long time.	Continue to let the water flow until it runs clear. Sanitize as instructed in Section 5 of this manual.
B. Strong water flow	Supplied water pressure is too high.	Install a pressure limiter that can control the pressure or contact a qualified plumber.

## 12. WARRANTY & SERVICE

**Do not return this product to the store for warranty claims: Please Contact Customer Support at [info@chillerdaddy.com](mailto:info@chillerdaddy.com)**

### Non-Transferable Limited Warranty

\* Chiller Daddy LLC ("Chiller Daddy") warrants this water chiller, to the original purchaser, and to no other person, to be free from manufacturer's defects in workmanship or material under normal operating conditions for (1) year from the original date of purchase. Chiller Daddy LLC may require proof of date of purchase from an authorized dealer and/or accompanying serial number. Please retain your receipt or invoice as proof of purchase date and location. This warranty applies only in the country in which the unit was originally sold. This Limited Warranty does not cover failure due to improper installation, improper maintenance or service (by you or a third party), misuse, abuse, accident, commercial use, or failure to perform routine maintenance on the water chiller as outlined in the User's Manual. This Limited warranty shall not apply to the following:

- Products that are used outside of office or residential environments
- Use where water is microbiologically unsafe or of unknown quality
- Failure caused by accident, fire, floods, or acts of God
- Service to the unit by unauthorized personnel
- Issues caused by the facilities electrical system, i.e. circuit breakers and fuses, power surges or fluctuations etc.
- Any damage to finishes, dents, scratches, rust or discoloration

The limited warranty is void if the water chiller is modified or altered. Alteration may cause serious flooding, electrical shock or a fire. The limited warranty is void if the PSI of the incoming location exceeds 100 PSI and an approved pressure limiter was not installed. For all office or residential settings not using an RO reverse Osmosis system with a holding tank, a water pressure limiter must be installed. If the water pressure at the location occasionally or constantly exceeds 100 PSI, a water pressure regulator must be professionally installed, or the warranty is void. The Warranty shall be limited to repair or replacement of parts of the Chiller, whichever Chiller Daddy shall determine necessary, using reasonable discretion, upon examination. Please contact customer service for instructions. If Chiller Daddy LLC confirms, after examination, a defect covered by this limited warranty and if Chiller Daddy approves the claim, then Chiller Daddy will replace the defective part without charge. The warranty does not cover any freight costs to our facility; Chiller Daddy will return replacement parts, postage prepaid. Unless required by law, Chiller Daddy LLC makes no other warranty, agreement, or guarantee, express, implied or statutory including implied warranty of merchantability or fitness for a particular purpose. Further, Chiller Daddy shall have no liability to purchaser or a third party for special, indirect, punitive, incidental, or consequential damages. If anything here is unclear, please contact customer support for further information.