



***PLATINUM***  
***PRO PLUG-IN***  
***HONDA CIVIC (EP3)***  
***2002-2005***  
***(HT055047)***  
**QUICK START GUIDE**



## LIMITED WARRANTY

Lockin Pty Ltd trading as Haltech warrants the Haltech™ Programmable Fuel Injection System to be free from defects in material or workmanship for a period of **12 months** from the date of purchase.

Proof of purchase, in the form of a bill of sale or receipted invoice, which indicates that the product is within the warranty period, must be presented to obtain warranty service. Lockin Pty Ltd trading as Haltech suggests that the purchaser retain the dealer's dated bill of sale as evidence of the date of retail purchase.

If the Haltech™ Programmable Fuel Injection System is found to be defective as mentioned above, it will be replaced or repaired if returned prepaid along with proof of purchase. This shall constitute the sole liability of Lockin Pty Ltd trading as Haltech.

To the extent permitted by law, the foregoing is exclusive and in lieu of all other warranties or representations, either expressed or implied, including any implied warranty of merchantability or fitness. In no event shall Lockin Pty Ltd trading as Haltech, be liable for special or consequential damages.

## DISCLAIMER

Haltech will not be held responsible for any damage caused by the incorrect installation or tuning of this product. It is the installers responsibility to ensure the wiring connections and pinouts match that of the vehicle the unit is being installed into.

Haltech has taken all care to make sure the connections match the specified vehicles listed, but variations in wiring and connections on vehicles can occur and therefore this should be checked BEFORE the unit is installed.

Haltech highly recommends installation and tuning of this product is to be carried out by a professional, with an understanding on installing and tuning engine management systems. Misuse of this product can destroy your engine.

## WARNING

This ECU is designed and sold for Racing use only. Using this product for street / road use may be prohibited by law. Please check with your local vehicle authority before using this product.

## GENERAL INSTALLATION WARNING

Avoid open sparks, flames or operation of electrical devices near flammable substances. Always disconnect the battery cables when doing electrical work on your vehicle.

Do not charge the battery with a 24 Volt truck charger or reverse the polarity of the battery or any charging unit. Do not charge the battery with the engine running as this could expose the ECU to an unregulated power supply that could destroy the ECU and other electrical equipment.

All fuel system components and wiring should be mounted away from heat sources, shielded if necessary and well ventilated. Disconnect the Haltech ECU from the electrical system whenever doing any arc welding on the vehicle by unplugging the wiring harness connector from the ECU.

After completing the installation, make sure that there are no fuel leaks, and no wiring left un-insulated in case a spark or short-circuit occurs and causes a fire. Also make sure that you follow all proper workshop safety procedures. If you're working underneath a jacked-up car, always use safety stands!

# PLATINUM Pro Plugin Honda Civic (EP3) Quick Start Guide

Congratulations on purchasing a Haltech Engine Management System.

This *fully programmable Plug and Play* product opens the door to virtually limitless performance modification and tuning of your vehicle. Programmable systems allow you to extract all the performance from your engine by delivering precisely the required amount of fuel and ignition timing that your engine requires for maximum output under all operating conditions.

This quick start guide will walk you through installation of the Platinum Pro ECU into a vehicle. This guide is accompanied by the full service manual located on the software CD provided with the ECU that you or your tuner will need to refer to before completing your installation and configuration. The Manual can also be downloaded from the Haltech website [www.haltech.com](http://www.haltech.com)

## Supported Vehicles

The Platinum Pro Plug-in Honda Civic (EP3) ECU supports the following vehicles:

Honda Civic (EP3) Type R / Type S / Si (2002-2005)  
Honda Integra DC5 / Acura RSX (2002 - 2004)

## Platinum Pro Plug-in Honda Civic (EP3) Kit Includes

- Haltech Platinum Pro Plug-in ECU
- USB Cable
- Software CD
- Quick Start Guide
- Haltech Sticker

## *Optional Accessories ( Sold Separately )*

- Rear Auxiliary Harness ( HT040003 )
- Platinum Series Mounting Kit (HT039000)

## **Loaded Basemap**

Your Platinum Pro Plugin has been programmed with a basemap to suit a Honda Civic Type R with a K20A standard engine using the factory Honda MAP Sensor.

Please ensure you load, modify and check the corresponding basemap for your application before attempting to start the vehicle.

## ECU Installation

To install your new Platinum Pro Plug-in to your Honda Civic, please follow the procedures below.

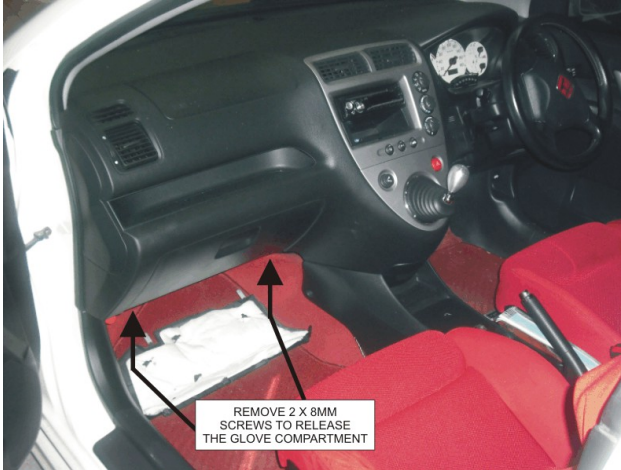
\* Please Note the following Installation photos based on a Honda Civic Type R (EP3)  
You will require the following tools

- Socket set with 8mm and 10mm sockets
  - Platinum Mounting Kit (HT039000) or Cable Ties / 3M Velcro tape or similar
1. Locate your factory ECU. This will be located on the passenger side of the vehicle behind the glove compartment.



**Figure 1 – ECU Location**

2. Remove the cover under the glove compartment by gently pulling it downwards towards the floor. Your factory ECU connectors should now be visible. Proceed to remove the glove compartment by un-screwing the two 8mm screws holding it in place. Once un-done the glove compartment can be removed and the factory ECU can be accessed.



**Figure 2 – Factory ECU location with cover removed**

3. With the ignition turned off disconnect the 3 connectors from the front of the ECU. Remove the 3 x 10mm bolts securing the ECU in place. Once these bolts have been taken out, remove the factory ECU from the vehicle.



**Figure 3 – Factory ECU removed**

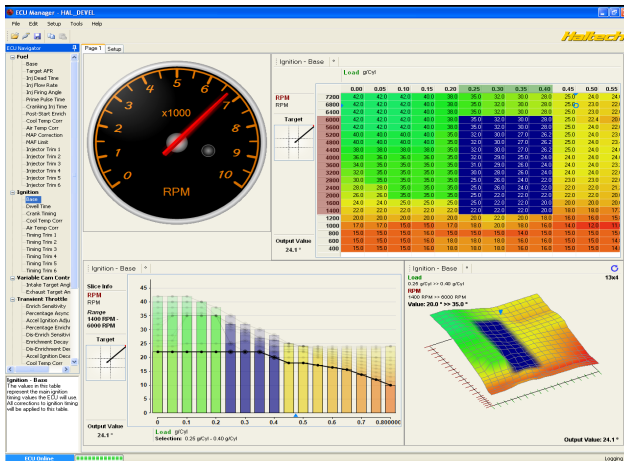
4. With the factory ECU removed, install the Haltech Plug-in ECU. Plug the 3 connectors into their respective locations on the front of the ECU. The optional auxiliary harness can be installed at this point if required. Mount the ECU to the factory cradle by means of the Haltech Platinum Mounting kit or Cable ties and Velcro Tape.



***Figure 4 – Haltech ECU Mounted in factory location***

5. With the Haltech ECU installed do not attempt to start the vehicle. You will need to configure the ECU. The Haltech ECU is Pre Configured for use with a K20A standard engine. If this is your setup then you will not have to load a basemap. However, it is still strongly recommended that you check your settings before starting your engine. If another engine or sensor combination is to be used please go online with the ECU using the supplied ECU Manager software and load the basemap which is specific to your model.  
With the corresponding basemap loaded into the ECU, a standard engine should be able to be started at this point, but it is recommended that you check all settings in the basemap before attempting to start the engine. If your engine is not standard please adjust any configuration settings affected according to your setup.

- With the engine started and running its time to tune. This is best achieved by your nearest engine tuner. See the listing of Haltech dealers on our website to find the one closest to you. Go to [www.haltech.com](http://www.haltech.com)



**Figure 5 – Haltech ECU Manager Software tuning page**

- Re-install the Glove compartment and lower cover to the vehicle.



**Figure 6 – Glove compartment and lower cover Re-installed**

## ***ECU Manager Software***

ECU Manager software is used for setup, calibration and diagnostics and can be found on the CD supplied with this unit or downloaded from the Haltech website [www.haltech.com](http://www.haltech.com)

### ***Minimum System Requirements***

Operating System:	Windows 2000 SP4 / XP / Vista / Windows 7
Processor Speed:	1GHz
RAM:	256 Mb
Video Card:	128MB graphics card with 3D acceleration
USB:	1.1
Hard Drive Space:	250Mb
Minimum Screen Resolution:	1024 x 768 pixels

### ***Installing ECU Manager***

Installing ECU Manager onto your PC is performed similar to any other Windows software package. Installation is outlined below to ensure correct installation:

- 1.** Insert the CD-ROM into your PC's CD-ROM drive. The CD should automatically launch into the Haltech Browser. If the CD does not run automatically double click on the "My Computer" icon on the desktop, double click on the Haltech icon (CD- ROM drive) to start the browser software.
- 2.** The Browser will display the disclaimer and you will need to agree to the terms stated before allowing to progress. Read the Disclaimer and click on AGREE if you agree.
- 3.** Now you will be able to access all the information contained on the CD
- 4.** To download the Platinum Software, click on the Platinum Series ECU Manager Link. You will be prompted to install the software. Click "Install" to install ECU Manager and the Data Log viewer.
- 5.** Follow the software prompts and install the software.

With your programming cable (USB) attached to your ECU and the other end connected to your laptop, power up the ECU by turning your key to IGN. Start the programming software on your PC and go online with the ECU.



## ***ECU Manager / ECU Manuals***

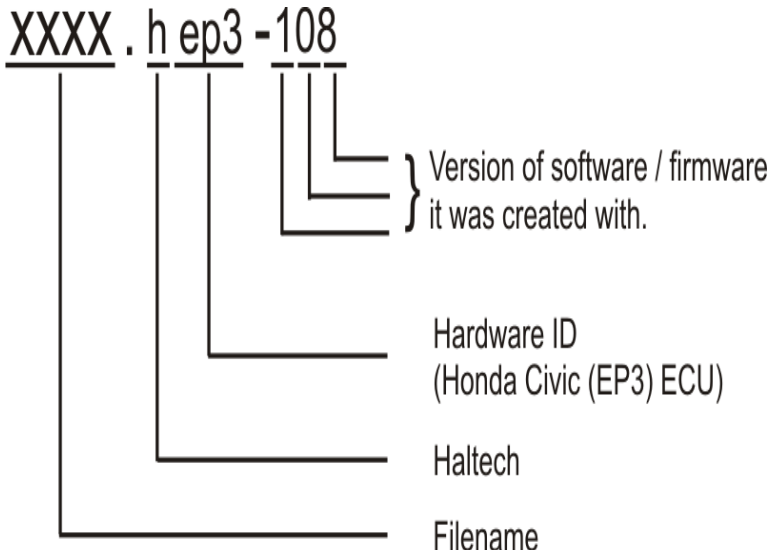
Detailed manuals can be found in the software by pressing your F1 key or by selecting the Help tab located at the top left of the screen

### ***ECU Manager File Extensions***

When ECU manager saves the map from the Haltech ECU, it saves the map with a Haltech specific file extension.

The File extension can be broken down as follows:

*Example File : xxxx.hep3-108*



Later map versions cannot be loaded into ECU's with earlier firmware versions.

ECU Manager will upgrade earlier map versions when loading into ECU's with later firmware versions.

ECU Manager upgrades maps between versions where equivalent settings are available. However, new settings not in the original map, will be substituted with values from the new version's default map.

**WHENEVER ECU MANAGER CONVERTS YOUR ECU MAP, YOU SHOULD ALWAYS CHECK YOUR MAP SETTINGS TO ENSURE THAT ALL THE APPROPRIATE SETTINGS HAVE BEEN CONVERTED CORRECTLY.**

## **Rear Auxiliary Connector**

The Platinum Pro Plugin Series allows further expansion of your ECU by the Rear Auxiliary Connector.

The Rear Auxiliary connector allows you access to:

- 2 Additional Digital Pulsed Outputs ( DPO )
- 2 Additional Digital Switched Outputs ( DSO )
- 2 Additional Analogue Voltage Inputs ( AVI )
- 2 Additional Analogue Temperature Inputs ( ATI )

These extra Inputs / Outputs can be used to:

- Fit additional sensors. (eg MAP and Temperature)
- Control additional devices via relays
- Control additional solenoids directly (eg Aftermarket Boost Control solenoid)

The Rear Auxiliary harness is available as an optional extra. ( HT040003 )



<b>Pin #</b>	<b>Wire Colour</b>	<b>Connection</b>
1	O	+5V
2	Y	AVI1 (MAP)
3	O/B	AVI2
4	B/W	SIGNAL GROUND
5	V/B	DPO1
6	V/BR	DPO2
7	-	-
8	-	-
9	O	+5V
10	GY	ATI1 (AIR)
11	GY/B	ATI2
12	B/W	SIGNAL GROUND
13	V/R	DSO1
14	V/O	DSO2
15	-	-
16	-	-

**Figure 7 - Rear Auxiliary Harness Connector and Pinout**

### ***Digital Pulsed Outputs ( DPO )***

Digital Pulsed Outputs are capable of producing pulsed waveforms with varying duty and frequency. DPO's can be used to control various devices such as thermo-fans, shift lights, bypass air control valves, boost control solenoids etc.

When a Digital Pulsed output is activated by the ECU the output will switch to ground. Solenoid valves and shift lights etc can be run directly from the output, however high current devices such as thermo-fans and additional fuel pumps must be activated through a relay. This way the DPO is only switching a relay and not a high current draw device.

Two additional outputs can be connected using the Optional Rear Auxiliary Harness ( HT040003 )

**Digital Pulsed Outputs are limited to 800mA Max current draw.**

### ***Digital Switched Outputs ( DSO )***

Digital Switched Outputs are capable of switching to ground  
DSO's can be used to control relays in an on / off state only.

Two additional outputs can be connected using the Optional Rear Auxiliary Harness ( HT040003 )

**Digital Switched Outputs are limited to 800mA Max current draw.**

### ***Analogue Voltage Inputs ( AVI )***

Analogue Voltage Inputs accept variable voltage inputs from 0V to 5V. These inputs can also accept switch inputs that change between two different voltage levels. The On Voltage and Off Voltage define what the thresholds are between the On and Off states. The Voltage can be viewed as a channel in the software to determine the thresholds for a switched input.

Two additional sensors or switched inputs can be connected using the Optional Rear Auxiliary Harness ( HT040003 )

### ***Analogue Temperature Inputs ( ATI )***

Analogue Temperature Inputs accept variable resistance sensors.

These inputs have a pull – up resistor connected to them to allow them to be used with most automotive temperature senders ( Variable resistance thermistor types ).

Two additional sensors can be connected using the Optional Rear Auxiliary Harness ( HT040003 )

### ***Wire connections***

When using crimp connectors ensure that the correct crimping tool is used – if in doubt do a pull test on a crimp connector, the wire should break before the wire pulls out of the crimp. Terminal soldering can weaken a connection and should only be used as a last resort. If solder joints are used, ensure joints are well isolated from movement as solder joints are prone to fracture.

When splicing 2 wires it is preferable to use a crimp splice – again if using a solder joint, ensure joint is limited in its range of possible movement as solder joints are prone to fracture. Always use heat-shrink sleeving to insulate wires.

## The Haltech CAN Network

The Haltech CAN network allows for simple and effective expansion in ECU capability and functionality without having to go to the trouble of wiring in a whole new computer.

Expansion is made possible by the addition of multiple expansion devices that communicate to the main ECU via a Control Area Network (CAN).

Installation time and costs are kept to a minimum as all expansion devices are powered up from the main ECU via the pre-terminated connection cable that comes with each expansion device.

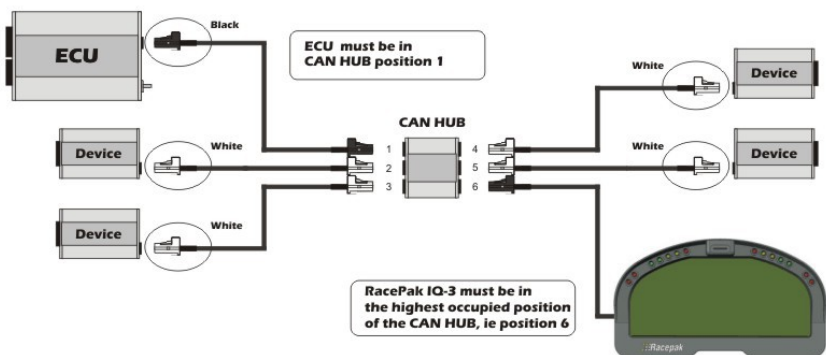
Simply connect the device directly to the 8 pin CAN connector on the rear of the ECU or connect using an optional Haltech CAN Hub (order as part # HT0599910) if multiple expansion devices are required).

Each expansion device is pre-programmed with a unique ID code which allows it to be recognised on the network and work correctly first time every time.

For current available expansion devices please go to our website at [www.haltech.com](http://www.haltech.com)

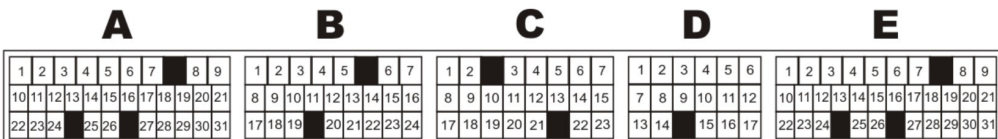


**Figure 8 – Haltech ECU connected to a Racepak Dash**



**Figure 9 – Haltech ECU connected to 5 Auxiliary CAN based devices**

# ECU Pinout



## LOOKING INTO ECU CONNECTOR

A1	-
A2	IGP2 (Power Source)
A3	IGP1 (Power Source)
A4	PG2 (Power Ground)
A5	PG1 (Power Ground)
A6	-
A7	CKP (Crankshaft Position Sensor)
A8	Intake Manifold Runner Control Valve Position Sensor * K20A3 engine
A9	KS (Knock Sensor)
A10	SG2 (Sensor Ground)
A11	SG1 (Sensor Ground)
A12	IACV (Idle Air Control Valve)
A13	-
A14	-
A15	TPS (Throttle Position Sensor)
A16	-
A17	-
A18	VSS (Vehicle Speed Sensor)
A19	MAP (Manifold Absolute Pressure Sensor)
A20	VCC2 (Sensor Voltage)
A21	VCC1 (Sensor Voltage)
A22	-
A23	LG2 (Logic Ground)
A24	LG1 (Logic Ground)
A25	CMPA (Camschaft Position Sensor)
A26	TDC / CMPB (Top Dead Centre Sensor)
A27	IGLS4 (No. 4 Ignition Coil Pulse)
A28	IGLS3 (No. 3 Ignition Coil Pulse)
A29	IGLS2 (No. 2 Ignition Coil Pulse)
A30	IGLS1 (No. 1 Ignition Coil Pulse)
A31	-

B1	VTC + (VTC Oil Control Solenoid valve + Side)
B2	INJ4 (No.4 Injector)
B3	INJ3 (No.3 Injector)
B4	INJ2 (No.2 Injector)
B5	INJ1 (No.1 Injector)
B6	FANC (Radiator Fan Control)
B7	RVS (Reverse Lock Solenoid Valve) *K20A2 Engine
B8	ECT (Engine Coolant Temperature Sensor)
B9	VTPSW (Vtec Oil Pressure Switch)
B10	ALT (Alternator L Signal)
B11	-
B12	-
B13	ALTF (Alternator FR Signal)
B14	-
B15	VTS + (VTEC Solenoid Valve)
B16	-
B17	IAT (Intake Temperature Sensor)
B18	ALTC (Alternator Control)
B19	-
B20	-
B21	PCS (Evaporative Emission Canister Purge Valve)
B22	IMRC (Intake Manifold Runner Control Solenoid Valve)
B23	VTC - (VTC Oil Control Solenoid Valve - Side)
B24	-

## CONNECTORS C AND D ARE NOT USED

E1	IMO FPR (Immobilizer Fuel Pump Relay)
E2	SHO2S (Secondary Heated Oxygen Sensor (Secondary HO2S) Sensor 2)
E3	LG3 (Logic Ground)
E4	SG3 (Sensor Ground)
E5	VCC3 (Sensor Voltage)
E6	SHO2SHTC (Secondary Heated Oxygen Sensor (Secondary HO2S) Heater Control)
E7	MRLY (PGM-FI Main Relay)
E8	PQ2SHTCR (Air Fuel Ratio Sensor Heater Control Relay)
E9	IG1 (Ignition Signal)
E10	IMO FPR (Immobilizer Fuel Pump Relay) (Internally linked to E1)
E11	-
E12	-
E13	-
E14	FTP (Fuel Tank Pressure (FTP) Sensor)
E15	ELD (Electrical Load Detector)
E16	PSPSW (Power Steering Pressure Switch Signal)
E17	-
E18	ACC (AC Clutch Relay)
E19	-
E20	2WBS (Evaporative emission (EVAP) Bypass Solenoid Valve)
E21	VSV (Evaporative emission (EVAP) Canister Vent Shut Valve)
E22	BKSW (Brake Pedal Position Switch)
E23	K-Line
E24	SEFMJ (Multiplex Control Unit Communications)
E25	VSSOUT (Vehicle Speed Sensor Output Signal)
E26	NEP (Engine Speed Pulse)
E27	IMOCO (Immobilizer Code)
E28	-
E29	SCS (Service Check Signal)
E30	-
E31	ML (Malfunction Indicator Lamp)

Figure 10 – Platinum Pro Plug-in Honda Civic EP3 ECU Pinout



# ***Haltech***™

ENGINE MANAGEMENT SYSTEMS



**HALTECH HEAD OFFICE:**    PH:    +612 9729 0999  
  FAX:    +612 9729 0900  
  EMAIL: [sales@haltech.com](mailto:sales@haltech.com)

**HALTECH US OFFICE:**            EMAIL: [usa@haltech.com](mailto:usa@haltech.com)

**See the Haltech Website for your local authorized dealer.**

**[www.haltech.com](http://www.haltech.com)**

**Version 6**