



***PLATINUM***

***PRO PLUG-IN***

***Nissan Skyline R34 GT-t  
(HT055105)***

**QUICK START GUIDE**



## LIMITED WARRANTY

Lockin Pty Ltd trading as Haltech warrants the Haltech™ Programmable Fuel Injection System to be free from defects in material or workmanship for a period of **12 months** from the date of purchase.

Proof of purchase, in the form of a bill of sale or receipted invoice, which indicates that the product is within the warranty period, must be presented to obtain warranty service. Lockin Pty Ltd trading as Haltech suggests that the purchaser retain the dealer's dated bill of sale as evidence of the date of retail purchase.

If the Haltech™ Programmable Fuel Injection System is found to be defective as mentioned above, it will be replaced or repaired if returned prepaid along with proof of purchase. This shall constitute the sole liability of Lockin Pty Ltd trading as Haltech.

To the extent permitted by law, the foregoing is exclusive and in lieu of all other warranties or representations, either expressed or implied, including any implied warranty of merchantability or fitness. In no event shall Lockin Pty Ltd trading as Haltech, be liable for special or consequential damages.

## DISCLAIMER

Haltech will not be held responsible for any damage caused by the incorrect installation or tuning of this product. It is the installers responsibility to ensure the wiring connections and pinouts match that of the vehicle the unit is being installed into.

Haltech has taken all care to make sure the connections match the specified vehicles listed, but variations in wiring and connections on vehicles can occur and therefore this should be checked BEFORE the unit is installed.

Haltech highly recommends installation and tuning of this product is to be carried out by a professional, with an understanding on installing and tuning engine management systems.

Misuse of this product can destroy your engine.

## WARNING

This ECU is designed and sold for Racing use only. Using this product for street / road use may be prohibited by law. Please check with your local vehicle authority before using this product.

## GENERAL INSTALLATION WARNING

Avoid open sparks, flames or operation of electrical devices near flammable substances. Always disconnect the battery cables when doing electrical work on your vehicle.

Do not charge the battery with a 24 Volt truck charger or reverse the polarity of the battery or any charging unit. Do not charge the battery with the engine running as this could expose the ECU to an unregulated power supply that could destroy the ECU and other electrical equipment.

All fuel system components and wiring should be mounted away from heat sources, shielded if necessary and well ventilated. Disconnect the Haltech ECU from the electrical system whenever doing any arc welding on the vehicle by unplugging the wiring harness connector from the ECU.

After completing the installation, make sure that there are no fuel leaks, and no wiring left un-insulated in case a spark or short-circuit occurs and causes a fire. Also make sure that you follow all proper workshop safety procedures. If you're working underneath a jacked-up car, always use safety stands!

# ***PLATINUM Pro Plug-in Nissan Skyline R34 GT-t*** **Quick Start Guide**

Congratulations on purchasing a Haltech Engine Management System.

This *fully programmable Plug and Play* product opens the door to virtually limitless performance modification and tuning of your vehicle. Programmable systems allow you to extract all the performance from your engine by delivering precisely the required amount of fuel and ignition timing that your engine requires for maximum output under all operating conditions.

This quick start guide will walk you through installation of the Platinum Pro ECU into a vehicle. This guide is accompanied by the full service manual located on the software CD provided with the ECU that you or your tuner will need to refer to before completing your installation and configuration. The Manual can also be downloaded from the Haltech website [www.haltech.com](http://www.haltech.com)

## **Supported Vehicles**

The Platinum Pro Plug-in Nissan Skyline R34 GT-t ECU supports the following:

Nissan Skyline R34 GT-t – RB25DET, RB25DE, RB20DE (manual transmission only)  
*(R34 GT-t Traction Control currently not supported, TCS Warning lights will illuminate)*

Nissan Stagea WC34 Series – RB25DET (manual transmission only)

## **Platinum Pro Plug-in Nissan Skyline R34 GT-t Kit Includes**

- Haltech Platinum Pro Plug-in ECU
- USB Cable
- Software CD
- Quick Start Guide

## ***Optional Accessories ( Sold Separately )***

- Rear Auxiliary Harness ( HT040003 )
- 3 Bar Map Sensor ( HT010104 )
- Air Temperature Sensor ( HT010200 )

## ***Loaded Basemap***

Your Platinum Pro Plug-in has been programmed with a basemap to suit a Nissan R34 GT-t running a RB25DET engine using the standard MAF sensor.

Please ensure you load, modify and check the corresponding basemap for your application before attempting to start the vehicle

## ECU Installation

To install your new Platinum Pro Plug-in to your Nissan Skyline R34 GT-t, please follow the procedures below.

You will require the following tools

- Screwdrivers Phillips No 1 & No 2 , Small Flat
- Socket set with 10mm socket
- Cable Ties / 3M Velcro tape or similar

1. Locate your factory ECU. This will be located on the left hand side A pillar, behind the kick panel. Remove the kick panel to access the ECU.



***Figure 1 – Left hand side kick panel showing ECU Location***

2. With the ignition turned off remove the ECU connector from the ECU by unscrewing the bolt in the centre of the connector using a 10mm socket and gently easing the connector out. Be sure to pull the connector out squarely so not to cause any damage to the pins or wires. With the connector removed proceed with un-mounting the Factory ECU from the A pillar by removing the 2 bolts securing it.



**Figure 2 – Factory ECU disconnected and removed**

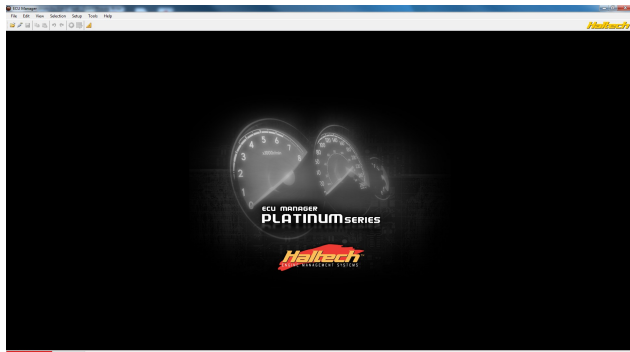
3. Connect the Platinum Pro Plug-in ECU to the factory harness. Once again be careful that the connector enters squarely so as not to damage any pins. Tighten the header bolt while pressing the sides of the connector into the ECU. At this time you can connect the optional auxiliary harness if you want to install optional sensors / relays / or solenoids. Refer to the rear auxiliary harness section for more information.



**Figure 3 – Platinum Pro Plug-in ECU Connected**

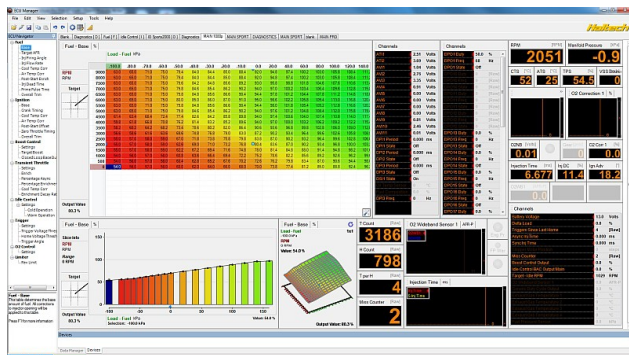
- With the ECU installed do not attempt to start the vehicle. You will need to configure the ECU. The ECU is pre-configured for use with a RB25DET standard engine using the standard MAF sensor. If this is your setup then you will not have to load a basemap. However, it is still strongly recommended that you check your settings before basing your engine.

If another engine or sensor combination is to be used please go online with the ECU using the supplied ECU Manager software and load an appropriate map for your vehicle, or adjust your settings and maps to suit your vehicle. If your selected setup requires a MAP sensor, then connect and configure the internal or external MAP sensor. With the ECU configured for your vehicle, the engine should be able to be started at this point.



**Figure 4 – Haltech ECU Manager Software**

- With the engine started and running its time to tune. This is best achieved by your nearest engine tuner. See the listing of Haltech dealers on our website to find the one closest to you. Once the unit has been tuned, proceed to mount the unit in the factory location.



**Figure 5 – Haltech ECU Manager Software tuning page**

6. Mount the unit using cable ties and 3M Velcro tape or similar.  
Once the unit is securely mounted on the A pillar you can now proceed to re-install the kick panel.



***Figure 6 – Kick panel Re-installed***

## ***ECU Manager Software***

ECU Manager software is used for setup, calibration and diagnostics and can be found on the CD supplied with this unit or downloaded from the Haltech website [www.haltech.com](http://www.haltech.com)

### ***Minimum System Requirements***

Operating System:	Windows 2000 SP4 / XP / Vista / Windows 7
Processor Speed:	1GHz
RAM:	256 Mb
Video Card:	128MB graphics card with 3D acceleration
USB:	1.1
Hard Drive Space:	250Mb
Minimum Screen Resolution:	1024 x 768 pixels

### ***Installing ECU Manager***

Installing ECU Manager onto your PC is performed similar to any other Windows software package. Installation is outlined below to ensure correct installation:

- 1.** Insert the CD-ROM into your PC's CD-ROM drive. The CD should automatically launch into the Haltech Browser. If the CD does not run automatically double click on the "My Computer" icon on the desktop, double click on the Haltech icon (CD- ROM drive) to start the browser software.
- 2.** The Browser will display the disclaimer and you will need to agree to the terms stated before allowing to progress. Read the Disclaimer and click on AGREE if you agree.
- 3.** Now you will be able to access all the information contained on the CD
- 4.** To download the Platinum Software, click on the Platinum Series ECU Manager Link. You will be prompted to install the software. Click "Install" to install ECU Manager and the Data Log viewer.
- 5.** Follow the software prompts and install the software.

With your programming cable (USB) attached to your ECU and the other end connected to your laptop, power up the ECU by turning your key to IGN. Start the programming software on your PC and go online with the ECU.



## ***ECU Manager / ECU Manuals***

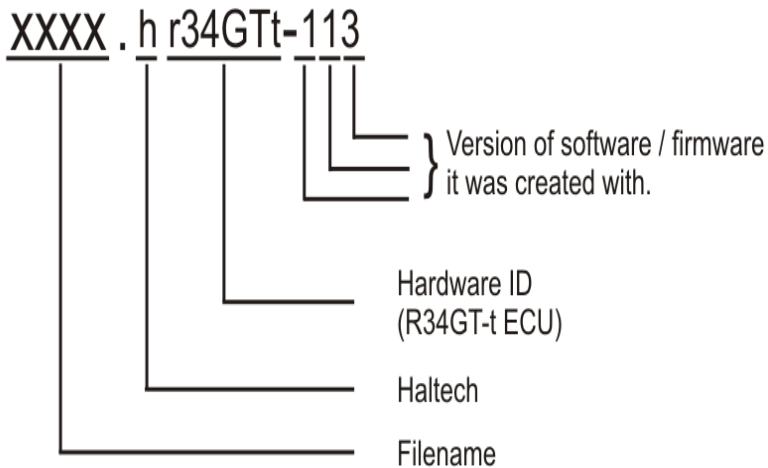
Detailed manuals can be found in the software by pressing your F1 key or by selecting the Help tab located at the top left of the screen

### ***ECU Manager File Extensions***

When ECU manager saves the map from the Haltech ECU, it saves the map with a Haltech specific file extension.

The File extension can be broken down as follows:

*Example File : xxxx.hr34GTt-113*



Later map versions cannot be loaded into ECU's with earlier firmware versions.

ECU Manager will upgrade earlier map versions when loading into ECU's with later firmware versions.

ECU Manager upgrades maps between versions where equivalent settings are available. However, new settings not in the original map, will be substituted with values from the new version's default map.

**WHENEVER ECU MANAGER CONVERTS YOUR ECU MAP, YOU SHOULD ALWAYS CHECK YOUR MAP SETTINGS TO ENSURE THAT ALL THE APPROPRIATE SETTINGS HAVE BEEN CONVERTED CORRECTLY.**

## Rear Auxiliary Connector

The Platinum Pro Plugin Series allows further expansion of your ECU by the Rear Auxiliary Connector.

The Rear Auxiliary connector allows you access to:

- 1 Additional Digital Pulsed Input ( DPI )
- 2 Additional Digital Pulsed Outputs ( DPO )
- 2 Additional Digital Switched Outputs ( DSO )
- 4 Additional Analogue Voltage Inputs ( AVI )
- 2 Additional +13.8V Sensor Power Outputs (**Limited to 500mA Per output pin**)
- 2 Additional +5V Sensor Power Output (**Limited to 50mA Per output pin**)
- 2 Signal Grounds

These extra Inputs / Outputs can be used to:

- Fit additional sensors. (eg MAP, Temperature and Flex Fuel )
- Control additional devices via relays
- Control additional solenoids directly (eg Aftermarket Boost Control solenoid)

*The Rear Auxiliary harness is available as an optional extra. ( HT040003 )*



Pin #	Wire Colour	Connection
1	O	+5V (50mA Max)
2	Y	AVI1 (MAP)
3	O/B	AVI2
4	B/W	SIGNAL GROUND
5	V/B	DPO1
6	V/BR	DPO2
7	GY<SHD>	DPI1
8	R	+13.8V (500mA Max)
9	O	+5V (50mA Max)
10	GY	AVI 3
11	GY/B	AVI 4
12	B/W	SIGNAL GROUND
13	V/R	DSO1
14	V/O	DSO2
15	-	-
16	R	+13.8V (500mA Max)

<SHD> Denotes shielded cable

**Figure 7- Rear Auxiliary Harness Connector and Pinout**

### ***Digital Pulsed Input ( DPI )***

Digital Pulsed Inputs are capable of accepting pulsed input information such as for a road speed sensor. These inputs measure the time periods between the pulses and can process this information to provide quantities such as road speed.

One additional input can be connected using the Optional Rear Auxiliary Harness ( HT040003 )

### ***Digital Pulsed Outputs ( DPO )***

Digital Pulsed Outputs are capable of producing pulsed waveforms with varying duty and frequency. DPO's can be used to control various devices such as thermo-fans, shift lights, bypass air control valves, boost control solenoids etc.

When a Digital Pulsed output is activated by the ECU the output will switch to ground. Solenoid valves and shift lights etc can be run directly from the output, however high current devices such as thermo-fans and additional fuel pumps must be activated through a relay. This way the DPO is only switching a relay and not a high current draw device.

Two additional outputs can be connected using the Optional Rear Auxiliary Harness ( HT040003 )

**Digital Pulsed Outputs are limited to 800mA Max current draw.**

### ***Digital Switched Outputs ( DSO )***

Digital Switched Outputs are capable of switching to ground

DSO's can be used to control relays in an on / off state only.

Two additional outputs can be connected using the Optional Rear Auxiliary Harness ( HT040003 )

**Digital Switched Outputs are limited to 800mA Max current draw.**

### ***Analogue Voltage Inputs ( AVI )***

Analogue Voltage Inputs accept variable voltage inputs from 0V to 5V. These inputs can also accept switch inputs that change between two different voltage levels.

The On Voltage and Off Voltage define what the thresholds are between the On and Off states. The Voltage can be viewed as a channel in the software to determine the thresholds for a switched input.

Two additional sensors or switched inputs can be connected using the Optional Rear Auxiliary Harness ( HT040003 )

### ***Wire connections***

When using crimp connectors ensure that the correct crimping tool is used – if in doubt do a pull test on a crimp connector, the wire should break before the wire pulls out of the crimp. Terminal soldering can weaken a connection and should only be used as a last resort. If solder joints are used, ensure joints are well isolated from movement as solder joints are prone to fracture.

When splicing 2 wires it is preferable to use a crimp splice – again if using a solder joint, ensure joint is limited in its range of possible movement as solder joints are prone to fracture. Always use heat-shrink sleeving to insulate wires.

## The Haltech CAN Network

The Haltech CAN network allows for simple and effective expansion in ECU capability and functionality without having to go to the trouble of wiring in a whole new computer.

Expansion is made possible by the addition of multiple expansion devices that communicate to the main ECU via a Control Area Network (CAN).

Installation time and costs are kept to a minimum as all expansion devices are powered up from the main ECU via the pre-terminated connection cable that comes with each expansion device.

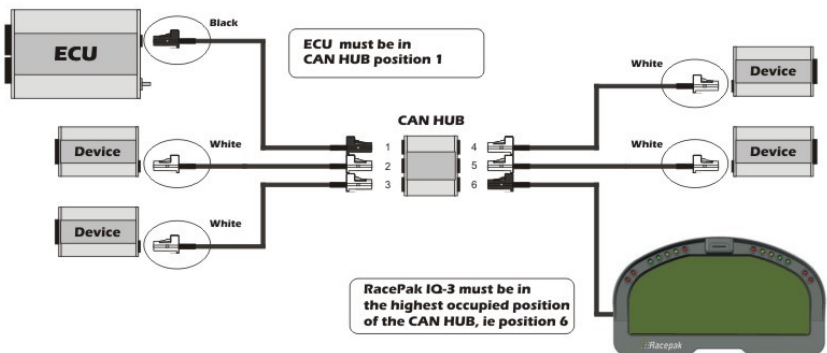
Simply connect the device directly to the 8 pin CAN connector on the rear of the ECU or connect using an optional Haltech CAN Hub (order as part # HT059990) if multiple expansion devices are required).

Each expansion device is pre-programmed with a unique ID code which allows it to be recognised on the network and work correctly first time every time.

For current available expansion devices please go to our website at [www.haltech.com](http://www.haltech.com)

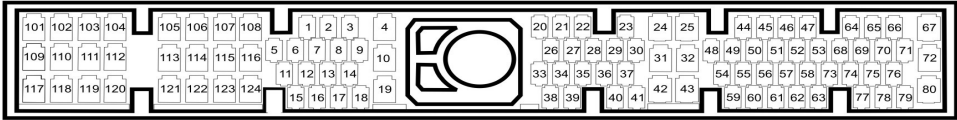


**Figure 8 – Haltech ECU connected to a Racepak Dash**



**Figure 9 – Haltech ECU connected to 5 Auxiliary CAN based devices**

## ECU Pinout



### Looking into ECU

Pin #	Function Description
1	IGN #1 (No. 1 Ignition Signal)
2	IGN #5 (No. 5 Ignition Signal)
3	IGN #3 (No. 3 Ignition Signal)
4	ECM Relay control
5	Tachometer
6	-
7	IGN #6 (No. 6 Ignition Signal)
8	IGN #2 (No. 2 Ignition Signal)
9	IGN #4 (No. 4 Ignition Signal)
10	-
11	AAC Valve Control Signal
12	-
13	Fuel Pump Relay
14	Air Conditioner Control signal
15	-
16	-
17	Check Engine Light
18	-
19	-
20	Ignition Switch Start Signal
21	Air Conditioner Switch Signal
22	-
23	Throttle Position Sensor Signal
24	Ignition Switch Signal
25	Ground
26	* Power Steering Oil Pressure Switch
27	-
28	-
29	Vehicle Speed Sensor
30	* Headlamp Switch Signal
31	Ignition Power Supply
32	Ground
33	* Idle Position Switch Signal
34	-
35	-
36	-
37	Throttle Opening Signal
38	-
39	* Neutral Signal
40	-
41	* Full Switch Signal
42	-
43	Sensor Ground
44	Crank Angle Sensor (120deg Sensor)
45	Crank Angle Sensor (120deg Sensor)
46	Crank Angle Sensor (1deg Sensor)
47	* Turbo Pressure Sensor Signal
48	Sensor Power Supply
49	* Rear Defogger Signal
50	Heated Oxygen Sensor Signal
51	* Throttle Motor Sensor Signal
52	-
53	* Motor Throttle Switch
54	Mass Airflow Sensor Signal
55	Mass Airflow Sensor ground
56	Engine Coolant Temperature Sensor Signal
57	* Refrigerant Pressure Sensor Signal
58	* Output Shaft Rotation Sensor Signal
59	-
60	-
61	-
62	Knock Sensor Signal 1
63	Knock Sensor Signal 2

Pin #	Function Description
64	-
65	-
66	-
67	Control Unit Power Supply
68	-
69	-
70	-
71	* Stop Lamp Switch
72	Control Unit Power Supply
73	-
74	-
75	-
76	-
77	-
78	Aux Fan Relay Control
79	* ECM/TCM/TCS/ABS Integrated Control Signal
80	Battery Power Supply

101	Injector #1
102	-
103	Injector #3
104	Boost Control Solenoid (RB25DET)
105	Injector #2
106	-
107	* Air Jet Swirl Control Solenoid Valve Control Signal
108	Canister Purge Signal
109	Control Unit Power Supply Feedback
110	Injector #5
111	Fuel Pump Terminal Voltage Control Output Signal
112	Injector #6
113	-
114	Injector #4
115	-
116	Injector Ground
117	Variable Timing Control Signal
118	Heated Oxygen Sensor Heater Control Signal
119	-
120	-
121	-
122	-
123	-
124	Injector Ground

\* Denotes Function Not Available

Figure 10 – Platinum Pro Plug-in Nissan Skyline R34 GT-t ECU Pinout



# ***Haltech***™

ENGINE MANAGEMENT SYSTEMS



**HALTECH HEAD OFFICE:**      PH:      +612 9729 0999  
FAX:      +612 9729 0900  
EMAIL:      [sales@haltech.com](mailto:sales@haltech.com)

**HALTECH US OFFICE:**      PH:      760 598 1941  
FAX:      760 598 1987  
EMAIL:      [usa@haltech.com](mailto:usa@haltech.com)

See the Haltech Website for your local authorized dealer.

[www.haltech.com](http://www.haltech.com)

**Version 1**