



PLATINUM
PRO PLUG-IN
Nissan Skyline
R32 / R33
(HT-055101)
QUICK START GUIDE



LIMITED WARRANTY

Lockin Pty Ltd trading as Haltech warrants the Haltech™ Programmable Fuel Injection System to be free from defects in material or workmanship for a period of **12 months** from the date of purchase.

Proof of purchase, in the form of a bill of sale or receipted invoice, which indicates that the product is within the warranty period, must be presented to obtain warranty service. Lockin Pty Ltd trading as Haltech suggests that the purchaser retain the dealer's dated bill of sale as evidence of the date of retail purchase.

If the Haltech™ Programmable Fuel Injection System is found to be defective as mentioned above, it will be replaced or repaired if returned prepaid along with proof of purchase. This shall constitute the sole liability of Lockin Pty Ltd trading as Haltech.

To the extent permitted by law, the foregoing is exclusive and in lieu of all other warranties or representations, either expressed or implied, including any implied warranty of merchantability or fitness. In no event shall Lockin Pty Ltd trading as Haltech, be liable for special or consequential damages.

DISCLAIMER

Haltech will not be held responsible for any damage caused by the incorrect installation or tuning of this product. It is the installers responsibility to ensure the wiring connections and pinouts match that of the vehicle the unit is being installed into.

Haltech has taken all care to make sure the connections match the specified vehicles listed, but variations in wiring and connections on vehicles can occur and therefore this should be checked BEFORE the unit is installed.

Haltech highly recommends installation and tuning of this product is to be carried out by a professional, with an understanding on installing and tuning engine management systems.

Misuse of this product can destroy your engine.

WARNING

This ECU is designed and sold for Racing use only. Using this product for street / road use may be prohibited by law. Please check with your local vehicle authority before using this product.

GENERAL INSTALLATION WARNING

Avoid open sparks, flames or operation of electrical devices near flammable substances. Always disconnect the battery cables when doing electrical work on your vehicle.

Do not charge the battery with a 24 Volt truck charger or reverse the polarity of the battery or any charging unit. Do not charge the battery with the engine running as this could expose the ECU to an unregulated power supply that could destroy the ECU and other electrical equipment.

All fuel system components and wiring should be mounted away from heat sources, shielded if necessary and well ventilated. Disconnect the Haltech ECU from the electrical system whenever doing any arc welding on the vehicle by unplugging the wiring harness connector from the ECU.

After completing the installation, make sure that there are no fuel leaks, and no wiring left un-insulated in case a spark or short-circuit occurs and causes a fire. Also make sure that you follow all proper workshop safety procedures. If you're working underneath a jacked-up car, always use safety stands!

PLATINUM Pro Plug-in Nissan Skyline R32/R33 **Quick Start Guide**

Congratulations on purchasing a Haltech Engine Management System. This *fully programmable Plug and Play* product opens the door to virtually limitless performance modification and tuning of your vehicle. Programmable systems allow you to extract all the performance from your engine by delivering precisely the required amount of fuel and ignition timing that your engine requires for maximum output under all operating conditions.

This quick start guide will walk you through installation of the Platinum Pro ECU into a vehicle. This guide is accompanied by the full service manual located on the software CD provided with the ECU that you or your tuner will need to refer to before completing your installation and configuration. The Manual is included in the software which can be downloaded from the Haltech website www.haltech.com

Supported Vehicles

The Platinum Pro Plug-in Nissan Skyline R32 / R33 ECU supports the following:

- Nissan Skyline R32 GT-R
- Nissan Skyline R32 GTS-t *
- Nissan Skyline R33 GT-R
- Nissan Skyline R33 GTS-t *

*** WARNING!**

Please note if RB20DET or RB25DE Engine configuration is to be supported you must swap pins 112 (Inj 6) and 114 (Inj 4) on your harness. Potential damage will occur to your engine if this is not done. Please see Appendix A.

Platinum Pro Plugin Skyline R32 / R33 Kit Includes

- Haltech Platinum Pro Plug-in ECU
- USB Cable
- Software CD
- Quick Start Guide
- Haltech Sticker

Loaded Basemap

Your Platinum Pro Plug-in has been programmed with a basemap to suit a Nissan R32 / R33 running a RB26DETT engine using standard MAF sensors. Alternatively, a basemap using the Haltech ECU Internal MAP Sensor as a load reference is available in the `C:\Users\XXXX\Documents\Haltech\ECUMaps\Nissan\R32R33` folder for you to upload into your ECU.

Please make sure you connect the Haltech ECU Internal MAP sensor to the intake manifold prior to starting the vehicle.

Please ensure you load, modify and check the corresponding basemap for your application before attempting to start the vehicle.

ECU Installation

To install your new Platinum Pro Plug-in to your R32 / R33 Nissan Skyline, please follow the procedures below.

* Please Note the following Installation photos based on a Nissan Skyline R32 GT-R

You will require the following tools

- Screwdrivers Phillips No 1 & No 2 , Small Flat
- Socket set with 10mm socket
- Cable Ties / 3M Velcro tape or similar

1. Locate your factory ECU. This will be located on the left hand side A pillar, behind the kick panel. Remove the kick panel to access the ECU.

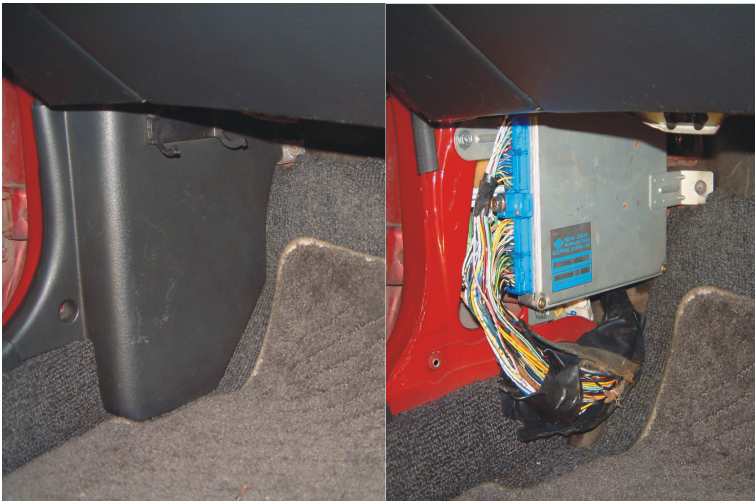

Figure 1 – Left hand side kick panel showing ECU Location

2. With the ignition turned off remove the ECU connector from the ECU by unscrewing the bolt in the centre of the connector using a 10mm socket and gently easing the connector out. Be sure to pull the connector out squarely so not to cause any damage to the pins or wires. With the connector removed proceed with un-mounting the Factory ECU from the A pillar by removing the 2 bolts securing it.



Figure 2 – Factory ECU disconnected and removed

3. Connect the Platinum Pro Plug-in ECU to the factory harness. Once again be careful that the connector enters squarely so as not to damage any pins, tighten the header bolt while pressing the sides of the connector into the ECU. At this time you can connect the optional auxiliary harness if you want to install optional sensors / relays / or solenoids. Refer to the rear auxiliary harness section for more information.



Figure 3 – Platinum Pro Plug-in ECU Connected, with optional auxiliary harness attached

- With the ECU installed do not attempt to start the vehicle. You will need to configure the ECU. The ECU is Pre Configured for use with a RB26 standard engine using the standard MAF sensors. If this is your setup then you will not have to load a basemap. However, it is still strongly recommended that you check your settings before starting your engine.

If another engine or sensor combination is to be used please go online with the ECU using the supplied ECU Manager software and load the basemap which is specific to your model (ie GT-R / GTS-t). If your selected setup requires a MAP sensor, then connect and configure the internal or external MAP sensor.

With the corresponding basemap loaded into the ECU, a standard engine should be able to be started at this point, but it is recommended that you check all the settings in the basemap before attempting to start the engine. If your engine is not standard please adjust any configuration settings affected according to your setup.

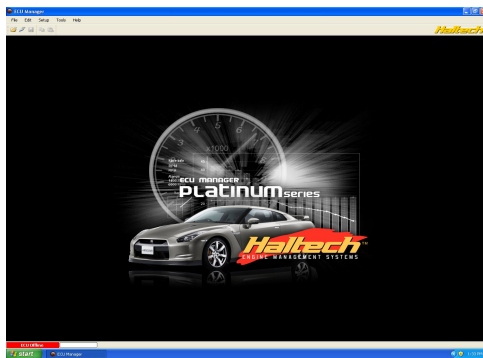

Figure 4 – Haltech ECU Manager Software

- With the engine started and running its time to tune. This is best achieved by your nearest engine tuner. See the listing of Haltech dealers on our website to find the one closest to you. Once the unit has been tuned, proceed to mount the unit in the factory location.

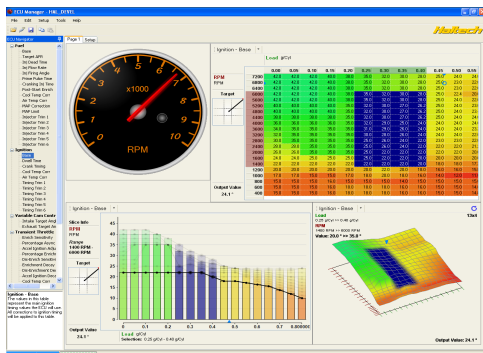

Figure 5 – Haltech ECU Manager Software tuning page

6. Mount the unit using cable ties and 3M Velcro tape or similar.



Figure 6 – Platinum Pro Plugin Mounted in a R32 GTR.

7. Once the unit is securely mounted on the A pillar you can now proceed to re-install the kick panel.



Figure 7 – Kick panel Re-installed

ECU Manager Software

ECU Manager software is used for setup, calibration and diagnostics and can be found on the CD supplied with this unit or downloaded from the Haltech website www.haltech.com

Minimum System Requirements

Operating System:	Windows 2000 SP4 / XP / Vista / Windows 7
Processor Speed:	1GHz
RAM:	256 Mb
Video Card:	128MB graphics card with 3D acceleration
USB:	1.1
Hard Drive Space:	250Mb
Minimum Screen Resolution:	1024 x 768 pixels

Installing ECU Manager

Installing ECU Manager onto your PC is performed similar to any other Windows software package. Installation is outlined below to ensure correct installation:

- 1.** Insert the CD-ROM into your PC's CD-ROM drive. The CD should automatically launch into the Haltech Browser. If the CD does not run automatically double click on the "My Computer" icon on the desktop, double click on the Haltech icon (CD- ROM drive) to start the browser software.
- 2.** The Browser will display the disclaimer and you will need to agree to the terms stated before allowing to progress. Read the Disclaimer and click on AGREE if you agree.
- 3.** Now you will be able to access all the information contained on the CD
- 4.** To download the Platinum Software, click on the Platinum Series ECU Manager Link. You will be prompted to install the software. Click "Install" to install ECU Manager and the Data Log viewer.
- 5.** Follow the software prompts and install the software.

With your programming cable (USB) attached to your ECU and the other end connected to your laptop, power up the ECU by turning your key to IGN. Start the programming software on your PC and go online with the ECU.

ECU Manager / ECU Manuals

Detailed manuals can be found in the software by pressing your F1 key or by selecting the Help tab located at the top left of the screen

ECU Manager File Extensions

When ECU manager saves the map from the Haltech ECU, it saves the map with a Haltech specific file extension.

The File extension can be broken down as follows:

Example File : xxxx.hr32r33-104

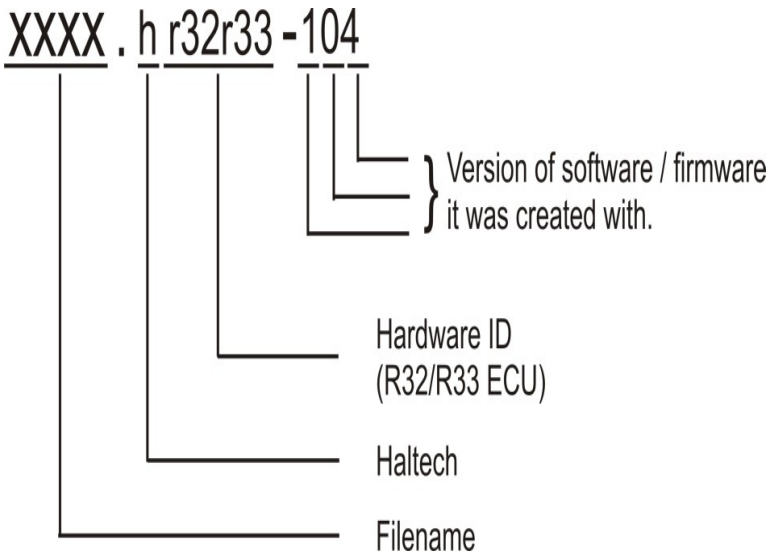

Later map versions cannot be loaded into ECU's with earlier firmware versions.

ECU Manager will upgrade earlier map versions when loading into ECU's with later firmware versions.

ECU Manager upgrades maps between versions where equivalent settings are available. However, new settings not in the original map, will be substituted with values from the new version's default map.

WHENEVER ECU MANAGER CONVERTS YOUR ECU MAP, YOU SHOULD ALWAYS CHECK YOUR MAP SETTINGS TO ENSURE THAT ALL THE APPROPRIATE SETTINGS HAVE BEEN CONVERTED CORRECTLY.

Rear Auxiliary Connector

The Platinum Pro Plugin Series allows further expansion of your ECU by the Rear Auxiliary Connector.

The Rear Auxiliary connector allows you access to:

- 1 Additional Digital Pulsed Input (DPI)
- 2 Additional Digital Pulsed Outputs (DPO)
- 2 Additional Digital Switched Outputs (DSO)
- 4 Additional Analogue Voltage Inputs (AVI)
- 2 Additional +13.8V Sensor Power Outputs (**Limited to 500mA Per output pin**)
- 2 Additional +5V Sensor Power Output (**Limited to 50mA Per output pin**)
- Additional Sensor Power and Signal Grounds

These extra Inputs / Outputs can be used to:

- Fit additional sensors. (eg MAP, Temperature and Flex Fuel)
- Control additional devices via relays
- Control additional solenoids directly (eg Aftermarket Boost Control solenoid)

The Rear Auxiliary harness is available as an optional extra. (HT-040003)



Pin #	Wire Colour	Connection
1	O	+5V (50mA Max)
2	Y	AVI1 (MAP)
3	O/B	AVI2
4	B/W	SIGNAL GROUND
5	V/B	DPO1
6	V/BR	DPO2
7	GY<SHD>	DPI1
8	R	+13.8V (500mA Max)
9	O	+5V (50mA Max)
10	GY	AVI 3
11	GY/B	AVI 4
12	B/W	SIGNAL GROUND
13	V/R	DSO1
14	V/O	DSO2
15	-	-
16	R	+13.8V (500mA Max)

<SHD> Denotes shielded cable

Figure 8 - Rear Auxiliary Harness Connector and Pinout

Digital Pulsed Outputs (DPO)

Digital Pulsed Outputs are capable of producing pulsed waveforms with varying duty and frequency. DPO's can be used to control various devices such as thermo-fans, shift lights, bypass air control valves, boost control solenoids etc.

When a Digital Pulsed output is activated by the ECU the output will switch to ground. Solenoid valves and shift lights etc can be run directly from the output, however high current devices such as thermo-fans and additional fuel pumps must be activated through a relay. This way the DPO is only switching a relay and not a high current draw device.

Two additional outputs can be connected using the Optional Rear Auxiliary Harness (HT-040003)

Digital Pulsed Outputs are limited to 800mA Max current draw.

Digital Switched Outputs (DSO)

Digital Switched Outputs are capable of switching to ground
DSO's can be used to control relays in an on / off state only.

Two additional outputs can be connected using the Optional Rear Auxiliary Harness (HT-040003)

Digital Switched Outputs are limited to 800mA Max current draw.

Analogue Voltage Inputs (AVI)

Analogue Voltage Inputs accept variable voltage inputs from 0V to 5V. These inputs can also accept switch inputs that change between two different voltage levels. The On Voltage and Off Voltage define what the thresholds are between the On and Off states. The Voltage can be viewed as a channel in the software to determine the thresholds for a switched input.

Two additional sensors or switched inputs can be connected using the Optional Rear Auxiliary Harness (HT-040003)

Analogue Temperature Inputs (ATI)

Analogue Temperature Inputs accept variable resistance sensors.

These inputs have a pull – up resistor connected to them to allow them to be used with most automotive temperature senders (Variable resistance thermistor types).

Two additional sensors can be connected using the Optional Rear Auxiliary Harness (HT-040003)

Wire connections

When using crimp connectors ensure that the correct crimping tool is used – if in doubt do a pull test on a crimp connector, the wire should break before the wire pulls out of the crimp. Terminal soldering can weaken a connection and should only be used as a last resort. If solder joints are used, ensure joints are well isolated from movement as solder joints are prone to fracture.

When splicing 2 wires it is preferable to use a crimp splice – again if using a solder joint, ensure joint is limited in its range of possible movement as solder joints are prone to fracture. Always use heat-shrink sleeving to insulate wires.

The Haltech CAN Network

The Haltech CAN network allows for simple and effective expansion in ECU capability and functionality without having to go to the trouble of wiring in a whole new computer.

Expansion is made possible by the addition of multiple expansion devices that communicate to the main ECU via a Control Area Network (CAN).

Installation time and costs are kept to a minimum as all expansion devices are powered up from the main ECU via the pre-terminated connection cable that comes with each expansion device.

Simply connect the device directly to the 8 pin CAN connector on the rear of the ECU or connect using an optional Haltech CAN Hub (order as part # HT-059990) if multiple expansion devices are required).

Each expansion device is pre-programmed with a unique ID code which allows it to be recognised on the network and work correctly first time every time.

For current available expansion devices please go to our website at www.haltech.com



Figure 9 – Haltech ECU connected to a Racepak Dash

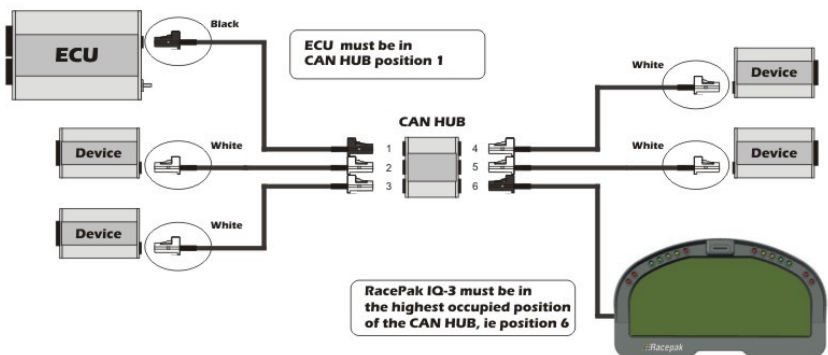
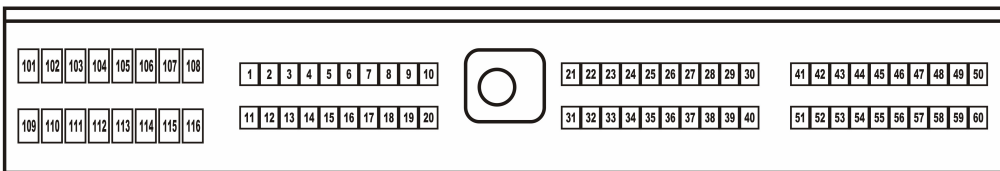

Figure 10 – Haltech ECU connected to 5 Auxiliary CAN based devices

ECU Pinout



101	INJ1 (No.1 Injector)
102	Fuel Pump High Speed (R33 GT-R Only)
103	INJ3 (No.3 Injector)
104	Fuel Pump Terminal Volt Control Output 1
105	INJ2 (No.2 Injector)
106	Fuel Pump Terminal Volt Control Output 2
107	Ground (Injector)
108	Ground (Injector)
109	Injector Power Supply
110	INJ5 (No.5 Injector)
111	-
112	INJ6 (No.6 Injector)
113	Variable Cam Timing Solenoid (RB25 Only)
114	INJ4 (No.4 Injector)
115	-
116	Ground (Injector)

21	RX - Receive (Control unit data)
22	TX - Transmit (Control unit data)
23	Knock Sensor 1 (cyl 1-3)
24	Knock Sensor 2 (cyl 4-6)
25	Wastegate Control Solenoid Valve
26	Ground (Air Flow Meter)
27	Air Flow Meter Signal (Rear)
28	Engine Temperature sensor
29	Exhaust Gas Sensor (Front)
30	Ground (TPS, Coolant)
31	Clock (Synchronization Signal)
32	Monitor and Check Lamp
33	-
34	Ground (Air Flow Meter)
35	Air Flow Meter Signal (Front)
36	Intake Air Temperature Sensor
37	-
38	Throttle Opening Output
39	-
40	-

1	IGN #1 (No. 1 Ignition Pulse)
2	IGN #5 (No. 5 Ignition Pulse)
3	IGN #3 (No. 3 Ignition Pulse)
4	AAC (Auxillary Air Control Valve)
5	-
6	Sub Electrical Fan Relay (Engine Temp Switch)
7	Tachometer Speed Signal
8	-
9	Air Conditioner Relay
10	Ground (Ignition Signal System)
11	IGN #6 (No. 6 Ignition Pulse)
12	IGN #2 (No. 2 Ignition Pulse)
13	IGN #4 (No. 4 Ignition Pulse)
14	-
15	-
16	ECCS Relay
17	-
18	Fuel Pump Relay
19	Power Steering Switch (Thermo Fan R33 GT-R)
20	Ground (Ignition Signal System)

41	Crank Angle Sensor (120deg Sensor)
42	Crank Angle Sensor (1deg Sensor)
43	Ignition Switch Start Signal
44	Neutral Switch
45	Ignition Switch (IGN)
46	Air Conditioner Switch
47	Check (Diagnosis activation)
48	Throttle Sensor Power Supply (5V)
49	Control Unit Power Supply (12V)
50	Ground (Control Unit)
51	Crank Angle Sensor (120deg Sensor)
52	Crank Angle Sensor (1deg Sensor)
53	Vehicle Speed Sensor
54	Throttle Valve Switch (Idle Connection)
55	Exhaust Gas Sensor (Rear)
56	Throttle Opening Output (4WD System)
57	Throttle Valve Switch Power Supply
58	Battery Power Supply
59	Control Unit Power Supply (12V)
60	Ground (Control Unit)

Figure 11 – Platinum Pro Plugin R32 / R33 ECU Pinout

Appendix A

For this ECU to work on a RB20DET or RB25DE Engine configurations the following wires must be swapped within your factory harness as the Injector outputs between the RB25DET and RB26 configurations to the RB20DET or RB25DE configurations are different.

Please move the pin 112 (Injector 6) to position 114

Please move the pin 114 (Injector 4) to position 112

Please see below

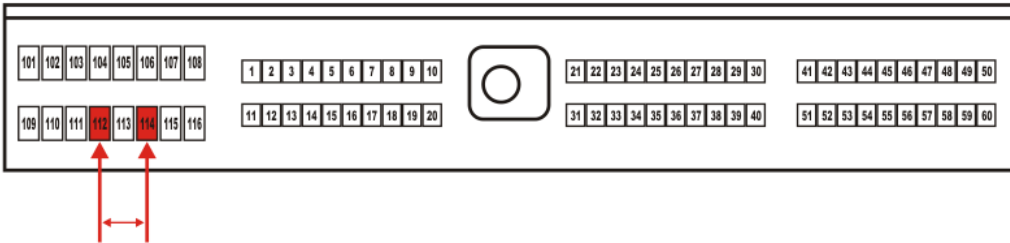

Figure 12 – Harness connector looking at wire side

