

Use a stone safe adhesive such as DAP KwikSeal Ultra along brace top, and where brass attaches to sink



C52 Milano Sink with PFS-TDWL Elemental Wall Bracket

Due to the hand-carving of each piece, small variances in shape and size are to be expected.

SIZE **A** DWG. NO. C52 w PFS-TDWL Elemental Wall Brackets REV. **A**

WEIGHT: SHEET 1 OF 1

©2019 Stone Forest, Inc.

DO NOT SCALE DRAWING

link to Youtube for brace installation video:
<https://www.youtube.com/watch?v=JeCHV377MJY&feature=youtu.be>

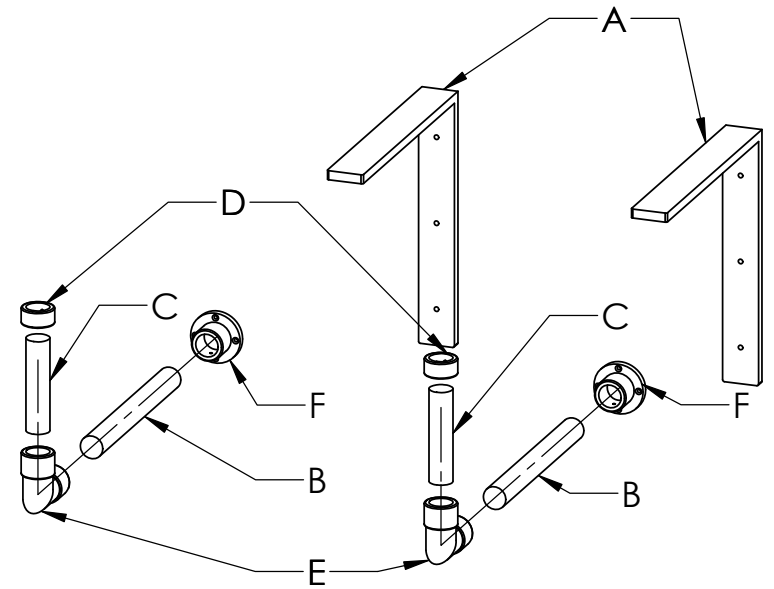
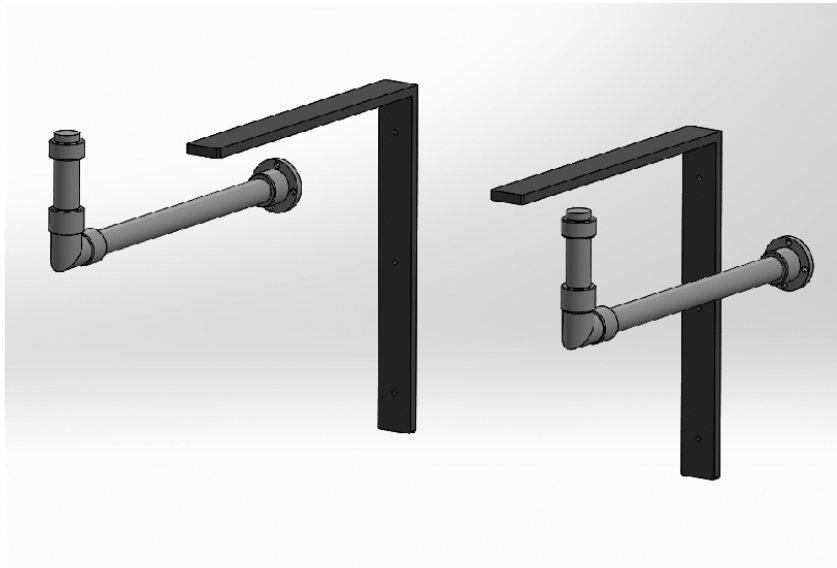

part	item code	description	qty	X
(A)	PFS-BRKT 14BL (FB #30053)	14"x14"x2" HIDDEN STEEL BRACKET	X2	
	2" #8 screws-black - to attach hidden steel brackets to blocking [for part (A) above]		X6	
(B)	PFS-TB-11	11" TUBE	X2	
(C)	PFS-TB-5	5" TUBE	X2	
(D)	PFS-CLLR	COLLAR/ SET	X1	
(E)	PFS-ELBOW	ELBOW	X2	
(F)	PFS-WALL	ESCUTCHEON	X2	
	2" #8 screws BR, MB or PN w/wall anchors [for part (F) above]		x10	
allen wrench (1), white gloves (1pr), (2), extra set screws (6)				



circle one: CLASSIC FACET
 stand finish _____

DO NOT SCALE DRAWING

©2021 Stone Forest, Inc.



PFS-TDWL-52 Elemental Wall Unit 52-26

DWG. NO. PFS-TDWL-52 - Elemental Wall Unit 52-26



SKU	SIZE	FINISH
30030	8"x8"	Steel
30031	8"x8"	Black
30062	8"x8"	White
30040	10"x10"	Steel
30041	10"x10"	Black
30063	10"x10"	White
30048	12"x12"	Steel
30049	12"x12"	Black
30064	12"x12"	White
30052	14"x14"	Steel
30053	14"x14"	Black
30065	14"x14"	White
30056	16"x16"	Steel
30057	16"x16"	Black
30066	16"x16"	White
30058	18"x18"	Steel
30059	18"x18"	Black
30067	18"x18"	White
30060	20"x20"	Steel
30061	20"x20"	Black
30068	20"x20"	White

Material Thickness:

1/4" - (8x8 - 12x12)

3/8" - (14x14 - 16x16)

1/2" - (18x18 - 20x20)

Bracket Specifications:

See length and height listed to the left

Width: 2"

Hole Specifications:

No Holes on Top Flange - Use adhesive

Size 8x8 - 14x14: (3) 1/4" diameter holes

Size 16x16 - 18x18: (4) 1/4" diameter holes

Size 20x20: (4) 1/2" diameter holes

Carry Capacity:

375 lbs each.

Recommended Installation Kit:

Standard Fastener System - SKU: 39988

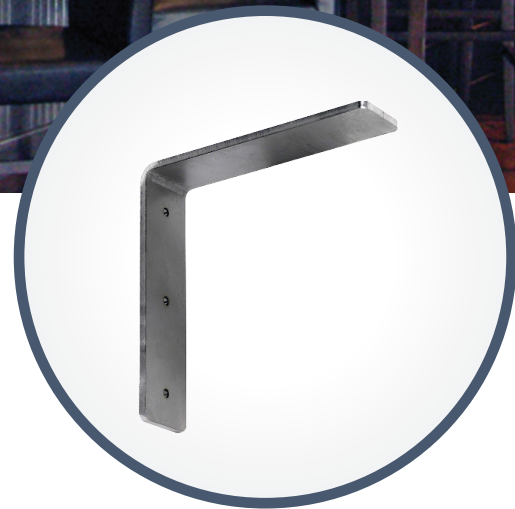

FREEDOM HIDDEN COUNTERTOP BRACKET INSTALLATION GUIDELINES

Every successful countertop installation begins with good planning and action. Do not wait until the last minute to order your countertop supports, fasteners or adhesives for installation. Make sure that all aspects of the knee wall and support substructure are considered and discussed to ensure that your countertop installation will be smooth and that your countertop support products will be sufficient.

Note that this installation document should not be considered a specific recommendation for your particular application. Federal Brace cannot provide installation guidelines to meet the particulars of every application. This document should be considered a help sheet that provides considerations about the general characteristics of a particular type of support and installation.

Characteristics of the Freedom Hidden Countertop Support Bracket

The material thickness of the Freedom Bracket is 1/4", in Sizes 8" x 8" to 14" x 14", 3/8" in sizes 14" x 14"-16' x 16", and 1/2" in sizes 18" x 18"-20" x 20". The Freedom style countertop bracket is suggested for use in island extension applications where 2/3 of counter rests on cabinet base. The Freedom is not useful in the elevated countertop applications or wall mounted countertop.

Preparations for the Freedom Bracket

The Freedom Countertop Supports come in black steel and raw steel. If you have ordered your Freedom Brackets unfinished (without paint) you will need to finish them before installation. Make sure you clean the bracket of any machine oil or rust

preventative before painting. Once clean and dry apply a metal compatible paint to the bracket completely. Let the first coat dry, then apply at least 1 more coat. Before installing the bracket, the paint should be allowed to dry completely.

Considerations when Installing Freedom Hidden Countertop Brackets

Whenever installing the Freedom Countertop Brackets make sure that you provide the thickest possible substructure (at least 1.75") on which to fasten the bracket. You will want the fasteners to have as much "biting" material as - possible. (This will provide a secure fastening of the brackets.) Also, the substructure should be tied into the floor. Remember, a weak substructure makes for a weak installation.

With the substructure in place and sturdy, measure out your bracket pattern. We suggest that you space the Freedom style bracket no greater than 18" apart on a standard application. Once you have your bracket support pattern set up you can attach your first bracket to the substructure. Make sure that when you fasten your bracket that you check for level in all directions. The bracket should be straight up and down and level vertically as well as horizontally. This will give the best possible result to

your countertop. The top of your bracket should not extend over your support substructure but should meet flush with the top. You will want to use a level to determine the positioning of the top of the bracket to the top of your substructure.

When manufacturing the Freedom Countertop Supports we attempt to hit the angle break at 90 degrees 100% of the time. However, we may be slightly off of that mark. If this is the case with your bracket, you should use shims in your installation to bring the bracket to level. Shims can be placed directly behind the down flange or you may need to slightly plane the support stud to allow for the bracket to sit flush and level. Once all the brackets are in place, you will want to wipe them down to get rid of any handprints or other debris.

Just before installation of your counter you need to apply adhesive or silicone to the top of the bracket to adhere it to the counter. Once the counter is in place, you can caulk around the edge of the brackets if you choose. This will give greater adherence to the countertop and cover any gap between the brackets and counter.

Final step is to enjoy your work and your new kitchen counter. We are happy that you chose to support your beautiful counters with Federal Brace brackets. We would be thankful if you would send us images of your new kitchen and our brackets under your counters. We enjoy seeing Federal Brace supports at work. Also, know that the highest compliment Federal Brace can be given is a reference from our customers to friends and family. If you have enjoyed your buying experience with Federal Brace please let someone know

For any questions or comments please to contact us by email at customerservice@federalbrace.com or by phone at (877) 353-8899. If you are a visual learner, check out our installation videos on our YouTube channel Don't forget to share your projects with your new Federal Brace brackets on Twitter and Instagram, just tag us @FederalBrace. Like us on Facebook, and check out our boards on Pinterest for more home improvement/decor and DIY project ideas.



PROUDLY
AMERICAN
MADE