

Onyx Plinth Fountains
Item# NF100-60 and NF100-48

shown w/ stainless steel supports Item #NPI-100 SS

SIZE DWG. NO.

A

REV.

A

WEIGHT:

SHEET 1 OF 1

©2019 Stone Forest, Inc.

Due to the hand-carving of each piece, small variances in shape and size are to be expected.

DO NOT SCALE DRAWING

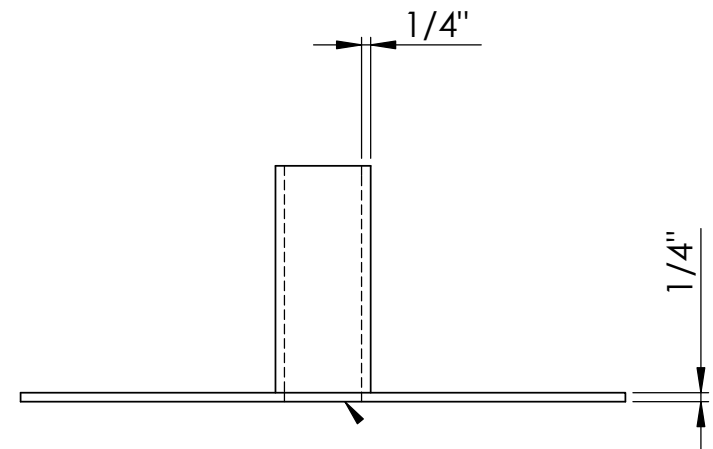
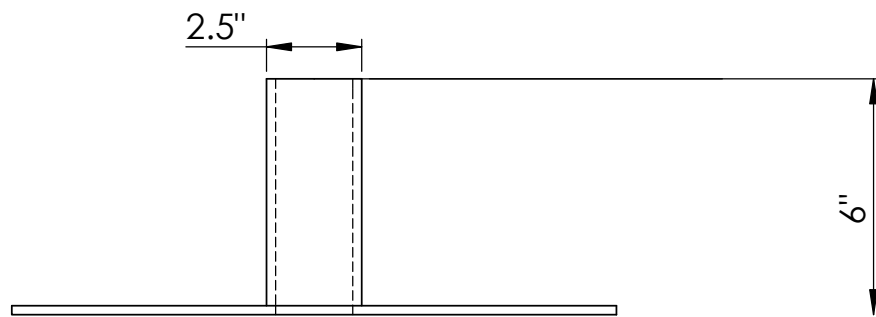
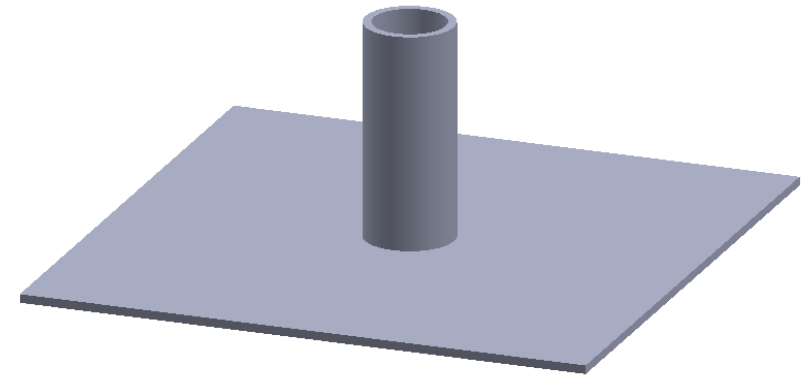
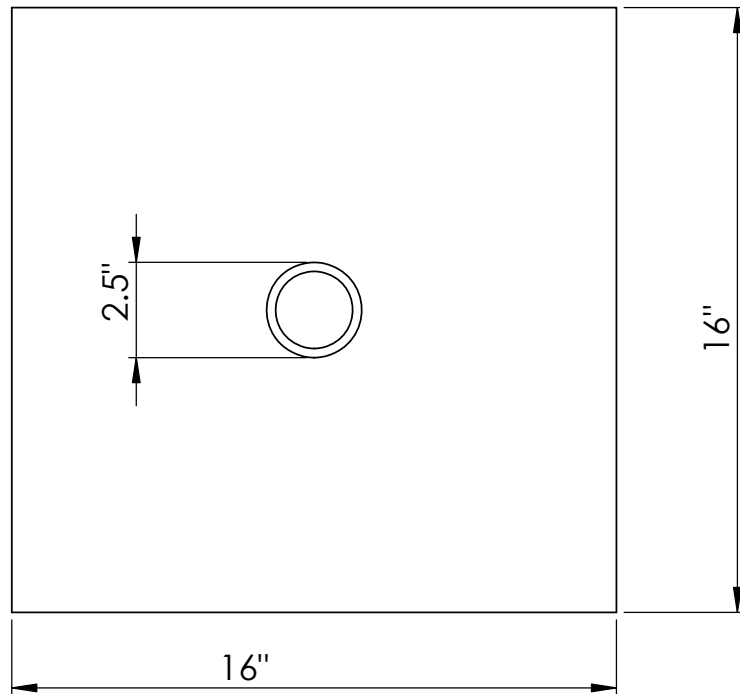

stainless support for plinths

Due to the hand-carving of each piece, small variances in shape and size are to be expected.

SIZE **A** DWG. NO. stainless support for plinth columns

REV. **A**

MATERIAL Stainless steel

WEIGHT: lbs SHEET 1 OF 1

FINISH Brushed

©2015 Stone Forest, Inc.

DO NOT SCALE DRAWING