

NOTE:

- Install according to your local building codes
- Consult concrete contractor or engineer for wall thickness and reinforcement needed for weight

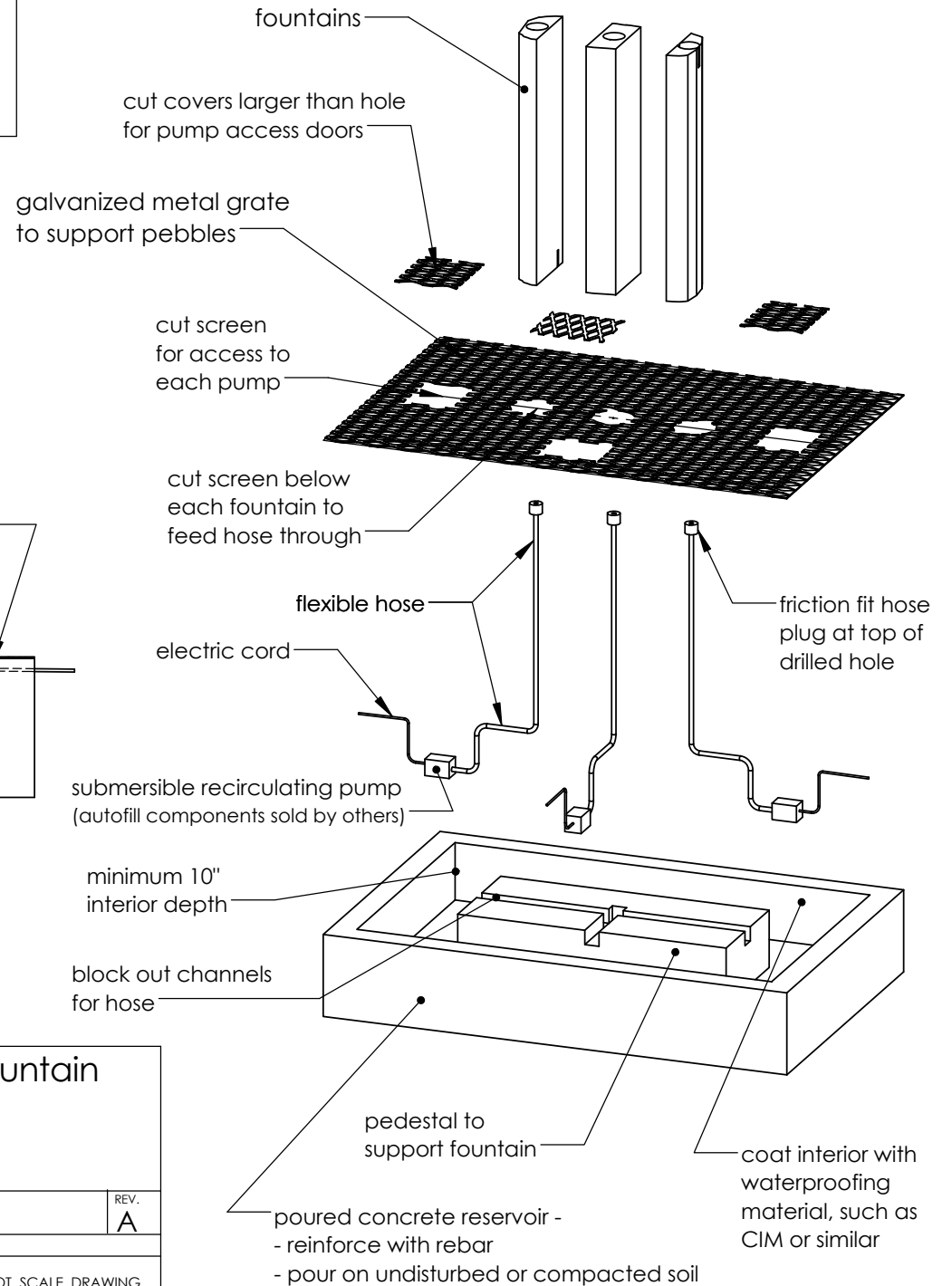
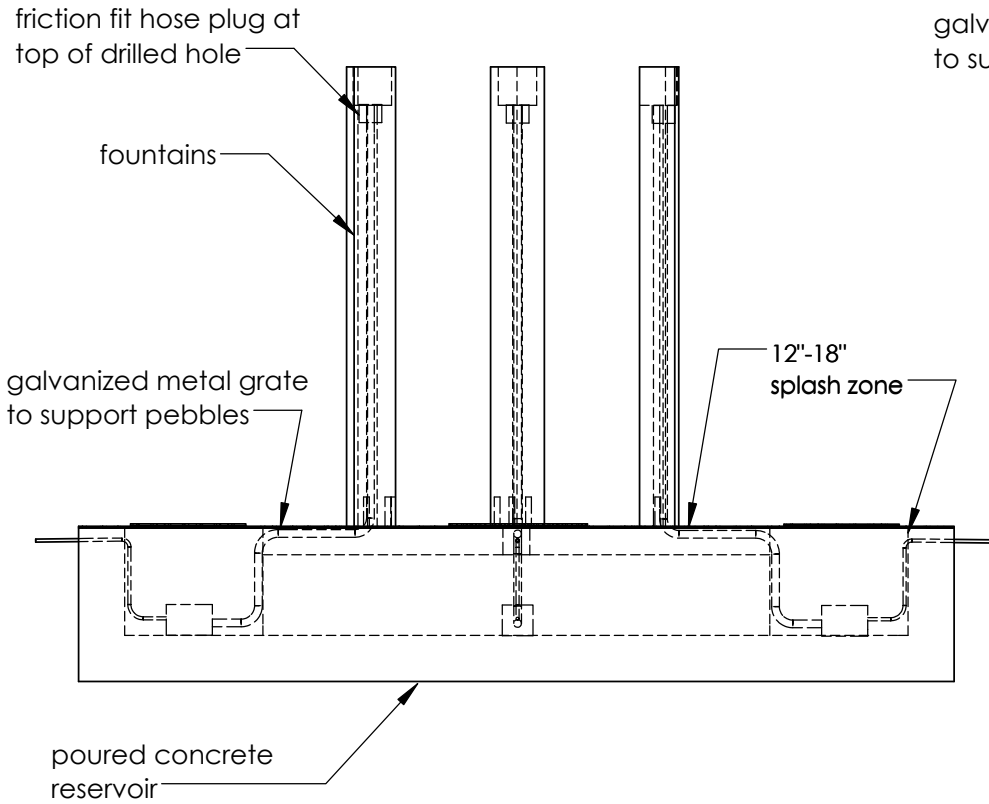

Custom reservoir for Triple Basalt Fountain

SIZE	DWG. NO.	REV.
A	Com Install Rectangle	A

WEIGHT: SHEET 1 OF 1

©2022 Stone Forest, Inc. DO NOT SCALE DRAWING