

LulzBot TAZ PRO / Workhorse ABS+ Enclosure

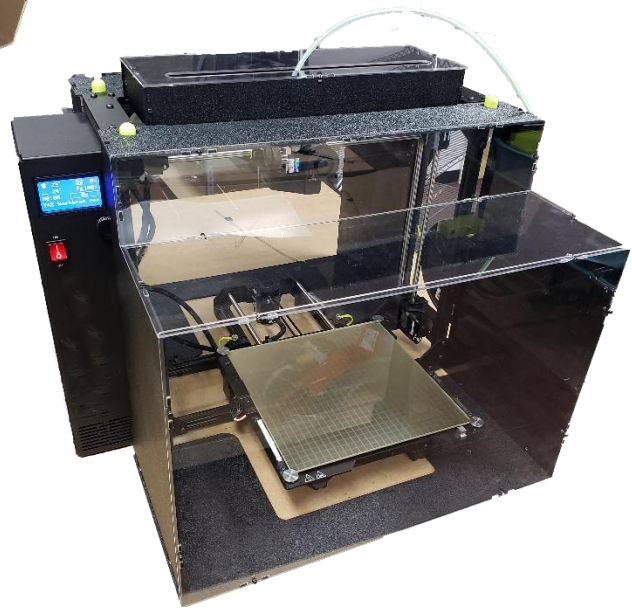

Designed and manufactured by

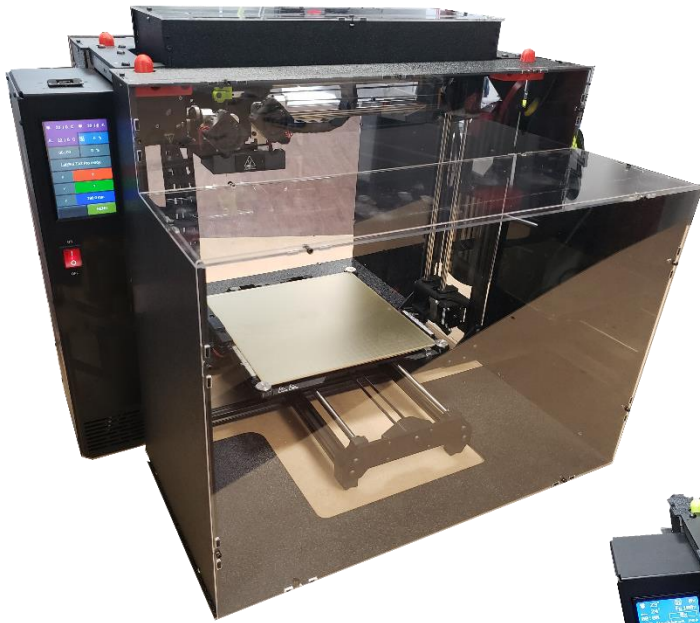

Made in Delaware, USA

This work is licensed under a Creative Commons Attribution-ShareAlike 4.0 International License. Created by David Randolph and printedsolid.com



What's Included?

2	Part A: ABS Top mount with holes	1	Part K: ABS Front Left Taz Pro
2	Part B: Shelf	1	Part WK: ABS Front Left Taz Workhorse
2	Part C: Short Panel	1	Part L: ABS Front Right
2	Part D: Main panel	1	Part M: ABS Rear Right / Pro & Workhorse
2	Part E: ABS Bottom	70	M3-10mm bolts
1	Part F: Taz Pro Machine Side	70	M3 square nuts
1	Part WF: Taz Workhorse Machine Side	4	M4-8mm bolts
1	Part G: Top Cover acrylic	4	M4 square nuts
2	Part H: ABS Top Front and Back	8	M5-20mm bolts
2	Part I: ABS Top Sides	5	Black printed brackets
1	Part J: ABS Rear Left / Pro & Workhorse		

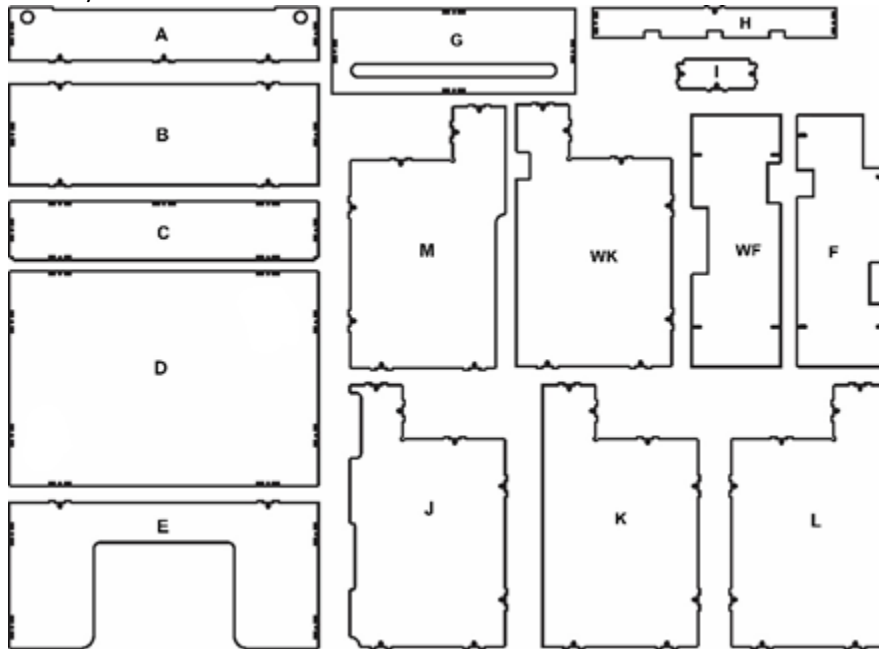

Tools Needed

3mm hex driver / 4mm hex driver Optional: Painters tape / Flat razor

Time Required

2-3 hours based on skill level

You can crack the acrylic very easily by over tightening.

Do not over tighten the screws. Tighten them just enough to hold without moving around.

If you do crack a panel please contact your reseller for assistance.

The enclosure is made from cast acrylic for optical clarity that helps reduce visual distortions. Do not use household cleaners to clean the Acrylic. Use dish soap or hand wash and do not scrub or use any abrasives.



Step 1:

Note the letters on the individual pieces and remove the protective covering from both sides of the pieces. The Black ABS pieces do not have a protective covering. There is a textured side and a smooth side to the ABS pieces. It is important that the protective covering be removed before assembly of each part since they interlock into one another preventing you from removing it later. Use either your fingernail or a flat razor to pull up on the edge of the protective covering. Take your time and pull slowly to get any additional stray pieces.

Step 2:

Install the brackets on the front and rear of the printer. Using a 3mm hex driver to remove the existing screws and install the brackets using the included M5-20mm bolts and a 4mm hex driver. While there is still support for the top of the printer with the screws removed it is recommended to do one bracket at a time. Note that the original nut in the extrusion might shift once you remove the screw. Don't worry if this happens, you will need to move the nut back into place with a small tool like a hex drive. The bracket with the cutout on the back is for the rear right corner opposite the control box on the Taz Pro to allow for room for filament sensor. The Taz Workhorse uses the remaining bracket without the cutout for the right rear corner.

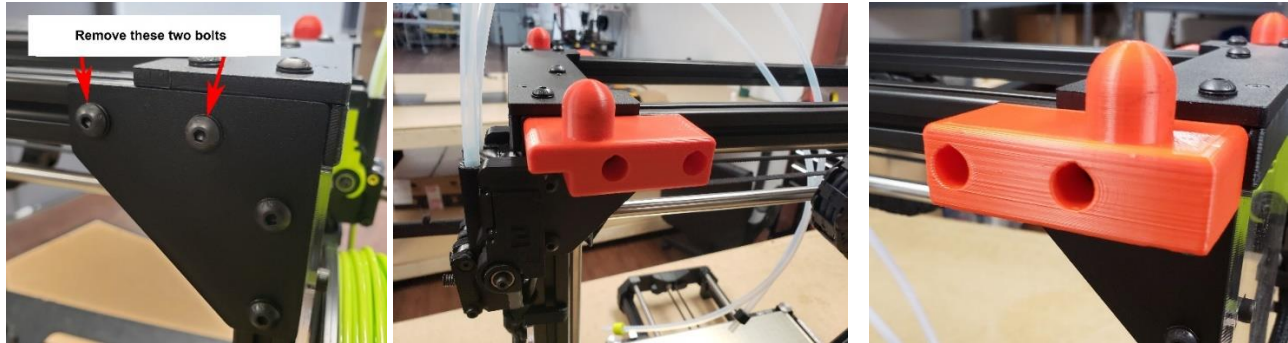

Colored brackets were used to make them more visible in these pictures, but the ones included in your kit are black.

Step 3:

Gently set the printer on its side with the control box flat on the work surface. It is a good idea to lay down a towel or something soft to prevent scratching the side of the printer. Install (Part F) for the Taz Pro and (Part WF) for the Taz workhorse on the side using the 4 M4-8mm bolts and M4 square nuts. Remove the two feet off the bottom of the printer. Slide 2 square nuts in from the bottom of the machine into the extrusion on each side. Tighten down the bolts just enough to prevent slippage. The cut outs on the sides allow for the arms and filament guide to be usable. Reinstall the two feet you removed earlier.

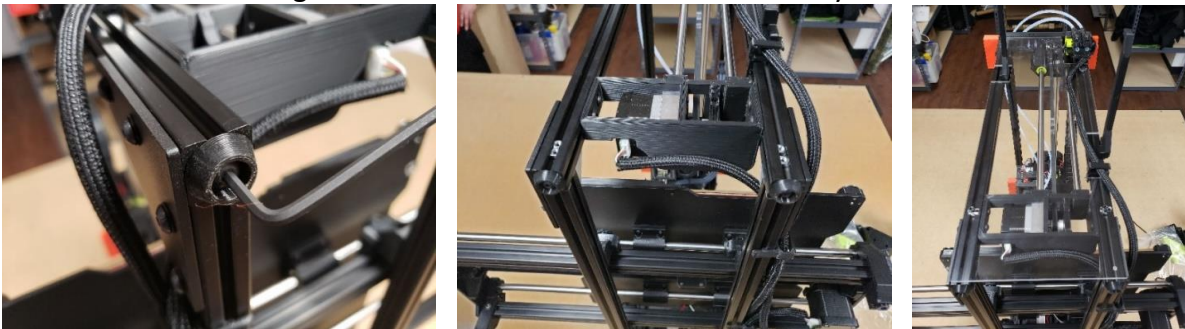

Step 4: Front Enclosure ABS pieces

Attach the black ABS Bottom (Part E) texture side toward the inside to the black ABS Front Left (Part K) for the Taz Pro and (Part WK) for the Taz workhorse texture facing out and black ABS Front Right (Part L) texture facing out. Then attach the black ABS top mount with holes (Part A) texture facing up. The square nuts sits in the slot and the M3-10mm bolts goes through the hole and into the square nut. If you find it difficult to keep the nut in place while you insert the bolt you can use some painters tape to hold the nut in place for assembly. **DO NOT OVER TIGHTEN THE BOLTS.** Tighten them by hand and slightly more than 1/8th of a turn with a hex driver is enough to hold everything together.

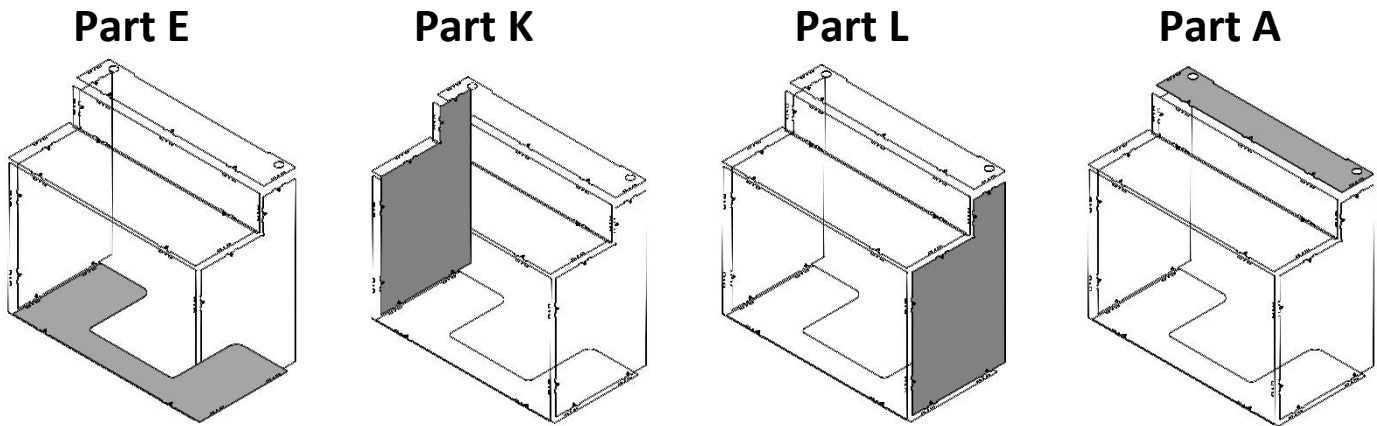

Step 5: Front Enclosure Acrylic

Attach the acrylic short panel (Part C) with the corner knockouts facing down. Then install the shelf (Part B) and finally the Main Panel (Part D). The square nuts sits in the slot and the M3-10mm bolts goes through the hole and into the square nut. If you find it difficult to keep the nut in place while you insert the bolt you can use some painters tape to hold the nut in place for assembly. **DO NOT OVER TIGHTEN THE BOLTS.** Tighten them by hand and slightly more than 1/8th of a turn with a hex driver is enough to hold everything together.

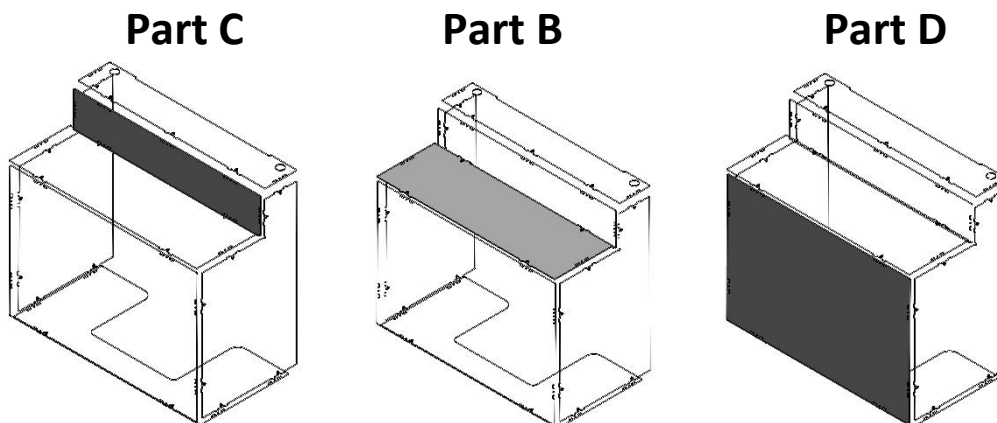

Step 6: Rear Enclosure ABS pieces

Attach the black ABS Bottom (Part E) texture side toward the inside to the black ABS Rear Left (Part J) texture facing out and black ABS Rear Right (Part M) texture facing out. Then attach the black ABS top mount with holes (Part A) texture facing up. The square nuts sits in the slot and the M3-10mm bolts goes through the hole and into the square nut. If you find it difficult to keep the nut in place while you insert the bolt you can use some painters tape to hold the nut in place for assembly. **DO NOT OVER TIGHTEN THE BOLTS.** Tighten them by hand and slightly more than $1/8^{\text{th}}$ of a turn with a hex driver is enough to hold everything together.

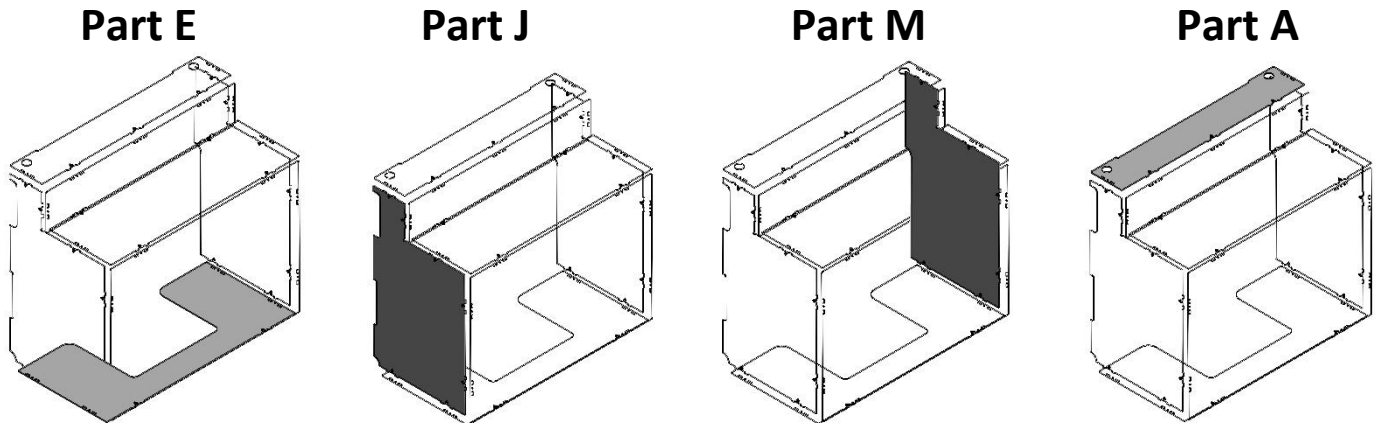

Step 7: Rear Enclosure Acrylic

Attach the acrylic short panel (Part C) with the corner knockouts facing down. Then install the shelf (Part B) and finally the Main Panel (Part D) The square nuts sits in the slot and the M3-10mm bolts goes through the hole and into the square nut. If you find it difficult to keep the nut in place while you insert the bolt you can use some painters tape to hold the nut in place for assembly. **DO NOT OVER TIGHTEN THE BOLTS.** Tighten them by hand and slightly more than $1/8^{\text{th}}$ of a turn with a hex driver is enough to hold everything together.

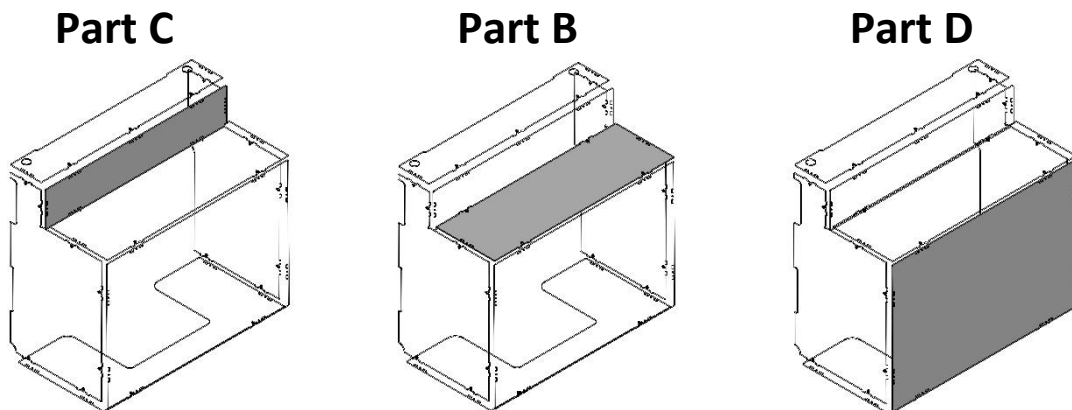

Step 8: Top Cover

Attach the acrylic Top (Part G) to the ABS Top Front and Back (Part H) with texture facing out. Then attach the ABS Top Sides (Part I) with texture facing out. The square nuts sits in the slot and the M3-10mm bolts goes through the hole and into the square nut. If you find it difficult to keep the nut in place while you insert the bolt you can use some painters tape to hold the nut in place for assembly. **DO NOT OVER TIGHTEN THE BOLTS.** Tighten them by hand and slightly more than 1/8th of a turn with a hex driver is enough to hold everything together.

Part G

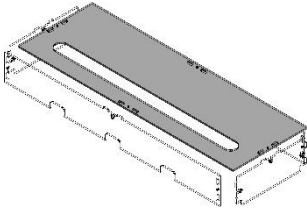

Part H x2

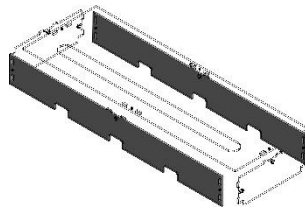

Part I x2

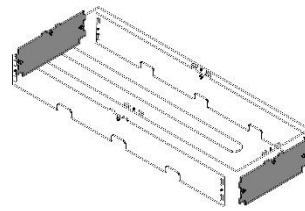

Proper Usage:

You can lift the front or back up and off the 3D printed post. The cutout on the bottom helps to clear the arms on the bed of the printer. It is normal for the cover to sit on the table and is part of the design to help reduce the risk of accidental breakage. You will also notice the post holes are slightly enlarged and the front/back covers are slightly larger than the top and side covers. This is intentional to help prevent accidental snags or breakage after repeated use.

The top cover sits on top of the printer and then you attach the Bowden tubes to the tool head. The front and back edges sit into the slots on the extrusion

Congratulations on a job well done!

All product and company names are trademarks™ or registered® trademarks of their respective holders. Use of them does not imply any affiliation with or endorsement by them.

LulzBot® is a registered trademark of Fargo Additive Manufacturing Equipment 3D

