

# LulzBot Mini and Mini2 Enclosure v2

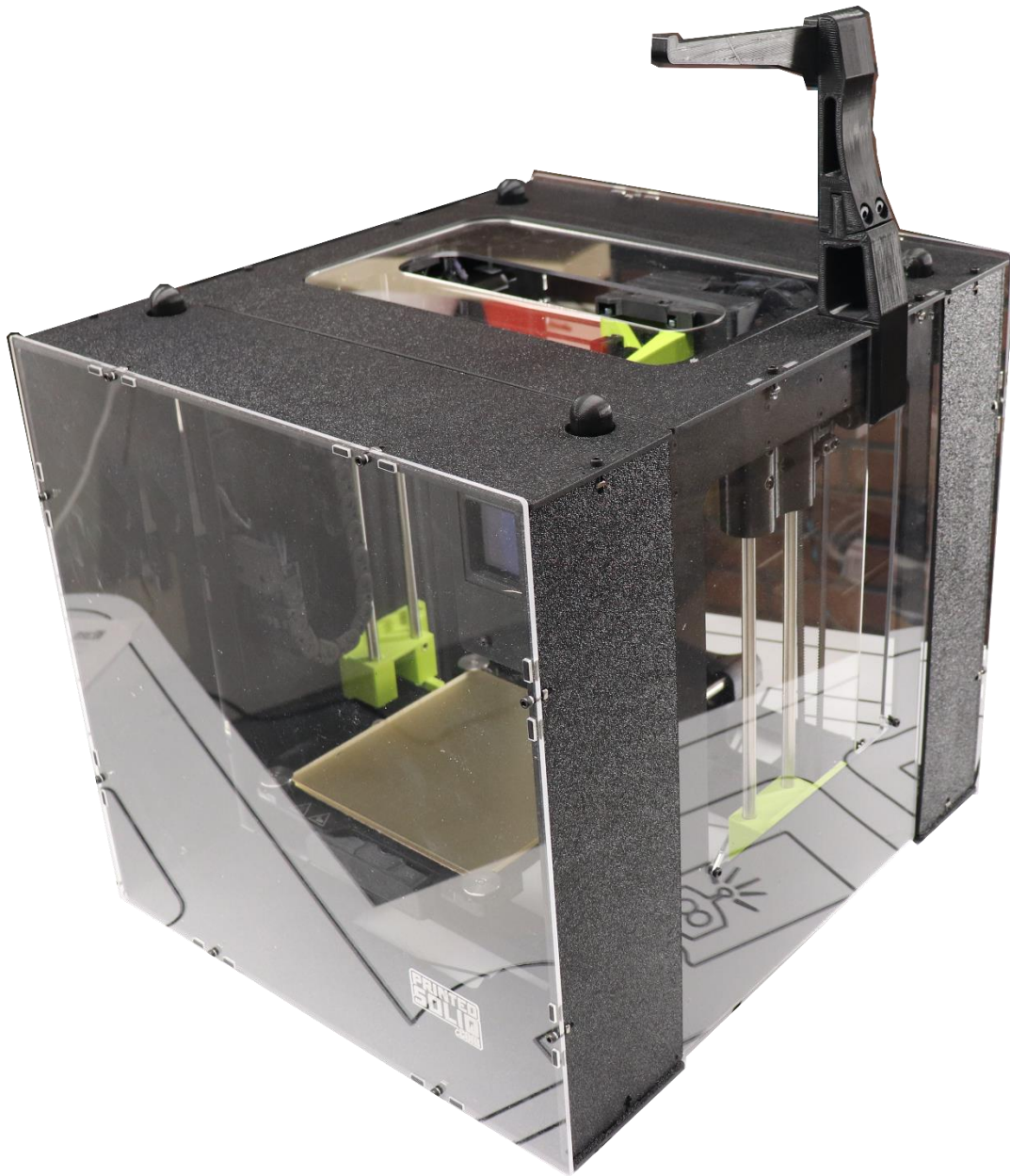

This work is licensed under a Creative Commons Attribution-ShareAlike 4.0 International License. Created by David Randolph and [printedsolid.com](http://printedsolid.com)

Designed and manufactured by



# What's Included?

2	Part A: Front and rear panel	1	Part I: ABS Short side cover
2	Part B: ABS Rear cover sides	1	Part J: Long side cover
1	Part C: ABS Rear cover top	1	Part K: ABS Top cover
1	Part D: ABS Rear cover bottom	36	M3-10mm bolts
2	Part E: ABS Front cover sides	8	M3-40mm bolts
1	Part F: ABS Front cover top	36	M3 square nuts
1	Part G: ABS Front cover bottom	2	M3 washers
1	Part H: Optional top insert	4	3D Printed brackets
		1	GLCD 3D Printed bracket

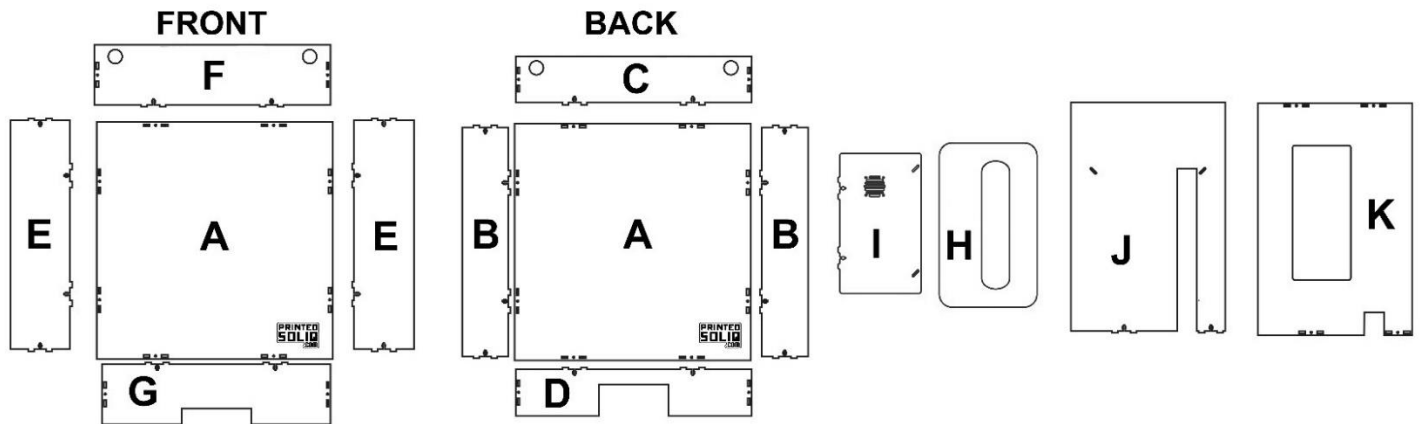

# Tools Needed

- 2mm hex driver
- 2.5mm hex driver
- Optional: Painters tape
- Optional: Flat razor

# Time Required

1-2 hours based on skill level

# You can crack the acrylic very easily by over tightening.

Do not over tighten the screws. Tighten them just enough to hold without moving around.

*If you do crack a panel please contact your reseller for assistance.*

The enclosure is made from cast acrylic for optical clarity that helps reduce visual distortions. Do not use household cleaners to clean the Acrylic. Use dish soap or hand wash and do not scrub or use any abrasives.



## Step 1:

Install the brackets on the front and rear of the printer. Using a 2mm hex driver to remove the existing screws and install the brackets using the included M3-40mm bolts and a 2.5mm hex driver. While there is still support for the top of the printer with the screws removed it is recommended to do one bracket at a time. For Printers that have a GLCD, use the thin bracket that will fit around the LCD screen. For the printers with out, use an extra corner bracket.

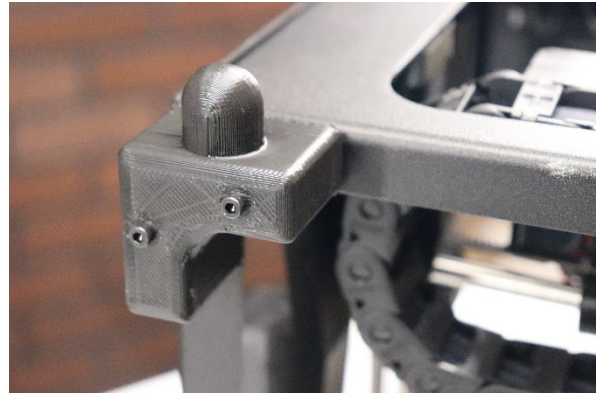

## Step 2:

Note the letters on the individual acrylic and black ABS pieces and then remove the protective covering from both sides of the acrylic pieces. While the front and back covers share similar pieces there are some differences. The sides, top and bottom are deeper for the front than for the back. This is to accommodate the build plate while keeping the enclosure total size at the tightest dimensions. It may be easier to remove the protective coverings as you do each part if you feel more comfortable working that way but it is important that the protective covering be removed before assembly of each part since they interlock into one another preventing you from removing it later. Use either your finger nail or a flat razor to pull up on the edge of the protective covering. Take your time and pull slowly to get any additional stray pieces.

## Step 3:

Set the black ABS top cover (Part K) on the top of the printer with the cutout for the spool arm aligned. It is a good idea to have the spool holder in the upright position for assembly.

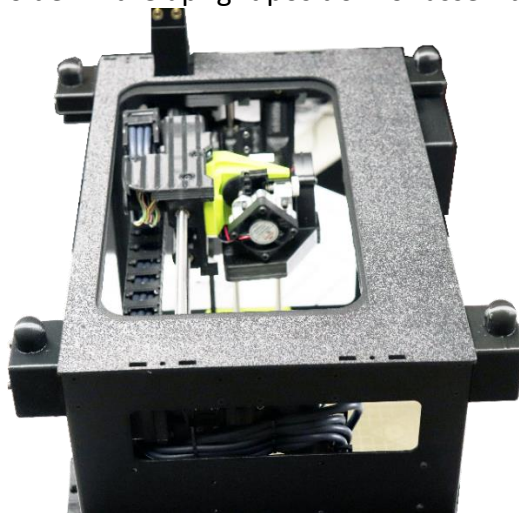

## Step 4:

If you have an LCD screen on your Mini remove the screw in the picture below then set the black ABS short side cover (Part I) on the left side of the printer by inserting the tabs into the slot on the top cover. Make sure that the vent holes are towards the front of the printer. The square nut sits in the slot and the 2 M3-10mm bolt goes through the top cover into the square nut. If you find it difficult to keep the nut in place while you insert the bolt you can use some painters tape to hold the nut in place for assembly. Then insert a M3-10mm bolt from the inside of the machine in the hole you see on the left side of the second picture below and put the M3 square nut on the outside. Finally for the slot hole on the right side of the same picture below screw in a M3-10mm bolt, no nut is required if you have an LCD screen installed.

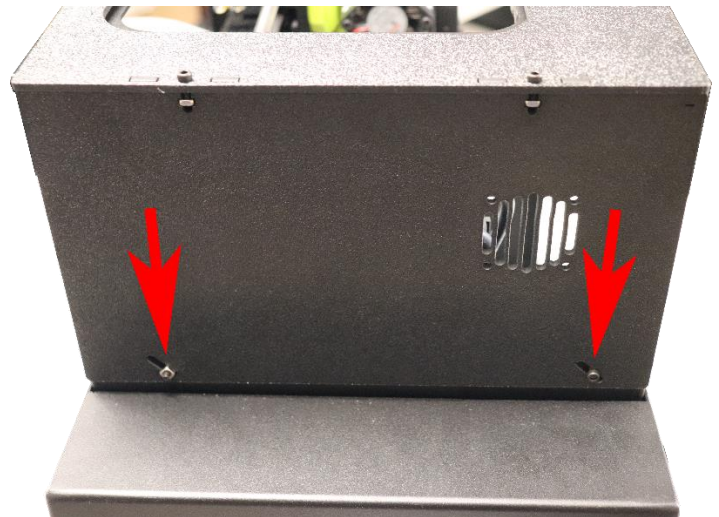
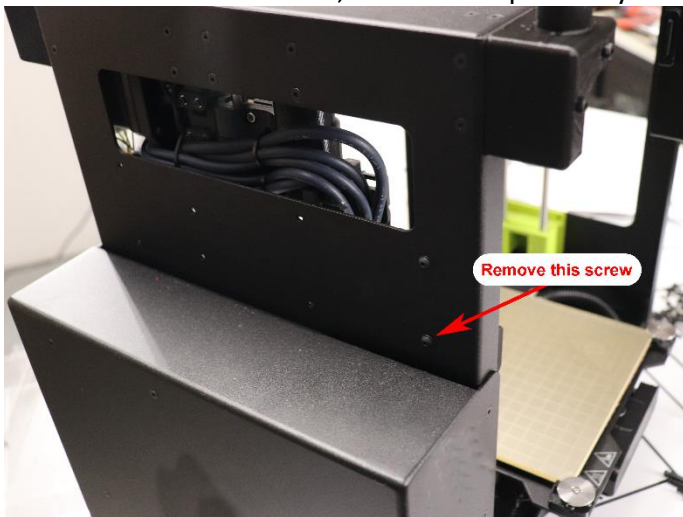

## Step 6:

Set the long side cover (Part J) on the right side of the printer by inserting the tabs into the slot on the top cover. Make sure that the spool holder slot is in line with the spool holder. The square nut sits in the slot and the 2 M3-10mm bolt goes through the top cover into the square nut. If you find it difficult to keep the nut in place while you insert the bolt you can use some painters tape to hold the nut in place for assembly. **DO NOT OVER TIGHTEN THE BOLTS.** Tighten them by hand and slightly more than 1/8<sup>th</sup> of a turn with a hex driver is enough to hold everything together.

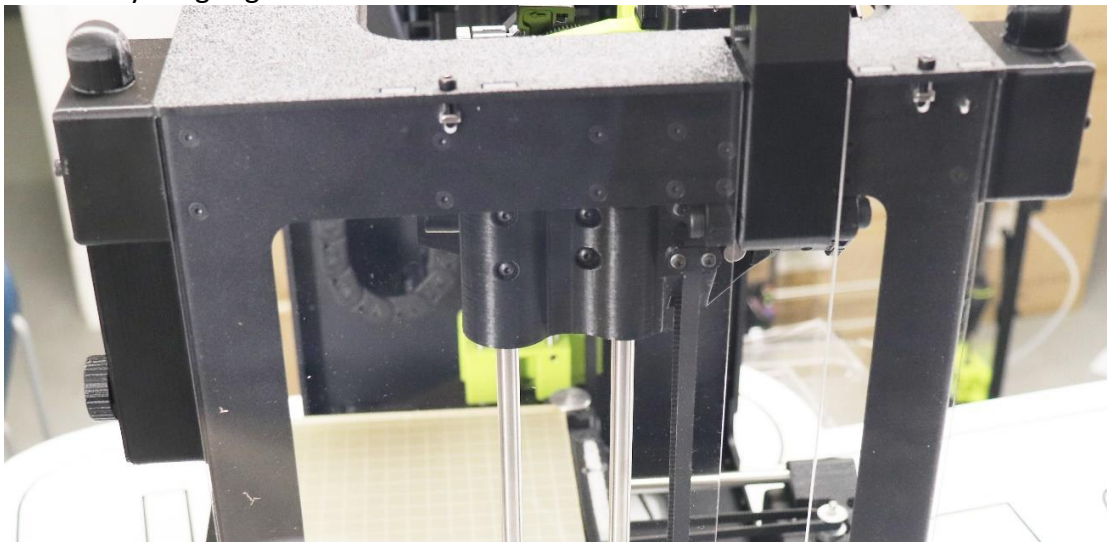

## Step 7:

Using 2 M3-10mm bolts, square nuts and washer you can insert these from the outside with the nut and washer on the inside of the 2 diagonal slots at the bottom of the long side cover (Part J). The washer and nut help to hold the lower portion on the frame of the printer.



## Step 9:

Take the black ABS front top cover with textured side up (Part F) and connect the 2 black ABS front side covers (Part E) using 2 M3-10mm bolts and M3 square nuts. Then connect the black ABS front bottom cover textured side up using 2 more M3-10mm bolts and M3 square nuts. If you find it difficult to keep the nut in place while you insert the bolt you can use some painters tape to hold the nut in place for assembly.

## Step 10:

Set the front panel with the Lulzbot logo (Part A) on top with the logo in the upper right corner. The 8 square nut sits in the slot on the sides/top/bottom and the 8 M3-10mm bolt goes through the top panel into the 8 square nut. If you find it difficult to keep the nut in place while you insert the bolt you can use some painters tape to hold the nut in place for assembly. **DO NOT OVER TIGHTEN THE BOLTS.** Tighten them by hand and slightly more than 1/8<sup>th</sup> of a turn with a hex driver is enough to hold everything together.

## Step 11:

Repeat steps 9 and 10 for the back cover using parts A / B / C / D

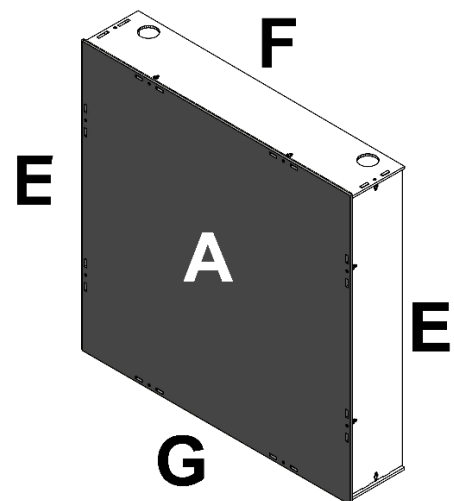
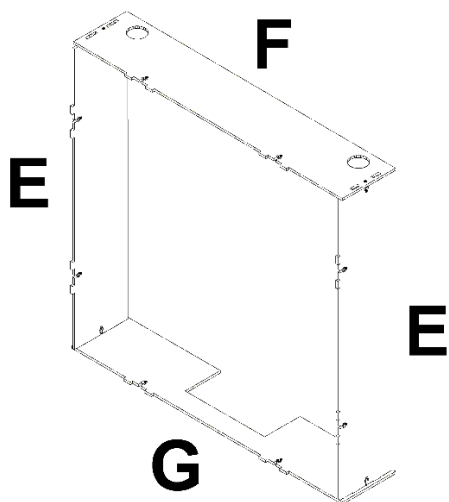

## Step 12:

While not needed we have included the optional plate cover (Part H) that sets in place to help cover the top. During our testing we saw no significant air flow or temperature differences in the printer with the optional top on or off. When using larger dimension spools of filament, removing the optional top cover can help prevent unnecessary drag. On some Mini's you may notice a slight lift of the optional plate cover when at max Z travel. This is normal and will not cause any damage to the printer.



## Proper Usage:

You can lift the front or back up and off the 3D printed post. The cutout on the bottom helps to clear the arms on the bed of the printer. It is normal for the cover to sit on the table and is part of the design to help reduce the risk of accidental breakage of the top plates. You will also notice the post holes are slightly enlarged and the front/back covers are slightly larger than the top and side covers. This is intentional to help prevent accidental snags or breakage after repeated use.

# Congratulations on a job well done!

*All product and company names are trademarks™ or registered® trademarks of their respective holders. Use of them does not imply any affiliation with or endorsement by them.*

*LulzBot® is a registered trademark of Fargo Additive Manufacturing Equipment 3D*

