

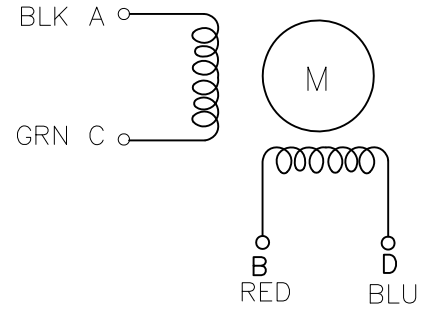

DIAGRAM



Label by laser print



LDOMOTORS.COM

1.8° Hybrid Stepper Motor 

LDO-42STH25-1004AC #YYMMDD

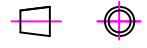
Items	Specs	Items	Specs					
Phase Number	2 phases	Step Angle	1.8° ±0.09°					
Rated Voltage	DC 11.8V	Rated Current	DC 1 A / Phase	A	---	New Release	SD XU J. B. 12/5/18	
Resistance(20°C)	11.8±10% Ω / phase	Inductance	11±20% mH / Phase	REV	ECN NO	Description	Made by Approve Date	
Holding Torque	≥240mN.m	Detent Torque	10mN.m REF.				LDO MOTORS CO.,LTD	
Rotate Direction	A-AB-B- CW	MAX Starting PPS	1300 PPS					Scale
MAX slewing PPS	≥ 1600 PPS	Insulation Resistance	≥ 100 MΩ (DC 500V)					
HI POT	AC600V/1mA/1S	Insulation Class	Class B					
Rotor Inertia	34 g.cm²	Weigth	0.152 Kg REF.	Des.	Check	Appr.	Date	
							Factory Code	page