

HT Stepper: (180 °C)

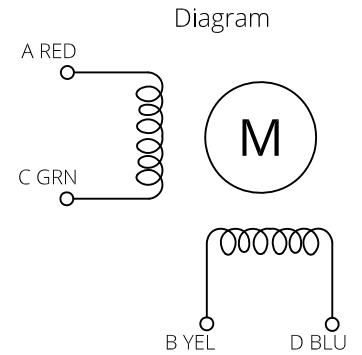
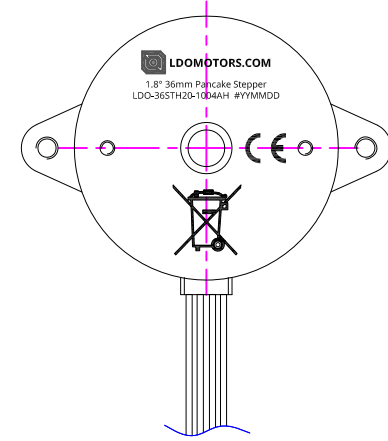
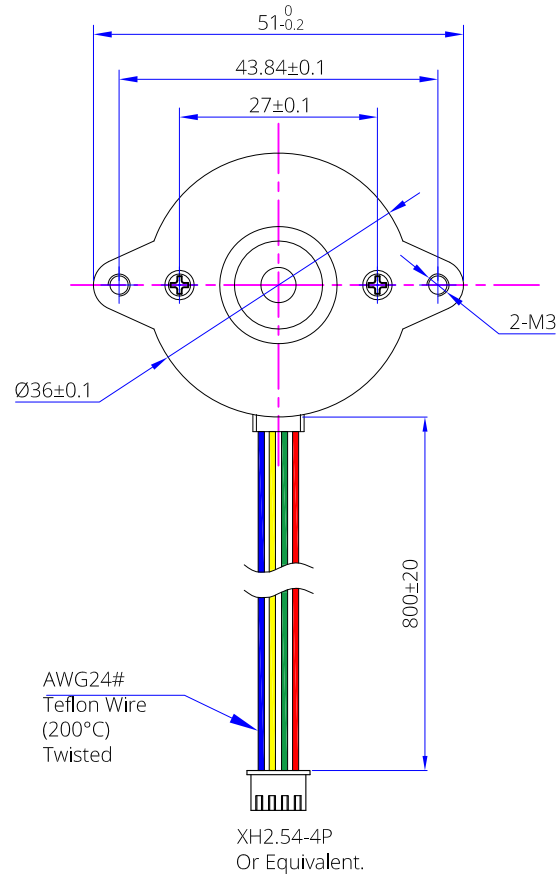
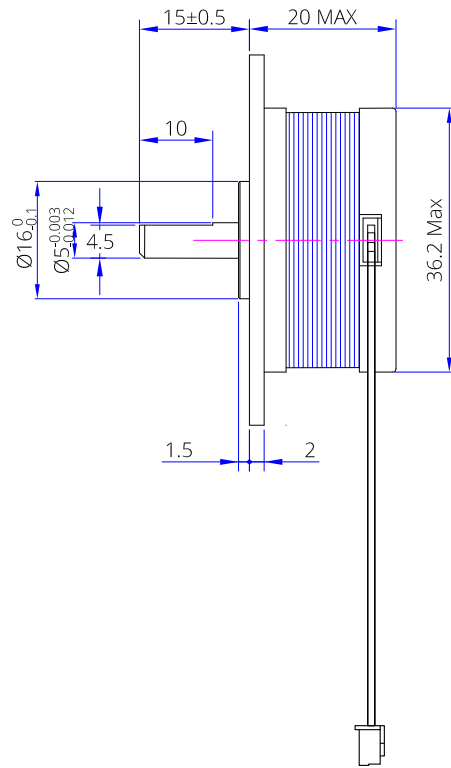

Item	Specification	Item	Specification
Phase Number	2	Step Angle	1.8° ± 5%
Rated Voltage	DC 2.1V / Phase	Rated Current	DC 1.0A / Phase
Phase Resistance	2.1x(1±10%) Ω	Phase Inductance	1.2x(1±20%) mH
Holding Torque	100mN-m MIN	Detent Torque	5 mN-m REF.
Rotate Direction	ACBDA CW	Insulate Resistance	100Mohm(DC500V)
HI-POT	AC600V/1mA/1S	Insulation Class	Class H 180°C
Rotor Inertia	16 g-cm ² REF	Weight	85 g REF

A		NEW RELEASE		Xu SD	J.B.	3/5/21
REV.	ECN NO.	DESCRIPTION		MADE BY	APPR. BY	DATE
		VIEW	LDO Motors Co., Ltd.			
		SCALE	Part NO. 1.8° 36mm Round Pancake Stepper LDO-36STH20-1004AH			
DRAWN BY	CHECKED BY	APPR. BY	DATE	FACTORY CODE	SHEET NO.	
Xu SD	J.B.	J.B.	3/5/21		1/1	