



Komeo

The water treatment unit Komeo descales water systems and purifies the water supply. It is the complete solution that ensures both house protection and optimum drinking water quality through a single unit.

Operating principle

Komeo combines an anti-scaling action with the filtering of micro-pollutants substances and the neutralising of bacteria, without any chemical treatment whatsoever. Komeo's electronic anti-scaling action neutralises calcium by eliminating its scaling properties while conserving its original mineral content (without excess sodium or insufficient calcium). The Stream self-cleaning preliminary filter traps the particles in suspension in the water, prevents the filters from clogging quickly and extends their life cycle. The power-operated valve purges the preliminary filter automatically without removing cartridges. Two activated carbon cartridge filters trap both heavy metals and micro-pollutants present in the water. They trap excess manganese and iron, and reduce the nitrates content. They also eliminate the bad taste of chlorine. The UVc lamp neutralises bacteria and viruses. Komeo's flow and pressure sensors detect leaks and provide real-time water consumption*, network pressure and consumables status data.



Advantages

- **Protects** pipe systems and household electrical appliances from scaling.
- **Eliminates** the bad taste of chlorine.
- **Provides** optimum drinking water quality.
- **Guarantees** water free of bacteria**.
- **Filters** pesticides and herbicides, heavy metals and manganese.
- **Reduces** the presence of nitrates.
- **Ecological**, with no chemical treatment or release of salts.
- **Detects** water system leaks.
- **Remote control** facility (through the tablet or smart phone application).



Fields of application

Komeo is the ideal solution to treat water in a private house or apartment. Its maximum rating of 2 m³/h is sufficient to supply the equivalent of two showers and one water tap simultaneously. Komeo can meet the water requirements of a household of up to 6 persons.

* Data provided by the flow meter is only a guide and must not be used for the purposes of contractual water metering.

** Komeo neutralises 99.99% of the micro-organisms incidentally present in the water.



Specifications

Electronic parts

- Scaling inhibitor by electrical fields with 2 treatment ratings. Technology Rimeau AteX CST Bat. No. 575 – 05/1995.
- UVc treatment chamber, stainless steel. Lamp 25 W.
- Water quality standard: optimum operation of UVc lamp assured up to an instantaneous flow rate of 1.5 m³/h, with minimum 25 mJ/cm² in accordance with the DDASS (French Authority) directive of 19/01/1987.
- Electricity consumption slaved to water utilisation by an integral flow sensor (auto-standby function).
- Touch screen 3.5" TFT. Resolution 320x240 pixels.
- Wi-Fi transmitter 2.4 GHz single band, IEEE 802.11 b/g/n.
- Power valves on inlet and preliminary filter.
- Pressure sensors and flow meter.
- Electrical supply required: 230 V AC 50-60 Hz single phase mains power supply + earth.
- Protection (waterproofing): IP 20.
- Electrical standard: CE compliant.
- Fuse: T 1 AT (5*20).

Hydraulic parts

- Self-cleaning Stream preliminary filter with 2 levels: 90 µm and 40 µm on stainless mesh.
- Cartridge filter 10 µm, based on BIRM® combined with extruded activated carbon: treatment of chlorine, iron and manganese, and reduction of nitrates.
- Cartridge filter 10 µm, based on KDF® combined with extruded active carbon: treatment of heavy metals and micropollutants
- Maximum water system pressure: 4 bars.
- Water temperature: 5 to 30 °C.
- Maximum water flow rate: 2 m³/h.
- Maximum hardness: up to 45°F or 25°dH.
- Inlet/outlet ¾" male (or female through angle unions supplied).
- Integral air purge on heads.
- Water purge for pressure release.
- Dimensions cm (H x W x D): 59 x 59 x 17.
- Weight: 20 kg.

Product name	Reference
Komeo	Q412005001

- | | |
|--|-------------------------------|
| 1. Inlet and outlet unions | 9. Power supply cable |
| 2. Flow meter chamber - Anti-scaling – Power inlet valve | 10. 4 batteries pack |
| 3. Preliminary filter | 11. Preliminary filter wrench |
| 4. Motor-operated valve | 12. Filter wrench |
| 5. 15" filter bowls | 13. Water purge |
| 6. Filter nuts | 14. Touch screen |
| 7. UVc lamp connector | |
| 8. Antibacterial UVc chamber | |

Installation

Komeo is installed against a wall and is connected directly to the incoming water supply, to treat the water for the entire household. The unit can be installed in less than one hour, using the drilling template and the simple installation manual. There is no start-up phase, once connected, Komeo starts treating water immediately.

Maintenance

Komeo automatically informs the user of the condition of the filters and the UVc lamp, through the touch screen interface or *via* the remote control application. The accessibility and replacement of these elements are simplified by an automatic cut-out of Komeo when the unit is opened and through an integrated tutorial. Depending on the volume and quality of the water being treated, the filter cartridges should be changed on average every year, and the UVc lamp every year and a half.

Guarantee

Three years, parts and labour – excluding consumables or transport expenses.

Spare parts

Product name	Reference
Filter cartridge 10 µm 15" BIRM®	Q511016001
Filter cartridge 10 µm 15" KDF®	Q511015001
25 W UVc lamp	Q512013001
Seals kit for quartz tube	Q513010001
Self-cleaning preliminary filter mesh	Q511017001
O-ring for filter housing	527199

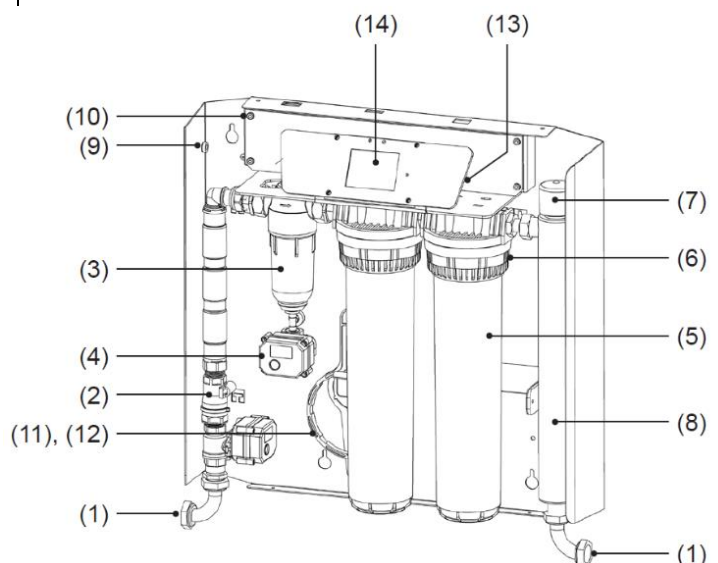

COMAP Water Treatment

ZA les Petits Champs - 26120 MONTÉLIER –France

E-mail: comapwt@comap.eu | Website: www.comapwt.com | Customer support: Tel. +33 4 75 85 28 11 - Fax +33 4 75 85 42 62