



ITT

Wastewater

Goulds Pumps

WS_D4 Series Model 3888D4

Submersible Sewage Pump



FEATURES

- **Impeller:** Cast iron, two vane semi-open, non-clog with pump-out vanes for mechanical seal protection. Balanced for smooth operation. Silicon bronze impeller available as an option.
- **Casing:** Heavy duty gray cast iron, ASTM A48, Class 30. Volute type casing with 4", 125#, ANSI flanged, horizontal discharge. Compatible with A10-40 cast iron or A10-40B cast iron and brass (non-sparking) guide rail assembly.
- **Dual Mechanical Seals:** Silicon carbide vs. silicon carbide outer seal and ceramic vs. carbon inner seal, stainless steel metal parts, BUNA-N elastomers. Upper and lower shaft seals are positioned independently and are separated by an oil-filled chamber.
- **Shaft:** 300 series stainless steel keyed design.
- **Fasteners:** 300 series stainless steel.
- Capable of running dry temporarily without damage to seals or motor.



Goulds Pumps is a brand of ITT Water Technology, Inc.
- a subsidiary of ITT Industries, Inc.

www.goulds.com

Engineered for life

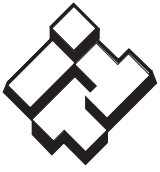

ITT

GOULDS PUMPS Wastewater

APPLICATIONS

Used in a variety of residential, commercial and industrial applications such as:

- Sewage systems, Flood and Pollution Control, Dewatering/Effluent, Farms, Hospitals, Trailer Courts, Motels

SPECIFICATIONS

Pump:

- Maximum solid size: 3"
- Discharge size: 4", 125 # ANSI flange
- Maximum capacity: 620 GPM
- Maximum total head: 60 feet
- 300 Series stainless steel fasteners
- 20' Power cord
- Standard silicon carbide/silicon carbide outer seal

Motor:

- Maximum ambient temperature: 104° F (40° C) continuous duty, 140° F (60° C) intermittent duty
- Rated for continuous duty when fully submerged
- Insulation: Class F
- 60 Hertz
- Single row ball bearings
- 300 Series stainless steel keyed shaft

Single Phase:

- 1.5 - 5 HP; 208 and 230 volts
- Built-in thermal overloads with automatic reset
- Built-in capacitors

Three Phase:

- 1.5 - 7.5 HP; 200, 230, 460 and 575 volts
- Class 10 overload protection must be provided in control panel

MOTORS

- Fully submerged in oil-filled chamber. High grade turbine oil surrounds motor for more efficient heat dissipation, permanent lubrication of bearings and mechanical seal for complete protection against outside environment.
- **Class F insulation.**
- **Designed for Continuous Operation:** Pump ratings are within the motor manufacturer's recommended working limits and can be operated continuously without damage when fully submerged.
- **Bearings:** Upper and lower heavy duty ball bearing construction for precision positioning of parts and to carry thrust loads.
- **Power Cable:** Severe duty rated, oil and water resistant. Epoxy seal on motor end provides secondary moisture barrier in case of outer jacket damage and to prevent oil wicking. 20 foot standard with optional lengths available.
- **O-ring:** Assures positive sealing against contaminants and oil leakage.

AGENCY LISTINGS

 Tested to UL 778 and CSA 22.2 108 Standards
By Canadian Standards Association File #LR38549
Us Goulds Pumps is ISO 9001 Registered.

MODEL AND MOTOR INFORMATION

Order No.	HP	Phase	Volts	RPM	Impeller Dia. (in.)	Maximum Amps	L.R. Amps	KVA Code	Power Cable	F.L. Motor Efficiency %	Resistance		Wt. (lbs.)		
											Start	Line-Line			
WS1518D4M	1.5	1	208	1750	5.63	17.2	50.8	B	14/3	80	1.1	0.9	195		
WS1512D4M			230			14.7	29.5	E		70	1.4	1.8			
WS1538D4M		3	200			11.5	40.9	H	14/4	81	NA	83		1.7	2.3
WS1532D4M			230			10.0	40.0	F		83		9.3			
WS1534D4M			460			5.0	20.0	F		83		14.8			
WS1537D4M			575			4.0	14.4	H		74					
WS1518D4	1.5	1	208	1750	6.25	17.2	50.8	B	14/3	80	1.1	0.9	195		
WS1512D4			230			14.7	29.5	E		70	1.4	1.8			
WS1538D4		3	200			11.5	40.9	H	14/4	81	NA	83		1.7	2.3
WS1532D4			230			10.0	40.0	F		83		9.3			
WS1534D4			460			5.0	20.0	F		83		14.8			
WS1537D4			575			4.0	14.4	H		74					
WS2018D4	2	1	208	1750	6.63	20.3	50.8	B	14/3	80	1.1	0.9	200		
WS2012D4			230			17.3	36.9	D		75	1.4	1.5			
WS2038D4		3	200			13.3	40.9	H	14/4	81	NA	83		1.7	2.3
WS2032D4			230			11.6	40.0	F		83		9.3			
WS2034D4			460			5.8	20.0	F		83		14.8			
WS2037D4			575			4.6	14.4	H		74					
WS3018D4	3	1	208	1750	7.00	25.5	50.8	B	10/3	80	1.1	0.9	208		
WS3012D4			230			21.5	46.4	C		79	1.0	1.0			
WS3038D4		3	200			16.6	53.8	G	14/4	85	NA	83		1.3	1.9
WS3032D4			230			14.4	49.5	H		83		7.5		11.6	
WS3034D4			460			7.2	24.8	H		83					
WS3037D4			575			5.8	17.3	G		78					
WS5012D4	5	1	230	1750	7.25	26.5	57.7	A	10/3	80	1.0	0.8	213		
WS5038D4			200			19.1	73.9	F		84	0.9	1.2			
WS5032D4		3	230			16.6	63.6	E	14/4	85	NA	85		4.8	7.4
WS5034D4			460			8.3	31.8	E		85					
WS5037D4			575			6.6	22.8	E		80					
WS7532D4			230			23.0	105.0	G		83		0.7		2.8	
WS7534D4	7.5	3	460	1750	7.69	11.5	52.5	G	10/4	83	NA	4.4	225		
WS7537D4			575			9.2	42.0	E		84					

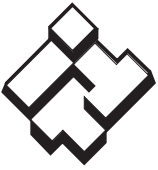

ITT

GOULDS PUMPS Wastewater

MATERIALS OF CONSTRUCTION

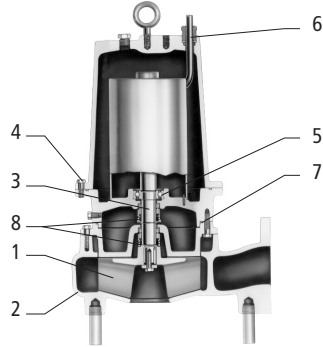

Item No.	Part Name	Material				
		Standard	Optional			
1	Impeller, non-clog	1003	1179			
2	Casing	1003				
3	Shaft-keyed	300 Series SS				
4	Fasteners	300 Series SS				
5	Ball bearings	Steel				
6	Power cable	STOW, 20 feet	Additional lengths			
7	O-ring	BUNA-N				
8	Outer Mech. Seal	Service	Rotary	Stationary	Elastomers	Metal Parts
	OPT	Heavy duty	Silicon Carbide	Tungsten Carbide	BUNA-N	300 Series SS
	STD	Mild abrasives	Silicon carbide		BUNA-N	300 Series SS
Material Code		Engineering Standard				
1003		Cast iron — ASTM A48 Class 30				
1179		Silicon bronze — ASTM C87600				

PERFORMANCE RATINGS (Gallons Per Minute)

Series No. ▶	WS15D4M	WS15D4	WS20D4	WS30D4	WS50D4	WS75D4	
HP ▶	1½	1½	2	3	5	7½	
RPM ▶	1750						
Total Head Feet of Water	10	300	395				
	15	170	320	370			
	20		230	300	440	520	
	25		120	205	365	440	
	30			100	270	360	510
	35				160	275	440
	40				80	175	355
	45					85	260
	50						155
	55						80

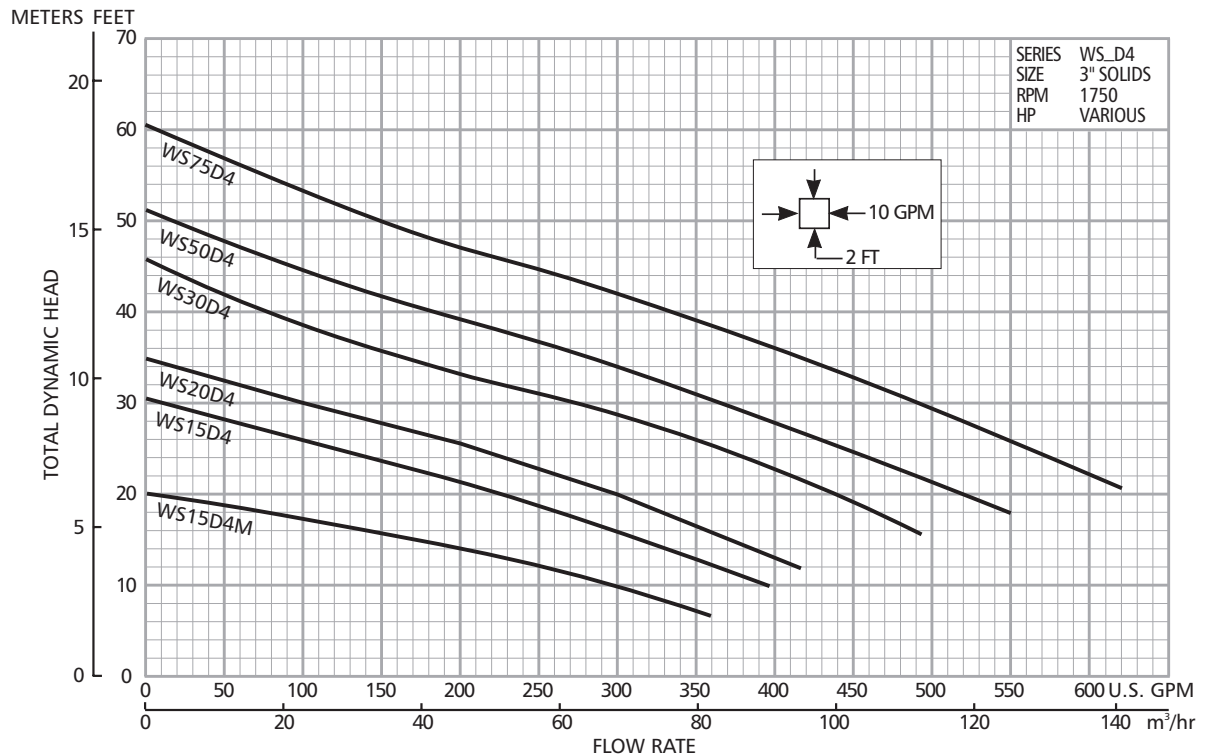

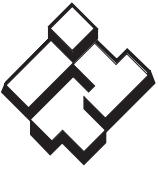

ITT

Wastewater

APPLICATION DATA AND CONSTRUCTION DETAILS

Maximum Solid Size	3"	
Minimum Casing Thickness	5/16"	
Casing Corrosion Allowance	1/8"	
Maximum Working Pressure	30 PSI	
Maximum Submergence	50 feet	
Minimum Submergence	Fully submerged for continuous operation 6" below top of motor for intermittent operation	
Maximum Environmental Temperature	40° C (104° F) continuous operation, 60° C (140° F) intermittent operation	
Power Cable – Type (See Motor Information for AWG data/size.)	Type SJTOW: single phase, 1½ and 2 HP Type STOW: single phase, 1½ – 3 HP and 5 HP, 460 V Type STOW: single phase, 3 and 5 HP, three phase 5 HP, 230 V and 7½ HP	
Motor Cover, Bearing Housing, Seal Housing, Casing	Gray Cast Iron – ASTM A48, Class 30	
Impeller – Standard, Optional	Gray Cast Iron – ASTM A48 or Cast Bronze – ASTM B584 C87600	
Motor Shaft	AISI 300 Series Stainless Steel	
Motor Design	NEMA 56 Frame, oil filled with Class F Insulation	
Motor Overload Protection	Single phase: on winding thermal overload protection auto reset Three phase: requires Class 10 overloads in control panel	
External Hardware	300 Series Stainless Steel	
Impeller Type	Semi-open with pump out vanes on back shroud	
Oil Capacity – Seal Chamber	1.5 quarts	
Oil Capacity – Motor Chamber	1½-5 HP single and three phase: 7 quarts 7½ HP three phase: 6.5 quarts	
Mechanical Seals – Standard	Upper	Carbon/Ceramic; Type 21
	Lower	Silicon Carbide/Silicon Carbide; Type 31
Mechanical Seals – Optional Lower	Silicon Carbide/Tungsten Carbide; Type 31	

DIMENSIONS

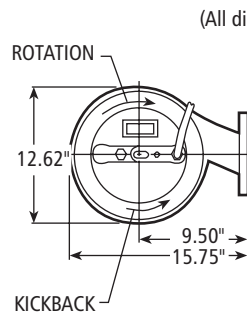
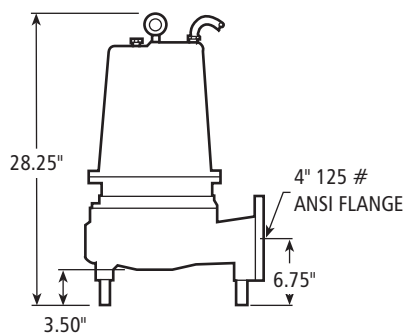

(All dimensions are in inches. Do not use for construction purposes.)



Goolds Pumps and the ITT Engineered Blocks Symbol are registered trademarks and tradenames of ITT Industries Inc.

SKF is a registered trademark of Aktiebolaget SKF, Sweden.

SPECIFICATIONS ARE SUBJECT TO CHANGE WITHOUT NOTICE.

B3888D4 March, 2006

© 2006 ITT Water Technology, Inc.

Engineered for life