

Condition Monitoring Pod™

Installation Instructions

Components

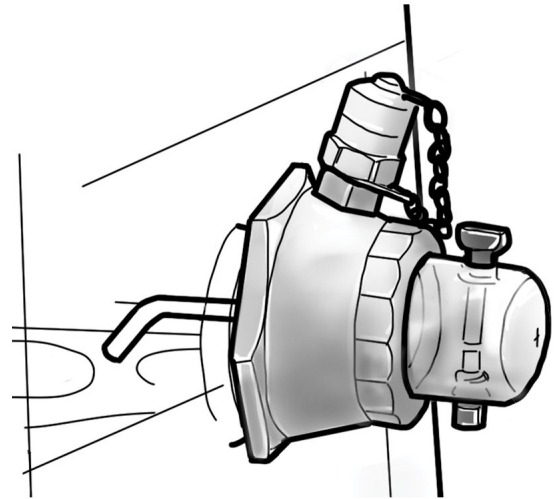
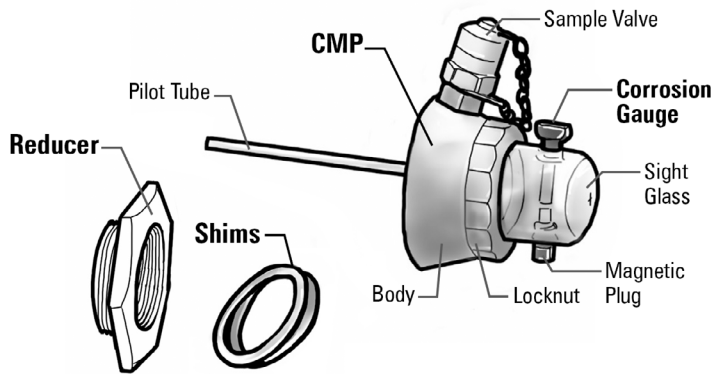

Required Tools

- Tube bender for $\frac{3}{16}$ ", $\frac{1}{4}$ " or 5mm diameter tube. Tube bender style sold on LUNETA.COM recommended.
- Wrench for 2.75" wide hex
- Thread sealing compound or tape
- Oil rags
- Oil pan or bucket for catching any oil during installation

LUNETA
SMART PRODUCTS • RELIABLE MACHINES

View instructional videos demonstrating the versatility of the Condition Monitoring Pod at Luneta.com

How to Use

The new Condition Monitoring Pod (CMP) is a multi-parameter inspection device modernizing and expanding the power of daily lubricant inspections. CMP boasts a robust platform of 16 capabilities including:

- An oil sampling valve
- Easy-to-remove-and-view Magnetic Plug
- Corrosion/varnish inspection probe
- Quick lubricant access point for syringe sampling

Please reference our company website at Luneta.com for additional product details and to view **instructional videos** demonstrating the versatility of this time saving device!

Prior to Installation

It is important prior to installation to check that the inside of the CMP does not contain any debris. If debris is present, use compressed air to remove. If ferrous debris is on magnet, unthread magnet and wipe clean. Do not remove Locknut or Sight Glass.

It is important to ensure that the pilot tube is bend down into the oil and that the sampling port is oriented at a convenient angle for sampling. Please follow the installation instructions to achieve this correct orientation.

Do not remove Locknut and Sight Glass unless for cleaning. If removed, hold Sight Glass tightly against CMP Body while threading the Locknut to ensure the O-Ring is properly seated. If not done properly there is a chance the O-Ring will become damaged and/or the Locknut threads will jam.

Warnings and Disclaimers

- For use on center-line oil level ports only; sight glass should not be filled above the cross-hair marking on the CMP during running conditions
- For use with mineral and synthetic oils compatible with fluorocarbon elastomers (Viton) and acrylic plastic
- Do not use on pressurized systems
- Not for use on moving vehicles
- Do not use on moving machine surfaces (e.g., reciprocate, oscillating or rotating) or machines exposed to shock or fluid surge conditions
- Do not use on machines with oil temperatures outside the range of -20 °F (-29°C) to 200 °F (94°C).
- Do not use on machines with ambient temperatures below -20 °F (-29°C)
- Do not use cleaning solvents incompatible with acrylic plastic or fluorocarbon elastomers (Viton)
- Install the CMP on machine port locations that are a safe distance from moving machine parts, vehicles and or foot traffic
- Do not stand on the CMP
- Do not use or add an additional thread-reducer bushing other than the one shipped with the CMP. This will result in errors in oil level measurement.
- Luneta, LLC not responsible for damages associated with incorrectly installing the CMP or for improper use as outlined in this manual and on the website Luneta.com.

INSTALLATION INSTRUCTIONS

STEP 1 – Identify Appropriate Location

Identify a port hole on your machine that is positioned at the oil level. Do not install CMP below oil level or on pressurized systems.

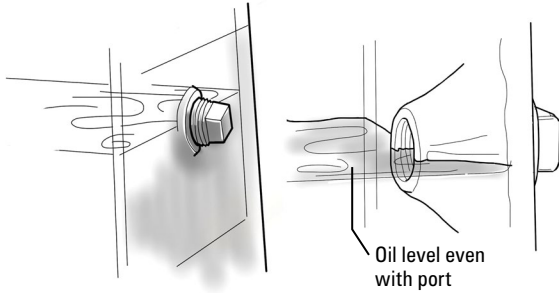

STEP 2 – Drop Oil Level

Drop oil level in the machine below the port hole to prevent spillage during CMP installation.

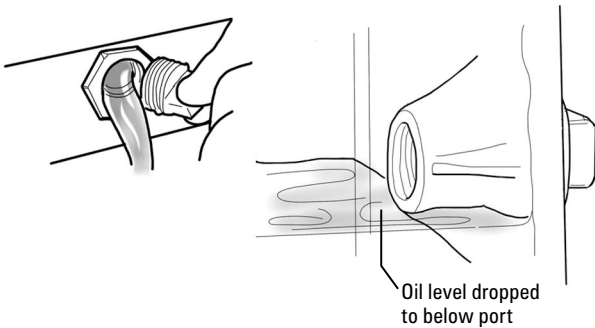

STEP 3 – Install Reducer

Tightly thread the Reducer into the port hole of your machine using a wrench and thread sealer.

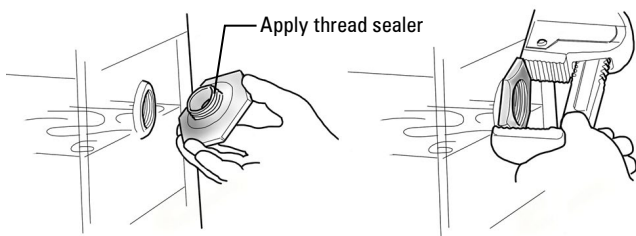

STEP 4 – Check Sample Valve Orientation

Hand thread the CMP into Reducer. If the Sampling Port is not at a convenient location when fully tightened, use the supplied shims between the Reducer and CMP to reorient the Sampling Port. Note the down direction for bending the Pilot Tube.

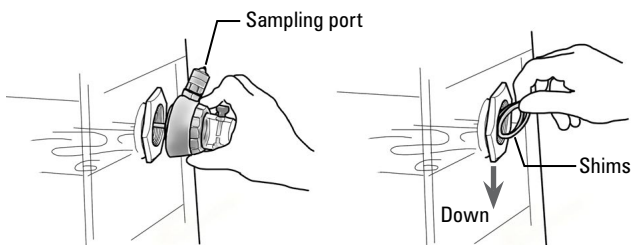

STEP 5 – Bend Pilot Tube

Unthread the CMP from the Reducer and using the appropriate Tube Bender, bend the Pilot Tube down in the direction noted in previous step. Choose a bend location and angle which best places the tip of the Pilot Tube within your machine for good sampling.

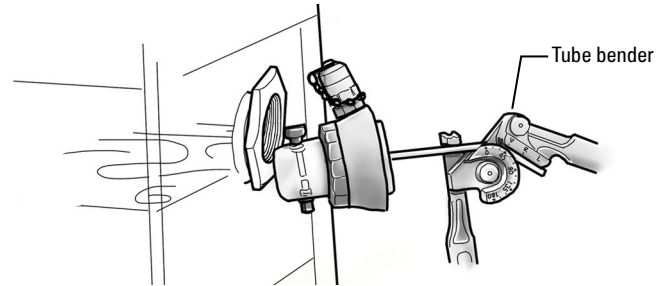

STEP 6 – Install CMP

Tightly thread the CMP into the Reducer using pipe sealer. If Shims were required, don't forget to install these at the same time. **Tip:** Use the Sampling Port as leverage to achieve enough torque.

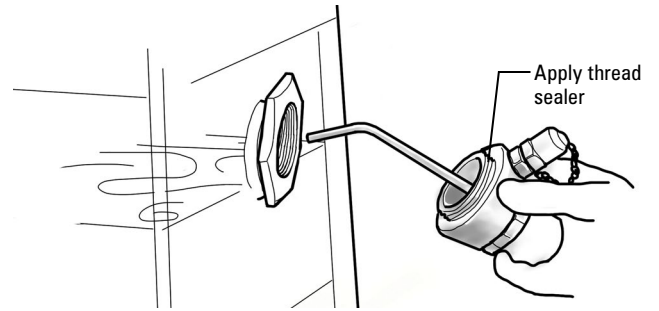

STEP 7 – Correct Sight Glass Orientation

Thread the Corrosion Gauge into the Sight Glass port opposite the Magnetic Plug. Loosen the Locknut and rotate the Sight Glass so that the Magnetic Plug is at the bottom and the Corrosion Gauge is at the top. Hand tighten the Locknut. **Note:** Do NOT use thread sealer or threadlocker on the Locknut. And DO NOT remove Locknut and Sight Glass unless for cleaning.

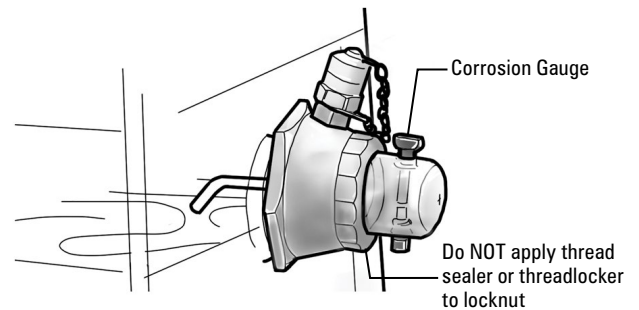

STEP 8 – Add Oil

Check that all threaded components are tight and then replenish the machine with oil so that the oil is level with the cross hairs on the Sight Glass.

