

New TFORCE Owner's Manual



READ THIS MANUAL CAREFULLY! It contains important safety and service information.

★ ★ ★ ★ ★ ★ ★ ★ ★ ★
VMC
CHINESE PARTS
YOUR 10 STAR PARTS CONNECTION
ATVs - Go Karts - Scooters - Dirt Bikes -UTVs
vmchineseparts.com - 618-529-2593

Please read carefully before operating this vehicle!



WARNING

This vehicle should only be assembled and prepped by an authorized Tao Motor Dealer or professional motorcycle mechanic. You should never try or attempt assembly of this vehicle; it should be done by professionals. Death or serious injury could result from failure to follow these warnings and instructions.

WARNING: Operating, servicing and maintaining a passenger vehicle or off-highway motor vehicle can expose you to chemicals including engine exhaust, carbon monoxide, phthalates, and lead, which are known to the State of California to cause cancer and birth defects or other reproductive harm. To minimize exposure, avoid breathing exhaust, do not idle the engine except as necessary, service your vehicle in a well-ventilated area and wear gloves or wash your hands frequently when servicing your vehicle. For more information go to www.P65Warnings.ca.gov/passenger-vehicle.

TIP

INTRODUCTION

Thank you for purchasing the New TFORCE. This ATV is designed for years of reliable use and family fun. This manual will provide you with a good basic understanding of the features and operation of this ATV.

This manual includes important safety information. It also includes general riding techniques, maintenance and inspection procedures. If you have any questions regarding the New TFORCE, please contact your local Tao Motor dealer, visit www.taomotor.com or call Customer Service at 214-635-3980.

AN IMPORTANT NOTE TO PARENTS:

WARNING

THE New TFORCE IS INTENDED FOR USE BY OPERATORS 10 YEARS OF AGE AND OLDER. This ATV is not a toy. Before you let your child operate this ATV, you should understand the instructions and warnings in this Owner's Manual. Then be sure your child understands and will follow them. Children differ in skills, physical abilities and judgment. Some children may not be able to operate an ATV safely. Parents should supervise their child's use of the ATV at all times. Parents should permit continued use only if they determine that the child has the ability to operate this ATV safely.

The New TFORCE has multiple safety features including an adjustable speed limiter. We recommend that all beginners start with the slowest setting first. The speed adjusting screw may be gradually turned out as the beginner becomes more familiar with operating this ATV. Parents should decide when to adjust for more power and speed as the rider's riding skills improve.

TIP

As a new owner of this vehicle, the ATV owner/driver and immediate family of this vehicle can enroll in a free hands-on training course. New purchasers of any new Tao Motor ATV models by calling (855) 717-8618.

IMPORTANT MANUAL INFORMATION



WARNING

FAILURE TO FOLLOW THE WARNINGS CONTAINED IN THIS MANUAL CAN RESULT IN SERIOUS INJURY OR DEATH.

Important information is distinguished in this manual by the following notations:



This is the safety alert symbol. It is used to alert you to potential personal injury hazards. Obey all safety messages that follow this symbol to avoid possible injury or death.



WARNING

A WARNING indicates a hazardous situation which, if not avoided, could result in death or serious injury.

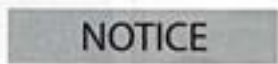

NOTICE

A NOTICE indicates special precautions that must be taken to avoid damage to the vehicle or other property.

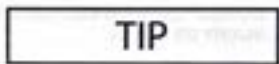

TIP

A TIP provides key information to make procedures easier or clearer.

Product and specifications are subject to change without notice.

IMPORTANT NOTICE



WARNING

The New TFORCE ATV is designed and manufactured for off-road use only. It is illegal and unsafe to operate this ATV on any public street, road or highway.

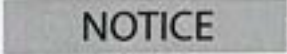

NOTICE

This ATV complies with all applicable off-road noise level and spark arrester laws and regulations. Please check your local riding laws and regulations before operating the New TFORCE ATV.



WARNING

This ATV should not be operated by anyone under 12 years of age.

WARNING & SAFETY LABELS

Please read and understand all of the labels on your New TForce. These labels contain important information for safe and proper operation. Never remove any labels from your ATV. If a label becomes difficult to read or comes off, request a new replacement label from your local Tao Motor dealer.

▲ WARNING

Improper use of ATVs can cause SEVERE INJURY OR DEATH.



ALWAYS USE AN APPROVED HELMET AND PROTECTIVE GEAR



NEVER USE ON PUBLIC ROADS



NEVER CARRY PASSENGERS



NEVER USE WITH DRUGS OR ALCOHOL

NEVER operate:

- without proper training or instruction
- at speeds too fast for your skills or the conditions
- on public roads - a collision can occur with another vehicle
- with a passenger - passengers affect balance and steering and increase risk of losing control

ALWAYS:

- use proper riding techniques to avoid vehicle overturns on hills and rough terrain and in turns.
- avoid paved surfaces - pavement may seriously affect handling and control

LOCATE AND READ OWNER'S MANUAL. FOLLOW ALL INSTRUCTIONS AND WARNINGS.

▲ WARNING

Improper tire pressure or overloading can cause loss of control. Loss of control can result in severe injury or death.

OPERATING TIRE PRESSURE - Set with tires cold

Recommended	Front	15 psi (104kpa)
	Rear	15 psi (104kpa)
Maximum	Front	18 psi (124kpa)
	Rear	18 psi (124kpa)
Minimum	Front	2 psi (13.70Kpa)
	Rear	2 psi (13.70Kpa)

Never set tire pressure below minimum. It could cause the tire to dislodge from the rim.

LOADING

Maximum Vehicle Load: 95 lbs (44.0kg)
Includes weight of operator, cargo and accessories.

▲ WARNING



NEVER ride as a passenger.

Passengers can cause a loss of control, resulting in SEVERE INJURY or DEATH.

▲ WARNING



Operation of this ATV by children under the age of 12 increases the risk of severe injury or death.

Adult supervision required for children under age 12.

NEVER permit children under age 12 to operate this ATV.

This Vehicle is subject to the Tao Motor ATV action plan and this vehicle is compliant with the ANSI/ISO 12010 standard and any successor standards adopted by the CPSC for ATVs ("the ATV Standard").



▲ CAUTION

Maximum Carrying Capacity Of This Cargo Rack is 50kg / 110lbs

TABLE OF CONTENTS

Engine Stop, Lanyard Cord & Remote	1,2	Gear Selector Lever.....	24
Transporting	3	Throttle Cable & Throttle Cable Adjustment	25
Description	4	Front Brake Lever	26
Instrument Cluster	7	Front Brake Lever Freeplay Lower adjustment.....	27
Control Layout	5	Hydraulic Rear brake & Foot Brake	27,28
Main Switch.....	6	Engine Idle Adjustment	29
Speed Limiter.....	8	Adjusting Suspension Spring Preload	30
Parking Brake	9	Maintenance	31
Choke Lever.....	10	Getting To Know Your ATV	32-42
Fuel Tank Capacity	11	Specification Chart	43
Fuel Tank Cap	12	Engine Hour Meter	44
Fuel Cock/Fuel Valve.....	13	Maintenance Chart	45-49
Seat	14	Engine Oil	50-51
Battery & Location	15	Cleaning Air Filter Element	52
Battery Charging & Changing Fuse.....	16	Spark Plug	53
Pre-Ride Safety Checks.....	17,18	Drive Chain & Adjustment	54-56
Front & Rear Brakes	19	Cleaning Spark Arrester	57
Wear Limits and Chassis Fasteners	20	Electrical Wiring Diagram.....	58
Starting Engine	21	Electrical Connector Wiring Diagram	59
Engine Break-In	22	Commonly Asked Questions	60
Parking, Accessories & Modifications, Rear Cargo Rack.....	23	Emission Control System Warranty	61-63

SAFETY INFORMATION

THE New TFORCE ATV IS NOT A TOY AND CAN BE HAZARDOUS TO OPERATE.

MAKE SURE YOU UNDERSTAND ALL INSTRUCTIONS.

PAY CLOSE ATTENTION TO THE WARNING AND CAUTION LABELS ON THE ATV.

NEVER OPERATE THIS ATV WITHOUT PROPER TRAINING OR INSTRUCTION.

CHILDREN MAY NOT BE ABLE TO OPERATE THIS VEHICLE SAFELY DUE TO PHYSICAL OR MENTAL LIMITATION.

NOTICE

The ATV you purchased may differ slightly from the illustrations in this Owner's Manual. Please consult your local Tao Motor dealer with any questions not covered in this manual.



SAFETY INFORMATION



Always avoid operating an ATV on any paved surfaces, including sidewalks, driveways, parking lots and streets. FOR OFF-ROAD USE ONLY.

This ATV is designed for operation by a single driver at least 10 years of age, without passengers.

Never operate an ATV on any public street, road or highway, even a dirt or gravel road. This ATV is designed and manufactured for Off Road use only no public roads.

Never operate an ATV without wearing an approved ATV/motorcycle helmet that fits properly. You should also wear eye protection (goggles or face shield), gloves, boots, a long-sleeved shirt or a jacket, and long pants.

Never consume alcohol or drugs before or while operating this ATV.

Never operate the ATV on hills too steep for the ATV or for your abilities. Practice on smaller hills before attempting larger hills.

Never modify an ATV through improper installation or use of accessories.

Never attempt wheelies, jumps, or other stunts.

Always conduct a pre-ride inspection and follow the proper maintenance schedule and procedures as shown in this manual.

Always keep both hands on the handlebars and both feet on the footrests of the ATV at all times when operation the vehicle.

Always follow proper procedures for turning as described in this manual. Practice turning at low speeds before attempting to turn faster speeds and never turn at excessive speeds.

Never let refueling be done by anyone other than an adult.



SAFETY INFORMATION (continued)

SAFETY INFORMATION



Never permit anyone other than an adult to start the ATV.

Drain gasoline from the fuel tank and carburetor prior to transporting the ATV. Also for storage over 48hrs.

The fuel tank and carburetor should be drained for any long periods of storage and for winter storage of the vehicle.

Caution the child and others near the vehicle not to get close to or touch any moving parts or any heated areas such as the engine and exhaust pipe.

Never let your child operate an ATV without close adult supervision (a child under 10 should not operate this ATV even with adult supervision).

Promptly correct your child if he or she begins to ride beyond his or her abilities and, if necessary, intervene by pulling the cord (lanyard) or press " Engine Stop  " on the wireless key fob to stop the engine).

If the child rides beyond his or her abilities, or rides in terrain that is too difficult, he or she may lose control of the ATV, causing an accident.

Introduce new riding situations slowly and make sure the riding areas do not exceed your child's skill level.

ENGINE STOP LANYARD CORD & REMOTE

The New TFORCE has two emergency-stop engine switches. The primary emergency engine shut off switch is the lanyard cord and the secondary is the wireless engine shut off key fob.

⚠ WARNING

The wireless engine shut off key fob has a limited range that varies in different conditions. **DO NOT RELY** solely on the key fob as the emergency engine shut off switch, especially during operator training.

KEY FOB:

The wireless engine shut-off is desired for use by an adult supervising the child operating the ATV. The wireless engine shut-off will work in the range of 50ft. If outside the range of the remote the remote will not stop the engine.

1. Test the range by turning on the ATV and walk 50 feet away and press the shut-off button on the wireless remote. The engine should stop running, if the engine continues to run, you may need to get closer or make sure there are no obstructions between the ATV and you.
2. Before using the wireless engine shut-off switch make sure the batteries in the remote are new and have a full charge. Low or dead batteries in the wireless remote can prevent the it from working properly.
3. The wireless engine shut-off key fob should not be used as a full-time engine stop switch by the operator.



TIP

Supervising adults can use the wireless engine shut-off switch to turn the engine off if the operator is riding recklessly or beyond his or her skill level. Once corrective instructions have been given, the adult can restart the engine using the wireless remote switch.

LANYARD CORD:

The lanyard cord is designed for use by an adult supervising the child operating the ATV. When using the engine stop switch cord, be sure the speed limiter on the handlebar is adjusted and the engine speed limits the ATV to a walking speed.

1. Install the cap on the end of the engine stop switch cord onto the engine shut-off switch (Red button).
2. Put your fingers in the loop at the other end of the cord.
3. As your child is riding, walk behind the ATV, closely watching his or her actions as well as the path ahead.
4. If there is a potential hazard ahead or if your child is not riding correctly, pull firmly on the cord (lanyard) to stop the engine. Because the ATV will continue to roll for some distance, allow extra time and distance to pull the cord before a potentially hazardous situation might be encountered.

NOTICE

The ATV will not start without the cap in place.

TIP

The lanyard assembly can be attached on the left or right side of the handlebar.

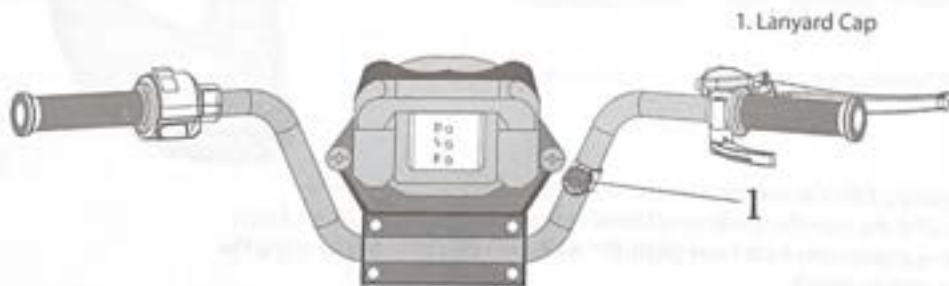

TRANSPORTING THE ATV

⚠ WARNING

Avoid Carbon Monoxide Poisoning! All engine exhaust contains carbon monoxide, a deadly gas. Breathing carbon monoxide can cause headaches, dizziness, drowsiness, nausea, confusion, and eventually death. Carbon Monoxide is a colorless, odorless tasteless gas which may be present even if you do not see or smell any engine exhaust. Deadly levels of carbon monoxide can collect rapidly and you can quickly be overcome and unable to save yourself. Also, deadly levels of carbon monoxide can linger for hours or days in enclosed or poorly ventilated areas.

If you experience any symptoms of carbon monoxide poisoning, leave the area immediately, get fresh air, and SEEK MEDICAL TREATMENT.

Do not run engine indoors. Even if you try to ventilate engine exhaust with fans or open windows and doors, carbon monoxide can rapidly reach dangerous levels.

Drain gasoline from the fuel tank and carburetor prior to transporting the ATV. Also for storage over 48hrs.

When transporting the ATV in another vehicle, be sure it is kept upright and that the fuel valve is in the off position. Fuel may leak out of the carburetor or fuel tank cap.



Fuel
Off

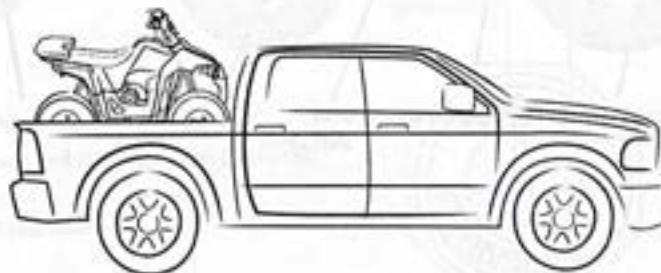

DESCRIPTION

TRANSPORTING THE ATV



LEFT SIDE

RIGHT SIDE

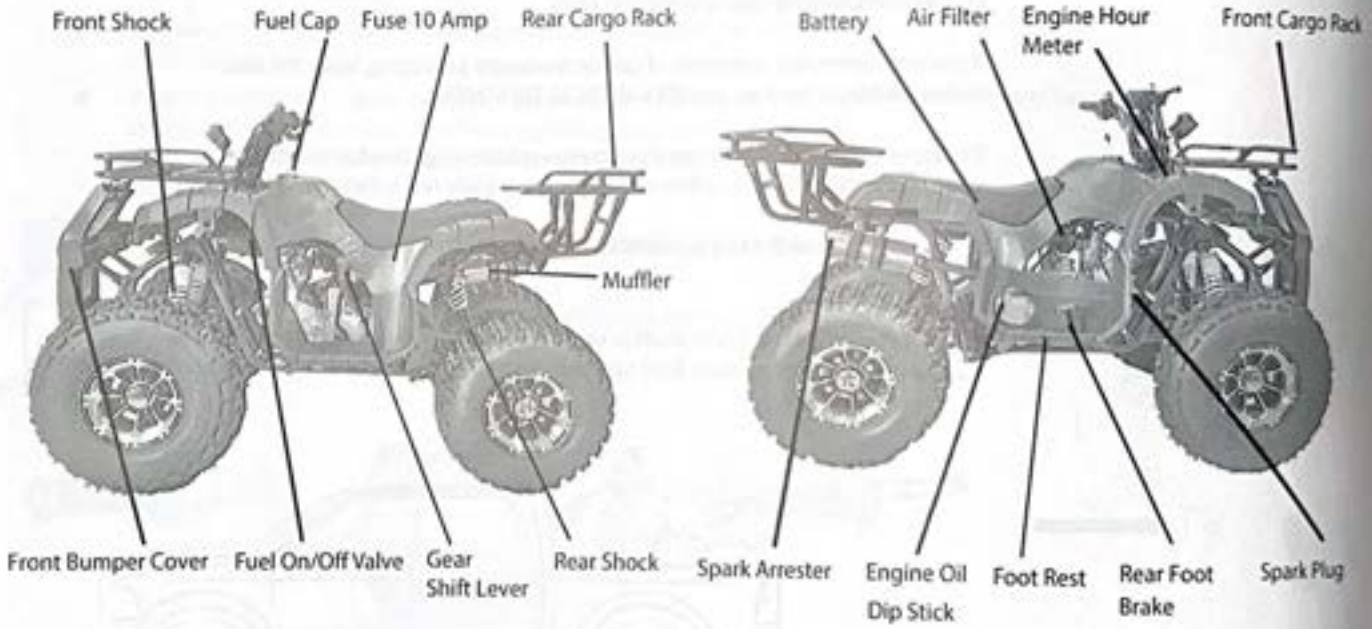

CONTROL LAYOUT

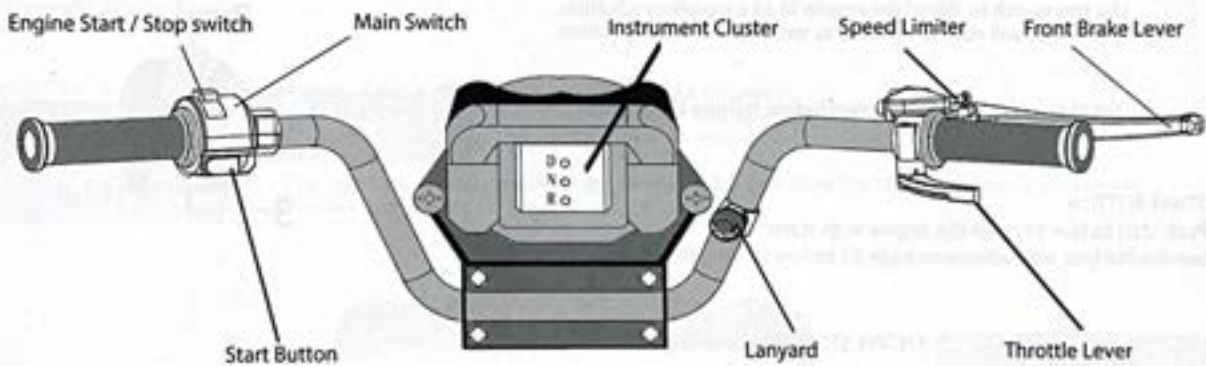

CONTROLS & FUNCTIONS

IGNITION SWITCH

The positions of the ignition switch are as follows.

Ignition ON All electrical systems are supplied with power, and the engine can be started.

The key cannot be removed.

Ignition OFF All electrical systems are off. The key can be removed.



MAIN SWITCH

Engine Start/Stop switch



Use this switch to "Stop" the engine in an emergency situation. The engine will not start when this switch is set to this position.



Set this switch to "Run" position before starting the engine.

START BUTTON

Push start button to crank the engine with starter. See the starting instructions on page 21 before starting the engine.

1. Engine Run
2. Engine Stop
3. Start Button

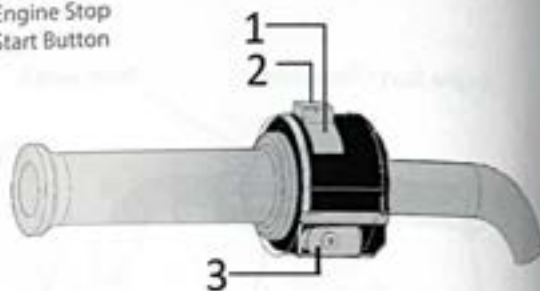

NOTICE

ENGINE STOP SWITCH WITH LANYARD

Lanyard cap must be pushed in all the way for the engine to start.

DAYTIME RUNNING LIGHT

This New TForce ATV is equipped with day time running light only . This ATV is not intended for night time riding.

WARNING

This ATV is not intended for night time riding .
The lights on this vehicle are daytime running lights only.

THROTTLE

Once the engine is running, push the throttle lever to increase the engine speed. Regulate the speed of the ATV by varying the throttle position. The throttle lever is spring-loaded to return to the start position when let go. Before starting the engine, make sure the throttle lever is smooth in operation and will return to the start position. If throttle lever is not smooth in operation or will not return to start position do not start engine.

INSTRUMENT CLUSTER

The Instrument cluster displays important information about the ATV. Make sure the rider is familiar with all the information displayed before riding ATV.

Instrument cluster icons

Gear indicator D,N,R

When "D" is displayed on the instrument panel the forward gear is engaged.

When "R" is displayed on the instrument panel the reverse gear is engaged.

When "N" is displayed on the instrument panel the neutral gear is engaged.

NOTICE

The ignition switch must be set to the "ON" position for the instrument cluster to display any icons.

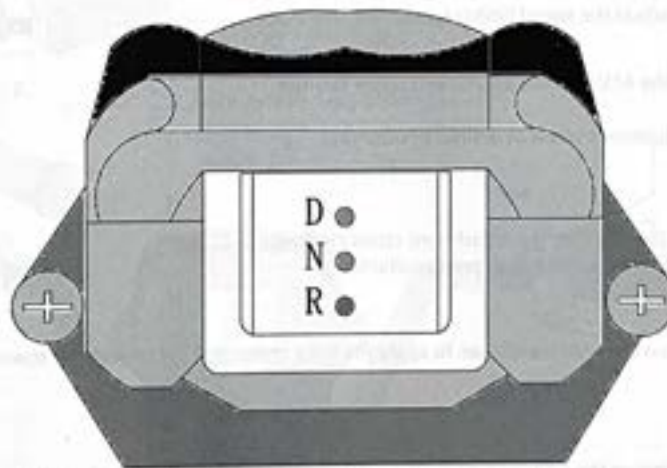



SPEED LIMITER

The New TFORCE ATV is equipped with a vehicle speed limiter adjusting screw. Beginning riders should start with slowest setting to learn how to control this vehicle. Once the operator has demonstrated mastery of the ATV, the supervising adult can adjust speed limiter screw to increase the top speed. The vehicle speed limiter keeps the throttle from fully opening, even when the throttle lever is pushed to the maximum. The adjusting screw may be gradually turned out as the beginner becomes more familiar with operating this ATV.

NOTICE

The adjustable speed limiter screw must be installed for operation. Failure to install a speed limiter screw may result in water or dirt ingestion and potential damage to the vehicle.

SPEED LIMITER ADJUSTMENT

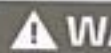

WARNING

Adults should always limit maximum restricted speed within the ability and capacity of the child to operate the ATV safely. Never allow the child to adjust the speed limiter screw.

To increase top speed

1. Loosen locknut (#1).
2. To increase the top speed of the ATV turn the adjustment screw counter clockwise. (#2).
3. Tighten the locknut to set adjustment screw in desired position(#1).

To decrease top speed

1. Loosen locknut (#1).
2. To decrease the top speed of the ATV turn the adjustment screw clockwise. (#2).
3. Tighten the locknut to set adjustment screw in desired position(#1).

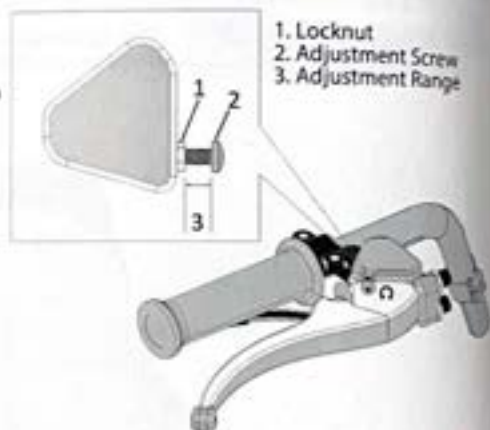

FRONT BRAKE LEVER

The front brake lever is located on the right handlebar. To apply the front brake, pull the brake lever toward the handlebar grip.

REAR FOOT BRAKE LEVER

The rear foot brake lever is located on the right foot rest. To apply the rear brake, push the brake with your right foot toward the ground.

PARKING BRAKE

Use the parking brake before starting the engine or after parking the ATV, especially on a slope. This ATV is equipped with front axle parking brake.

Front Axle Parking Brake: Apply the front brake lever and push down the lock button to apply the parking brake. Squeeze the front brake lever to release the parking brake.

⚠ WARNING

Always set the parking brake before starting the engine. The ATV could start moving unexpectedly if the parking brake is not applied. This could cause loss of control or a collision. Always be sure you have released the parking brake before you begin riding. The brakes could overheat if you ride the ATV without releasing the parking brake. You could lose control or cause an accident.

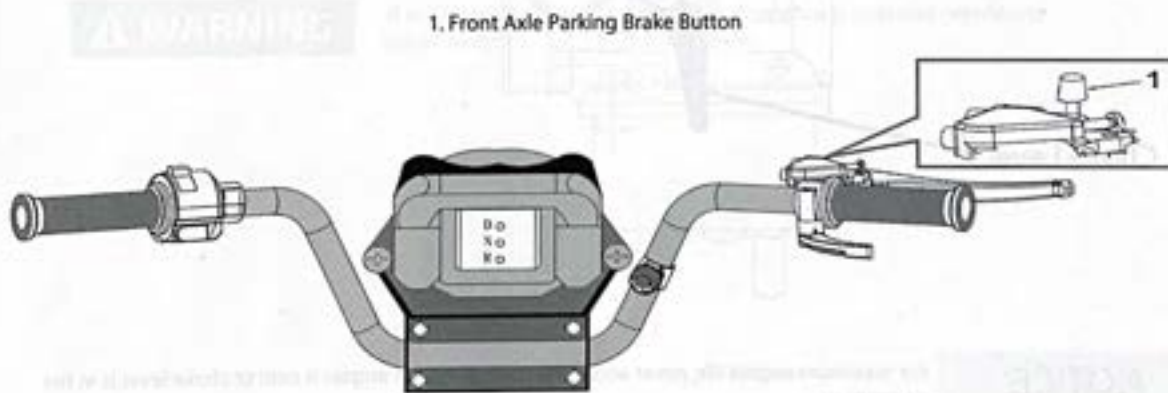

CHOKE LEVER

Starting a cold engine requires a richer air-fuel mixture. Move the choke lever all the way up when starting a cold engine. Once the engine is warmed up return the choke lever all the way down in the running position.

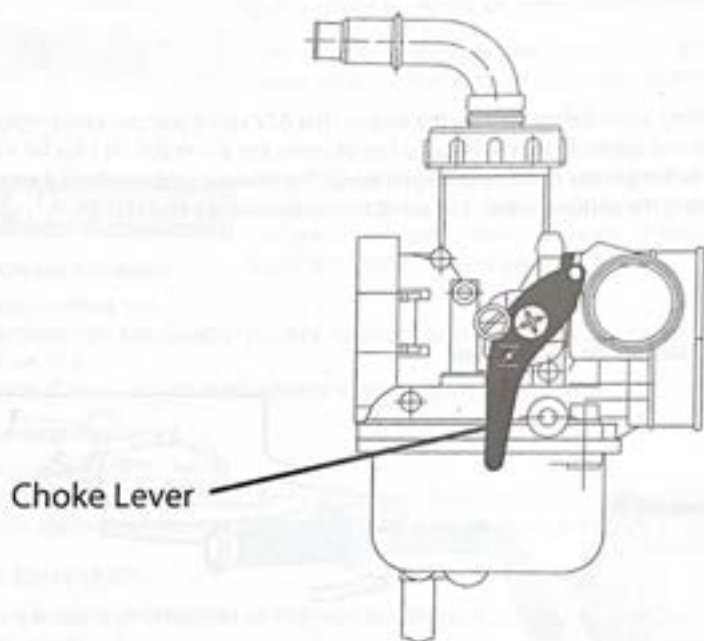

NOTICE

For maximum engine life, never accelerate hard when the engine is cold or choke lever is in the on position.

FUEL TANK CAPACITY

FUEL TANK CAP

⚠ WARNING

Gasoline and gasoline vapors are extremely flammable. To avoid fires, explosions and to reduce the risk of injury when refueling, follow these instructions.

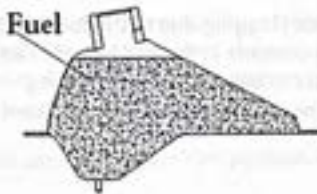

1. Before refueling, turn off the engine and be sure that no one is sitting on the vehicle. Never refuel while smoking or while in the vicinity of sparks, open flame, or other sources of ignition such as the pilot light of water heaters and clothes dryers.
2. Do not overfill the fuel tank. When refueling, be sure to insert the pump nozzle into the fuel tank filler hole. Stop filling when the fuel reaches the bottom of the filler tub. Because fuel expands when it heats up, outside heat can cause fuel to expand and overflow fuel tank.

⚠ WARNING

If any fuel spills during fueling please wipe quickly, fuel may deteriorate plastic body.

FUEL TANK CAP

WARNING

Remove the fuel tank cap by turning it counter clockwise.
Turn the fuel tank cap fully clockwise to make sure it is securely closed

Your ATV's engine has been designed to use regular unleaded gasoline with a pump octane number of 91 or higher.

Using Ethanol-added fuel may lead to carburetor clogging due to the fuel's sulfuric content reacting with brass and aluminum components in the fuel system. Tao Motor always recommends using a fuel stabilizer to help mitigate damaging corrosion. Visit your dealer to purchase recommended stabilizers and lubricants.

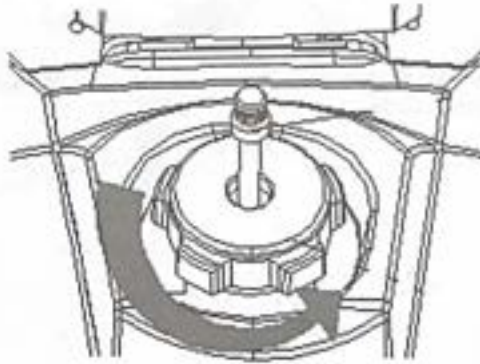

FUEL COCK/ FUEL VALVE

FUEL COCK/ FUEL VALVE

The fuel cock/valve supplies fuel from the tank to the carburetor.
The fuel cock/valve lever positions are explained as follows and shown in the illustrations.

FUEL OFF

Arrow mark positioned over "OFF" position. Fuel is off and fuel will not flow to the carburetor. Always turn the fuel valve to the "OFF" position and allow the engine to idle until it burns remaining fuel in the line when the ATV is being stored. Once the fuel in the line has been cleared, drain the carburetor bowls. Following this procedure will help reduce corrosion and carburetor damage.

FUEL ON

Arrow mark positioned over "On" position. Fuel is on and fuel will flow to the carburetor.

STORAGE

Drain gasoline from the fuel tank and carburetor of the ATV if being stored for more than over 48hrs.



Fuel Off



Fuel ON

SEAT

To Remove Seat

To remove the seat, pull the seat lock lever(#1) backward and then pull up the seat. The seat lock is located under the seat in the back of the ATV.

To Install Seat

Insert tab(#3) on the front of the seat into the seat holder(#2) and push down on the seat at the rear. Make sure that the seat is securely installed in place and will not move during operation.



1. Seat Lock Lever

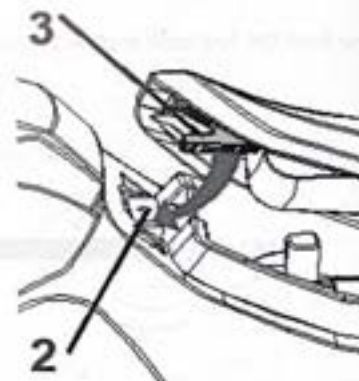

2. Frame 3. Seat Tab

BATTERY

Battery Removal

1. Make sure the ignition switch is set to the "OFF" position.
2. Remove seat
3. Disconnect the negative cable from the battery by unscrewing battery terminal bolt.
4. Disconnect the positive cable from the battery by unscrewing battery terminal bolt.
5. Remove battery from battery tray .

Battery Installation

1. Insert battery into battery tray with battery terminal nuts and bolts already installed on the battery.
2. Remove battery terminal bolts.
3. Connect positive cable and re-screw battery terminal bolt.
4. Connect negative cable and re-screw battery terminal bolt.
5. Reinstall seat.

NOTICE

Positive (+) cable is red in color.
Negative(-) Cable is in black in color.

WARNING

Battery electrolyte is poisonous and dangerous, acid contains sulfuric acid, which can cause severe burns. Avoid contact with skin, eyes or clothing. Always shield your eyes when working near batteries.

EXTERNAL: Flush with water.

INTERNAL: Call a physician immediately and get medical attention.

EYES: Rush with water for 15 minutes and get prompt medical attention.

Batteries produce explosive gases. Keep sparks, flame, cigarettes or other sources of ignition away. Ventilate when charging or using in an enclosed space.

KEEP OUT OF REACH OF CHILDREN.

Battery (5 Amp)

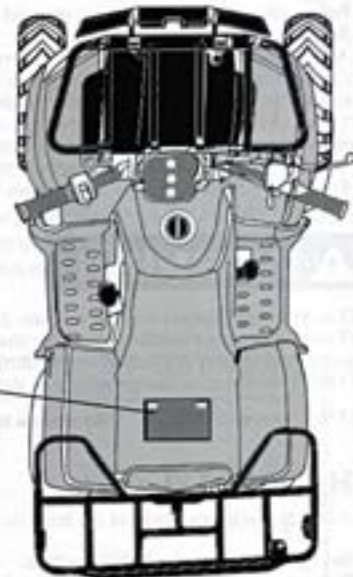

BATTERY CHARGING

1. Before charging the battery, set ignition key to the "OFF" position.
2. Remove seat.
3. Attach battery charger clamps to battery terminals.
4. Connect low-voltage battery charger to AC outlet. Use GFI AC Type outlet if possible for additional electrical safety.
5. Check charging level and if charging is complete every 4 to 8 hours to prevent dangerous overcharging of battery.
6. When charging complete unplug battery charger from wall outlet.
7. Disconnect battery charge cables from battery terminals.
8. Reinstall seat.

WARNING

DO NOT charge battery with more than 2 Amp trickle charger.
DO NOT charge the battery any longer than 8 hours.
If you notice battery is swelling or bubbling, disconnect battery charger immediately
DO NOT continue to charge battery or attempt to recharge.

DO NOT jump start this ATV by using a car battery or any other vehicles.



Main Fuse Location

CHANGING FUSE

The fuse box is located behind the body on the rear left of the ATV.

1. Set ignition key to the "OFF" position.
 2. Remove the blown fuse, check for any shorts or electrical issues and then install a new fuse of same amperage as specified. And then install a new fuse of the specified amperage.
 3. Set ignition key to the "ON" position, to check if all the devices are operating.
 4. Reinstall seat.
- If a fuse continues to blow, contact your local Tao Motor dealer to check for electrical repair.

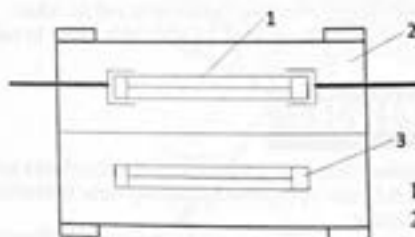

1. Main Fuse (10 Amp)
2. Fuse Holder
3. Spare Fuse

WARNING

Always use a fuse of the specified rating. Never use any substitute fuses or larger amp fuses than the original rated fuses. Any improper fuse or substitute fuse can cause electrical damage or fire and will invalidate your vehicle's warranty.

PRE-RIDE SAFETY CHECKS

Inspect the ATV prior to each use to ensure it is in a safe operating condition. Always follow the inspections, procedures and schedules described in the Owner's Manual.

WARNING

Failure to inspect or maintain the vehicle properly increases the possibility of an accident or equipment failure. Do not operate the vehicle if any problem is discovered. If a problem cannot be corrected by the procedures described in this manual, have the vehicle inspected by a Tao Motor dealer.

ITEM	ROUTINE	PAGE
Fuel (91 octane min.)	<ul style="list-style-type: none">• Check fuel level in fuel tank, and add recommended fuel if necessary.• Add Fuel Stabilizer if using ethanol fuel.• Check fuel line for leakage. Correct if necessary.	11-13
Engine Oil	<ul style="list-style-type: none">• Check oil level in engine, and add recommended oil to specified level if necessary.• Check ATV for oil leakage. Correct if necessary.	50-51
Front Brake	<ul style="list-style-type: none">• Check operation, and correct if necessary.• Lubricate cable if necessary.• Check lever free play, and adjust if necessary.	25-27
Rear Brake	<ul style="list-style-type: none">• Check operation, and correct if necessary.	27-28

ITEM	ROUTINE	PAGE
Throttle Lever	<ul style="list-style-type: none"> • Make sure that operation is smooth. Lubricate cable and lever housing if necessary. • Check lever free play, and adjust if necessary. 	25
Control Cables	<ul style="list-style-type: none"> • Make sure that operation is smooth. Lubricate if necessary. 	25-27
Drive Chain	<ul style="list-style-type: none"> • Check chain slack, and adjust if necessary. • Check chain condition. Lubricate if necessary. 	54-56
Wheels & Tires	<ul style="list-style-type: none"> • Check wheel condition, and replace if damaged. • Check tire condition and tread depth. Replace if necessary. • Check air pressure. Keep tires inflated per the PSI specified in manual. 	20
Brake Levers	<ul style="list-style-type: none"> • Make sure that operation is smooth. Lubricate lever pivoting points if necessary. 	25-27
Chassis Fasteners	<ul style="list-style-type: none"> • Make sure that all nuts, bolts and screws are properly tightened. 	20
Instruments & Switches	<ul style="list-style-type: none"> • Check operation, and correct if necessary. 	5-7

FUEL

Make sure that there is sufficient fuel in the tank. Never overfill fuel tank.

ENGINE OIL

Make sure that the engine oil is at the specified type. Follow manual's specifications, keep filled as needed, but never overfill.

AIR FILTER: The air filter has an oiled foam element. It must be inspected daily or more frequently when riding in dusty conditions. It should be cleaned and re-lubed whenever it appears dry or visible dirt is present. Refer to page 52 for instructions and recommended lubricants. A dry or dirty air filter can allow dirt to enter the engine. Engine damage due to improper air filter maintenance is not covered under warranty.

DRIVE CHAIN: The drive chain should be inspected daily. If it appears dry or has excessive slack, it must be adjusted and lubricated. Refer to the Owner's Manual for instructions and recommended lubricants.

For more information on service and maintenance go to www.taomotor.com

FRONT & REAR BRAKES

BRAKE LEVER

Check for too much free play in brake levers. If there is too much free play or if the brake levers require adjusting, have your Tao Motor dealer check the brake levers and brakes and have the brakes adjusted to the driver.

BRAKE OPERATION

Test the brakes at slow speed after starting out to make sure they are working properly. If the brakes do not provide proper braking performance, check the brake shoes/pads for wear.

THROTTLE LEVER

Check the operation of the throttle lever. It must open smoothly and spring back to the idle position when released. If throttle is not operating properly DO NOT START ENGINE. Have a Tao Motor dealer correct the issue before operating this ATV.

SWITCHES

Check to ensure all switches are working properly before starting the engine.

DRIVE CHAIN

Check the condition of the drive chain and check the drive chain slack. Lubricate and adjust the drive chain as necessary.

TIRES

Check tire pressure with tire gauge to make sure that both front tires and rear tires are equally inflated and meet the recommended PSI specifications. All Tao Motor ATVs are installed with tubeless, low-pressure ATV valved tires.



TIRE WEAR LIMIT

When the tire groove decreases to 3mm (0.12 in) due to wear, replace the tire. Never operate an ATV with worn tires, as this may cause loss of control, increasing your risk of an accident or death.



CHASSIS FASTENERS

Make sure that all nuts, bolts and screws are properly tightened before starting engine.

STARTING ENGINE (COLD)

1. Set the parking brake. (The engine can be started only when the front / rear brake lever is applied.)
2. Turn the fuel valve lever to the "ON" position.
3. Turn the ignition key to the "ON" position.
4. Set "RUN" position on main switch.
5. Set gear box to neutral position. The neutral position light will illuminate on instrument cluster.
6. Set the choke lever to cold start position (all the way up).
7. Press and hold the start button until the engine starts. Never hold the start button for more than 10 seconds per try. It may be necessary to push the throttle lever a small amount to start the engine.
8. When engine warms up, move the choke lever down. Choke lever must be in the off position (all the way to the down) in order to operate the ATV.
9. Release the parking brake.

STARTING ENGINE (WARM)

1. Set the parking brake. (The engine can be started only when the front / rear brake lever is applied).
2. Turn the fuel valve lever to the "ON" position.
3. Turn the ignition key to the "ON" position.
4. Set "RUN" position on main switch.
5. Set gear box to neutral position. The neutral position light will illuminate on instrument cluster.
6. Set the choke lever to warm start position (all the way to down).
7. Press and hold the start button until the engine starts. Never hold the start button more than 10 seconds per try. It may be necessary to push the throttle lever a small amount to start the engine.
8. Release the parking brake.

ENGINE BREAK-IN

Proper engine break-in will increase the lifespan of your Tao Motor vehicle ATV. The engine break-in period is the initial 20 hours of operation. You should avoid maintaining a constant engine RPM and do not operate your ATV above 1/2 throttle during the break-in period. Do not operate your ATV at full throttle during the break-in period.

NOTICE

First service, including the break-in service work should be performed at 10 hours. The second service should be performed at the end of the 20-hour break-in period. Subsequent service work should be performed after every 20 hours of operation.

HOT MUFFLER & ENGINE

The muffler and other engine parts become extremely hot during operation and remain hot after the engine has stopped. To reduce the risk of fire during operation or after leaving the ATV, do not let brush, grass and other materials collect under the vehicle, near the muffler or exhaust pipe, or next to other hot parts. Check under the vehicle after operating in areas where combustible materials may have collected. Do not run the vehicle in idle of after running by parking in long dry grass or other dry combustible organic materials.

To prevent burns, avoid touching the exhaust system. Park the ATV in a place where pedestrians or children are not likely to touch it.

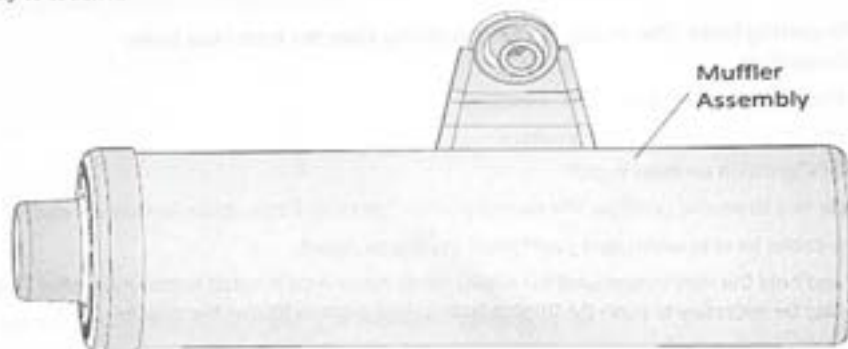

PARKING

When parking the ATV: first apply the brake lever, stop the engine, apply the parking brake, and then turn the fuel valve to "OFF" position. Never park the ATV on hills that are too steep to walk up easily.

ACCESSORIES & MODIFICATIONS

Any modifications made to your vehicle's design or operation can put you and others at great risk of serious injury or death. Never install accessories that would impair the performance/function of your ATV. Carefully inspect the accessory before using it to make sure that it does not in any way reduce ground clearance, limit suspension travel, steering travel or control operation.

Use caution when adding any electrical accessories or change the normal operation of the vehicle. If electrical accessories exceed the capacity of the ATV's electrical system, could results in a dangerous situation and possible loss of power or damage the engine.

Installing aftermarket parts and/or accessories could void your Tao Motor factory warranty. See a Tao Motor dealer for more details.

REAR CARGO RACK

Rear cargo rack can carry a maximum of 11 lbs, and should never be overloaded. Use caution when loading the cargo rack and make sure cargo is secured with tie downs to prevent load shift.

NOTICE

Overloading your New TFORCE could cause a lack of control resulting in severe injury or death.

GEAR SELECTOR LEVER

This ATV is equipped with a 2 gear transmission gearbox.

The gear shift lever is located on the left side of the ATV. When changing the transmission position, first apply the brakes to come to a complete stop, before moving the lever to the desired position.

To Engage Forward Gear: Push forward on gear shifter lever, once the gear engages, release the shifter lever and it will return the center position.

To Engage Reverse Gear: Pull back on gear shifter lever until the shifter engages, then release the shifter and allow the shifter to return to the center position.

When "D" is displayed on the instrument panel the forward gear is engaged.

When "R" is displayed on the instrument panel the reverse gear is engaged.

When "N" is displayed on the instrument panel the neutral gear is engaged.

▲ WARNING

Always look behind the vehicle prior to shifting in reverse to be clear of any obstacles, animals or people. Remain seated all times, do not stand up.

NOTICE

Always completely stop the ATV and apply the brakes prior to moving the transmission lever.

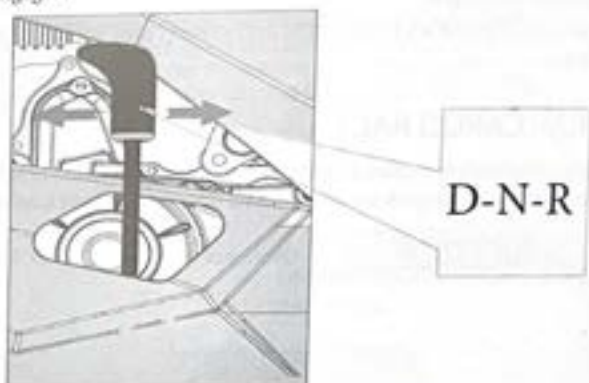

Care should be used when riding on loose or slippery surfaces since the ATV may slide. Unexpected or uncorrected sliding can lead to an accident. You reduce the tendency of front wheel sliding by positioning your body weight forward towards the front of the vehicle while remaining seated.

If your rear wheels start to slide in a sideway motion, you may be able to regain control by steering in the opposite direction. Applying the brakes quickly or accelerating when sliding out of control is not recommended until you have corrected the slide.

THROTTLE CABLE

Throttle cable inspection

Inspect throttle cable for excessive wear, kinking or fraying. Ensure cable moves freely.

NOTE

The throttle cable must be replaced if any signs of wear, fraying or other damages found.

THROTTLE CABLE ADJUSTMENT

Check throttle lever free-play, adjust if necessary.

NOTE

Please check with Tao Motor dealer if throttle cable adjustment can not be adjusted properly.

Normal throttle free-play is 5mm to 10mm 0.197 In to 0.394

TIP

Lubricate cable using silicone cable lubricant to reduce premature wear and to ensure proper movement of the cable.

To adjust throttle cable,

1. Pull rubber dust covers back to inspect and adjust throttle cable.
2. Loosen lock nut.
3. Turn throttle cable adjuster to make proper adjustments of throttle cable.
4. Tighten locking nut and reinstall rubber dust cable covers.

NOTE

Measure throttle free play at the tip of the lever.

Check proper throttle cable adjustment by turning handlebars completely to the left and right. If RPM increases when turning, then re-adjust throttle cable to increase lever free-play. Check throttle cable routing to make sure there is no cable binding when turning handlebars.

NOTE

The handlebar should move left to right without change in engine RPM.

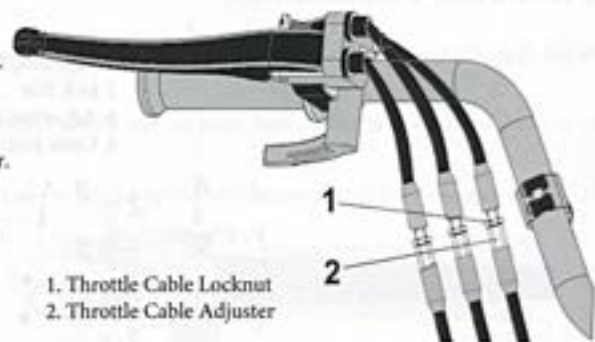

1. Throttle Cable Locknut
2. Throttle Cable Adjuster

FRONT BRAKE LEVER

Recommended brake service by certified Tao Motor technician. See your Tao Motor Dealer for details.



WARNING

Operating with improperly adjusted brakes could lead to a loss in braking ability and or cause an accident. Brakes can become very hot during prolonged braking or use. Never touch brakes until they are cool.

How to adjust front brake lever free-play.

The front brake lever freeplay must be checked and if necessary adjusted at the intervals specified in the periodic maintenance and lubrication chart. The brake lever freeplay should measure 9.3-13.3 mm (0.37-0.52 in) as shown.

How to adjust brake lever freeplay upper

1. Loosen the locknut's (#2)
2. Adjusting bolt's (#1).
3. Adjusting bolt's (#1) in direction (a) to increase the lever freeplay, and in direction (b) to decrease it.
4. Tighten the locknut's(#2).
5. While applying the front brake the upper and lower cable lengths should be equal .
6. The cable joint(#4) will become vertical.

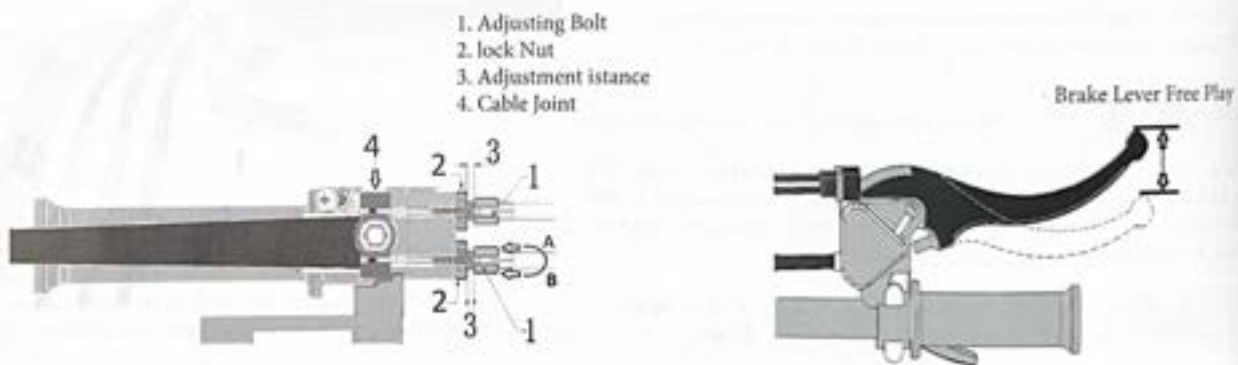

FRONT BRAKE LEVER FREEPLAY LOWER ADJUSTMENT

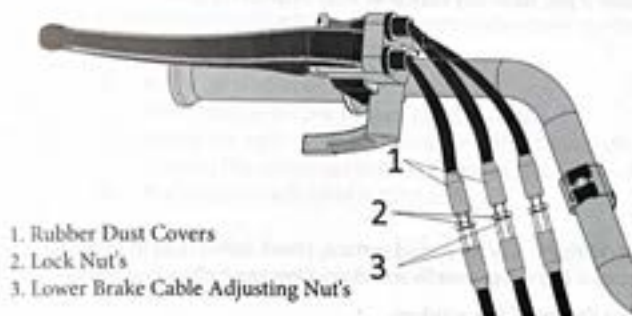

1. Rubber Dust Covers
2. Lock Nut's
3. Lower Brake Cable Adjusting Nut's

If the upper brake cable adjuster is threaded out to it's near limits, or the correct freeplay cannot be obtained, attempt to adjustment with the lower cable adjustment.

1. Pull back the rubber dust covers.
 2. loosen the lock nut's.
 3. Turn the lower adjusting nut's and check lever free play.
 4. Tighten lock nut's.
 5. Install rubber dust cover.
- Make sure both brake cables are adjusted evenly.

HYDRAULIC REAR BRAKE

⚠ WARNING

New brakes will not perform to their maximum efficiency until after their initial brake-in is complete. Use extra caution.

⚠ WARNING

Brake fluid replacement or brake system maintenance and repairs should be performed by an authorized Tao Motor dealer.

NOTICE

The brakes can be very hot after prolong use of the vehicle and can cause burns. Wait for the brakes to cool down.

The rear brake system is a hydraulic type and no adjustment is required. Use the following checklist before each use to maintain the brake system in good operation condition;

- Brake Fluid level
- Brake system for fluid leaks
- Brake cleanliness
- Brake disk for excessive wear and surface condition.
- Brake pads for wear, damage or looseness.

NOTICE

Have your local Tao Motor dealer inspect brakes system for wear or damage.
Always contact your local Tao Motor Dealer if you have any concerns after inspecting your brake system for wear or damage.

Recommended Brake Fluid

Always use brake fluid type DOT 3 or 4.

Brake Fluid Level

Always check for the proper brake fluid reservoir level as follows:

Brake fluid reservoir is located on the frame in front of the right rear tire. With the ATV on a level surface, check brake fluid in reservoir for proper level. The fluid should be above the MIN mark. Add fluid as required, but never overfill and clean filler cap before removing.

NOTICE

The Reservoir is full when the fluid reaches the top of the window.
A low fluid level may indicate leaks or worn brake pads.

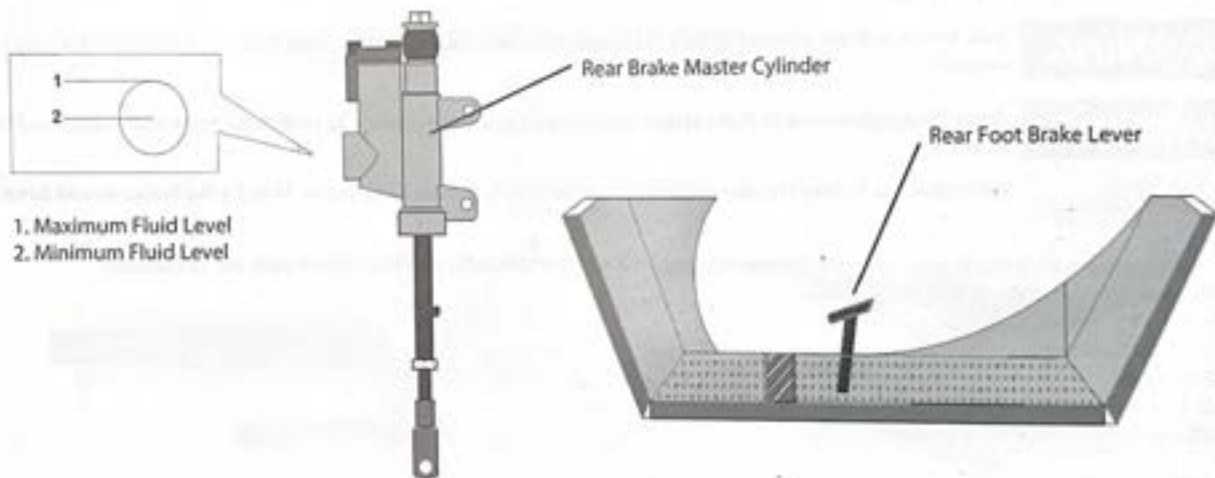

ENGINE IDLE ADJUSTMENT

If it is necessary to adjust the carburetor idle screw due to changed outside environmental conditions, to adjust carburetor idle screw as follows;

1. Apply parking brake.
2. Warm up the engine by running the vehicle.
3. Adjust the carburetor idle screw until the desired idle RPM is reached. Turning the idle screw in (clockwise) to raise RPM. Turning the screw out (counterclockwise) will lower RPM.
4. The standard idle RPM is 1500 ± 150 .

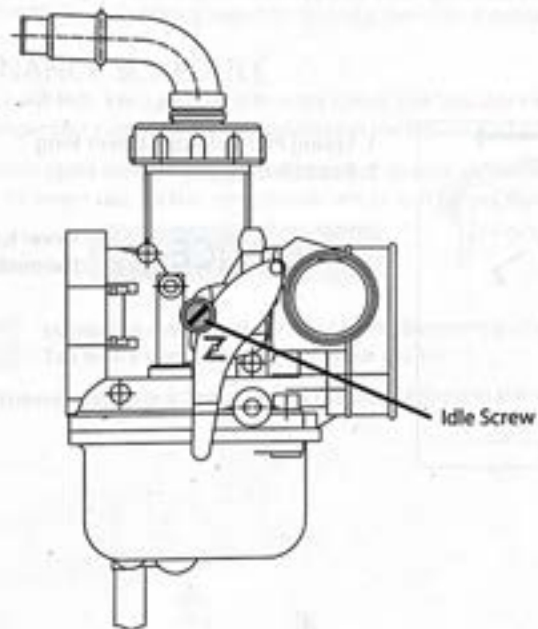

ADJUSTING SUSPENSION SPRING PRELOAD

This ATV is equipped with adjustable coil springs front and rear. The spring preload can be adjusted to suit the rider's weight and the riding conditions. Turn the spring preload adjusting ring to increase (stiffest= 5) or decrease (softest= 1) the spring preload. Increased spring tension will stiffen the ride. Decreasing spring tension will soften the ride.

NOTICE

The suspension was pre-set at the factory, but can be adjusted with a special suspension adjustment tool available for purchase at your Tao Motor dealer.

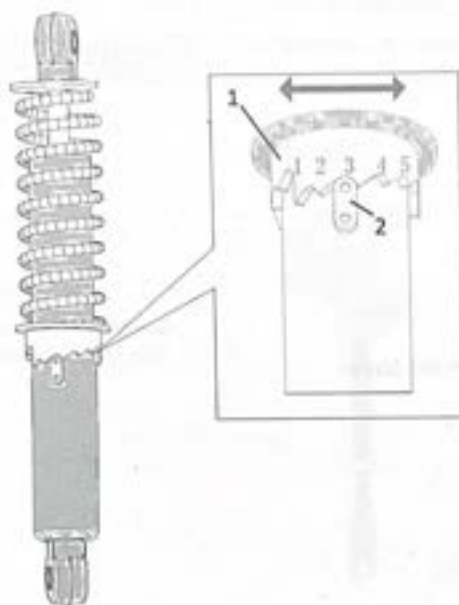

1. Spring Preload Adjustment Ring
2. Position Indicator

NOTICE

Never turn the adjusting mechanism beyond the minimum and maximum setting.

MAINTENANCE

CAUTION

Due to the nature of the adjustments marked with a \checkmark on the following chart, it is recommended that service be performed by an authorized Tao Motor dealer.

- Perform maintenance more often if you use your ATV under severe conditions, such as dirty or wet conditions to purge water or dirt contamination from grease fittings and other critical components.

PERIODIC MAINTENANCE SCHEDULE

Careful periodic maintenance will help keep your vehicle in the safest, most reliable condition. Inspection, adjustment and lubrication intervals of important components are explained in the following chart on the following pages.

Maintenance intervals are based upon average riding conditions and an average vehicle speed of approximately 10 miles per hour. Vehicles subjected to severe use, such as operation in wet or dusty areas, should be inspected and serviced more frequently.

Inspect, clean, lubricate, adjust or replace parts as necessary.

NOTE

Inspection may reveal the need for replacement parts. Always use genuine Tao Motor parts available from your dealer.

Maintaining your vehicle to the maintenance schedule in this manual is critical to the vehicle's operation.

GETTING TO KNOW YOUR ATV

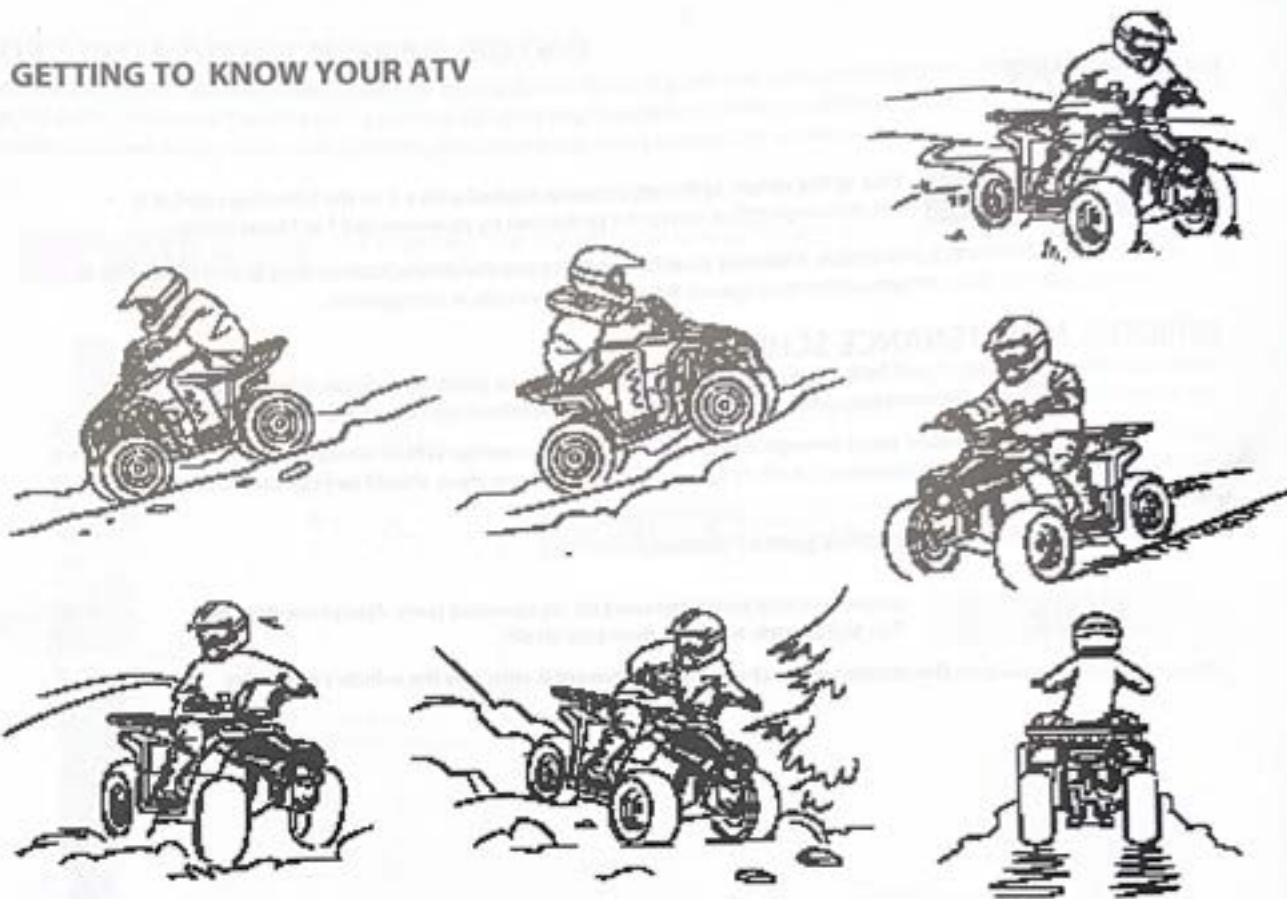

⚠ WARNING

This ATV is intended for use by operators 12 years of age and older. Adult supervision is required while a child operates any ATV.

- Do not operate this ATV or allow anyone else to operate it without proper instruction. The risk of an accident is greatly increased if the operator does not know how to operate the ATV properly in different situations and on different types of terrain.
- Do not operate this ATV at speeds too fast for your skills or the conditions, as this increases your chances of losing control of the ATV and an accident. Always go at a speed that is proper for the terrain, visibility and operating conditions, and your experience.
- This ATV is intended for recreational use by operators 12 years old and older, under adult supervision. This section, "Getting to know your ATV," provides general riding instructions which are appropriate for most types of riding. Riding your ATV requires special skills acquired through practice over a period of time. Take the time to learn the basic techniques well before attempting more difficult maneuvers. It is essential to familiarize yourself with the operation of the ATV to achieve the skill necessary to enjoy riding safely. Before you begin to ride, be sure you have read this manual completely and understand how to operate all of the ATV's controls. Pay particular attention to the safety information and all notice and warning labels on the vehicle.

TIP

Riding your ATV requires skills acquired through practice over a period of time. Become familiar with riding this ATV by riding at slow speeds first, even if you have experience riding other ATVs. Do not attempt to operate it at higher performance levels until you are familiar with this ATV's handling and performance characteristics. Take the time to learn the basic techniques well before attempting more difficult maneuvers.

TIP

If your child is a beginner or is inexperienced, he or she should take a training course, free of charge. The free training course is available to purchasers of new New TFORCES by calling 855-717-8618.

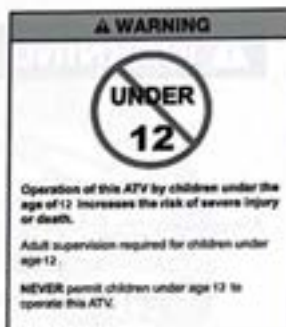

⚠ WARNING

Never carry a passenger. Carrying a passenger on this ATV greatly reduces your ability to balance and control this ATV. You could have an accident, resulting in severe injury or death to you and/or your passenger. The long seat is to allow the operator to shift position as needed during operation. It is not for carrying passengers.

SAFETY RIDING GEAR

Always wear the following to reduce risk of injury in an accident:

- Approved motorcycle helmet that fits properly
- Eye protection (goggles, helmet face shield, or protective eye wear)
- Over-the-ankle boots, gloves, long-sleeved shirt or jacket, and long pants
- An approved helmet and other personal protective equipment can reduce the severity of injuries in an accident.

⚠ WARNING

Operating without an approved motorcycle helmet increases your chances of a severe head injury or death in the event of an accident. Wear eye protection when operating your ATV to reduce the risk of a serious accident or injury. Eye protection, such as a face shield or goggles, may reduce the risk of foreign material getting in your eyes and help prevent loss of vision.

⚠ WARNING

Operating without eye protection can result in an accident and increases your chances of a severe injury in the event of an accident.



1. Protective clothing
2. Protective Goggles
3. Protective Gloves
4. Protective Boots
5. Protective Helmet



Do not operate after or while consuming alcohol or drugs.

The operator's performance capability is reduced by the influence of alcohol or drugs.

Consuming alcohol or drugs could seriously affect your judgment, cause you to react more slowly, and affect your balance and perception.

⚠ WARNING

Never consume alcohol or drugs before or while driving this ATV. You increase your chance of an accident.

DURING RIDING

Always keep your feet on the foot boards during operation; otherwise, they may contact the rear wheels.

⚠ WARNING

Removing even one hand or foot can reduce your ability to control the ATV or could cause you to lose your balance and fall off of the ATV. If you remove a foot from a foot board, your foot or leg may come into contact with the rear wheels, which could injure you or cause an accident.

Avoid wheelies and jumping.

⚠ WARNING

Attempting wheelies, jumps, and other stunts increases the chance of an accident, including an overturn. Never attempt stunts, such as wheelies or jumps. Don't try to show off.

BE CAREFUL WHERE YOU RIDE

This ATV is designed for off-road use only.

⚠ WARNING

Paved surfaces may seriously affect handling and control of the ATV, and may cause the ATV to go out of control. Always avoid paved surfaces, including sidewalks, driveways, parking lots and streets.



Do not ride on any public road, street, or highway. Riding on public roads can result in collisions with other vehicles. It is illegal to operate ATVs on public streets, roads and highways in many states.

⚠ WARNING

Never operate this ATV on any public street, road or highway, even a dirt or gravel one. You could collide with another vehicle. Know the terrain where you ride. Ride cautiously in unfamiliar areas. Stay alert for holes, rocks, or roots in the terrain, and other hidden hazards which may cause the ATV to upset.

⚠ WARNING

The ATV could go out of control if you do not have enough time to react to hidden rocks, bumps, or holes. Go slowly and be extra careful when operating on unfamiliar terrain. Always be alert to changing terrain conditions when operating the ATV.



⚠ WARNING

Do not operate on rough, slippery, or loose terrain until you have learned and practiced the skills necessary to control the ATV on such terrain. Always be especially cautious on these kinds of terrain.

Failure to use extra care when operating on excessively rough, slippery, or loose terrain could cause loss of traction or ATV control, which could result in an accident, including an overturn.

When riding in an area where you might not easily be seen, such as desert terrain, mount a caution flag on thea ATV. DO NOT use the flag pole bracket as a trailer hitch.

⚠ WARNING

You could collide with another vehicle if operating in off-road areas where you cannot easily be seen. Mount a caution flag on the ATV to make you more visible. Watch carefully for other vehicles. Do not ride in areas posted "no trespassing." Do not ride on private property without getting permission.

OPERATING YOUR New TFORCE ATV:

Select a large, flat off-road area to become familiar with your ATV. Make sure that this area is free of obstacles and other riders. You should practice control of the throttle, brakes, and turning techniques in this area before trying more difficult terrain.

Set the parking brake and follow the instruction on page 9 & 21 to start the engine. Once it has warmed up you are ready to begin riding your ATV. Remember that the engine and exhaust pipe will be hot when riding and afterwards; do not allow skin or clothing to come in contact with these components.

ACCELERATING YOUR ATV:

With the engine idling, release the parking brake. Apply the throttle slowly and smoothly. You will start to accelerate. If the throttle is applied too abruptly, the vehicle may lurch forward or the front wheels may lift off the ground, resulting in a loss of directional control. Avoid higher speeds until you are thoroughly familiar with the operation of your ATV.

When slowing down or stopping, release the throttle and apply the brakes smoothly and evenly. Improper use of the brakes can cause the tires to lose traction, reducing control and increasing the possibility of an accident.



STEERING YOUR ATV

To achieve maximum traction while riding off road, the two rear wheels turn together at the same speed. Therefore, unless the wheel on the inside of the turn is allowed to slip or lose some traction, the ATV will resist turning. A special turning technique must be used to allow the ATV to make turns quickly and easily. It is essential that this skill be learned first at low speed.

As you approach a curve, slow down and begin to turn the handlebars in the desired direction. As you do so, put your weight on the foot board to the outside of the turn (opposite your desired direction) and lean your upper body into the turn. Use the throttle to maintain an even speed through the turn. This maneuver will let the wheel on the inside of the turn slip slightly, allowing the ATV to make the turn properly.

This procedure should be practiced at slow speed many times in a large off-road area with no obstacles. If an incorrect technique is used, your ATV may continue to go straight. If the ATV doesn't turn, come to a stop and then practice the procedure again. If the riding surface is slippery or loose, it may help to position more of your weight over the front wheels by moving forward on the seat.

Once you have learned this technique, you should be able to perform it at higher speeds or in tighter curves.

Improper riding procedures such as abrupt throttle changes, excessive braking, incorrect body movements, or too much speed for the sharpness of the turn may cause the ATV to tip. If the ATV begins to tip over to the outside while negotiating a turn, lean more to the inside. It may also be necessary to gradually let off on the throttle and steer to the outside of the turn to avoid tipping over.



⚠ WARNING

Avoid higher speeds until you are thoroughly familiar with the operation of your ATV. Do not attempt to climb hills until you have mastered basic maneuvers on flat ground. Always check the terrain carefully before attempting any hill. In all cases avoid inclines with slippery or loose surfaces, or obstacles that might cause you to lose control.

UPHILL RIDING

To climb a hill, you need traction, momentum and steady throttle. Travel fast enough to maintain momentum, but not so fast that you cannot react to changes in the terrain as you climb.

⚠ WARNING

It is important when climbing a hill to make sure that your weight is transferred forward on the ATV. This can be accomplished by leaning forward and, on steeper inclines, standing on the foot boards and leaning forward over the handlebars. Whenever possible, ride straight up hills. Slow down when you reach the crest of the hill if you cannot see clearly what is on the other side - there could be another person, an obstacle, or a sharp drop-off. Use common sense and remember that some hills are too steep for you to climb or descend.



If you are climbing a hill and you find that you have not properly judged your ability to make it to the top, you should turn the ATV around while you still have forward motion (provided you have the room to do so) and go down the hill. If your ATV has stalled or stopped and you believe you can continue up the hill, restart carefully to make sure you do not lift the front wheels which could cause you to lose control. If you are unable to continue up the hill, dismount the ATV on the uphill side. Physically turn the ATV around and then descend the hill.



If you start to roll backwards, DO NOT apply the brakes abruptly. Apply only the front brake. When fully stopped, apply the rear brake as well, and then lock the parking brake. The ATV could easily tip over backwards so immediately dismount the ATV on the uphill side or to the left-hand side when the ATV is pointed straight uphill. If possible, get help to turn the ATV around and then remount it when safe and ride downhill carefully as explained in the next section.

⚠ WARNING

Stalling, rolling backwards or improperly dismounting while climbing a hill could result in ATV overturning. If you cannot control the ATV, dismount immediately on the uphill side.

DOWNHILL RIDING

When riding your ATV downhill, shift your weight as far to the rear and uphill side of the ATV as possible. Move back on the seat and sit with your arms straight. Engine compression will do most of the braking for you.

Use caution while descending a hill with loose or slippery surfaces. Braking ability and traction may be adversely affected by these surfaces. Improper braking may also cause a loss of traction. Gradually apply only the rear brake.

Whenever possible, ride your ATV straight downhill. Avoid sharp angles which could allow the ATV to tip or roll over. Carefully choose your path and ride no faster than you will be able to react to obstacles which may appear.



RIDING SLOPING SURFACE

Traversing a sloping surface on your ATV requires you to properly position your weight to maintain proper balance. Be sure that you have learned the basic riding skills on flat ground before attempting to cross a sloping surface. Avoid slopes with slippery surfaces or rough terrain that may upset your balance.

As you travel across a slope, lean your body in the uphill direction. It may be necessary to correct the steering when riding on loose surfaces by pointing the front wheels slightly uphill. When riding on slopes, be sure not to make sharp turns either up or down hill. If your ATV does begin to tip over, gradually steer in the downhill direction if there are no obstacles in your path. As you regain proper balance, gradually steer again in the direction you wish to travel.

WATER CROSSINGS

The ATV can be used to cross slow moving, shallow water of up to a maximum of 11 cm (3 in) in depth. Before entering the water, choose your path carefully. Enter where there is no sharp drop off, and avoid rocks or other obstacles which may be slippery or upset the ATV. Drive slowly and carefully.

Test your brakes after leaving the water. If necessary, apply them several times to let friction dry out the linings. Do not continue to ride your ATV without verifying that you have regained proper braking ability.

WARNING

Wet brakes may have reduced stopping ability, which could cause loss of control. After riding your ATV in water, be sure to drain any potentially trapped water by removing the air filter case.

RIDING OVER ROUGH TERRAIN

Riding improperly over obstacles could cause loss of control or a collision. Before operating in a new area, check for obstacles. Never attempt to ride over large obstacles, such as large rocks or fallen trees. When you go over obstacles, always follow proper procedures as described in the Owner's Manual. Riding over rough terrain should be done with caution. Look out for obstacles which could cause damage to the ATV or could lead to an accident. Be sure to keep your feet firmly mounted on the foot boards at all times. Avoid jumping the ATV and always ride within your abilities.

SLIDING AND SKIDDING

Skidding or sliding improperly may cause you to lose control of this ATV. You may also regain traction unexpectedly, which may cause the ATV to overturn. Learn to safely control skidding or sliding by practicing at low speeds and on level, smooth terrain. On extremely slippery surfaces, such as ice, go slowly and be very cautious in order to reduce the chance of skidding or sliding out of control.

SPECIFICATION CHART

Fuel Tank	0.92 Gal (3.5L)
Engine Oil	SAE 15W40
Climbing	≥12°
Acceleration Noise Level	≤80dB
Recommended Tire Pressure	5 PSI

CHASSIS

Brake Front/Rear	Front Drums, Rear Disc Brake
Brake	Hand Brake, Foot Brake
Front Tire	19x7-8
Rear Tire	18x9.5-8
Max Front Tire Pressure	10 PSI, max
Max Rear Tire Pressure	10 PSI, max
Minimum Front Tire Pressure	2.0 PSI, max
Minimum Rear Tire Pressure	2.0 PSI, max
Weight GW	260lbs

DIMENSIONS

Overall Length	68.9 in. (1,750mm)
Overall Width	41.1 in. (1,045mm)
Overall Height	38.1 in (970mm)
Seat Height	25.9 in. (660mm)

ENGINE

Type	Single-Cylinder Four-Stroke, Air-Cooled, Automatic Centrifugal Clutch
Displacement	120CC
Bore X Stroke	52.4 mm x 55.5 mm
Idle Speed	1500±150 RPM
Start Mode	Electric start
Ignition Method	CDI
Spark Plug Gap	0.06~0.085mm
Transfer Method	Chain Drive
Compression Ratio	9.5:1
Valve Clearance	I-0.03~ E-0.05mm
Spark Plug	NST/ A7RTC NGK / CR6HSA

ENGINE HOUR METER

This ATV is equipped with an engine hour meter, this meter will display total engine running time. Hour glass symbol appears and flashes on/off to indicate counting engine run time. Total engine run time can be very useful to maintain your ATV. See general maintenance chart for more information.



NOTICE

Engine hour meter has an internal battery, the display will stay on even when the ATV's battery is disconnected.

PERIODIC MAINTENANCE CHART FOR THE EMISSION CONTROL SYSTEM

- For ATVs not equipped with an odometer follow the month maintenance intervals.
- For ATVs equipped with an odometer or an hour meter, follow the km (mi) or hours maintenance intervals. However, keep in mind that if the ATV isn't used for a long period of time, the month maintenance intervals should be followed.
- Items marked with an asterisk should be performed by a dealer as they require special tools, data and technical skills.
- Off-road vehicles require regular maintenance. The following items are critical to keep your Tao Motor ATV performing correctly.

No.	ITEM	CHECK OR MAINTENANCE JOB	WHICHEVER COMES FIRST		INITIAL EVERY			
			Month	1	3	6	6	12
			km (mi)	320 (200)	1300 (800)	2500 (1600)	2500 (1600)	5000 (3200)
			Hours	20	80	160	160	320
1	Fuel Filter*	• Check or replace if necessary.			✓	✓	✓	✓
2	Fuel Line*	• Check fuel hoses for cracks or other damage, and replace if necessary.				✓	✓	✓
3	Spark Plug	• Check condition and clean, regap, or replace if necessary.		✓	✓	✓	✓	✓
4	Valves*	• Check valve clearance and adjust if necessary.		✓		✓	✓	✓
5	Crankcase Breather System*	• Check breather hose for cracks or other damage and replace if necessary.				✓	✓	✓
6	Exhaust System*	• Check for leakage and replace gasket(s) if necessary. • Check for looseness and tighten all clamps and joints if necessary.				✓	✓	✓
7	Spark Arrester	• Clean				✓	✓	✓

GENERAL MAINTENANCE AND LUBRICATION CHART

No.	ITEM	CHECK OR MAINTENANCE JOB	WHICHEVER COMES FIRST		INITIAL EVERY				
			Month	1	3	6	6	12	
			km (mi)	320 (200)	1300 (800)	2500 (1600)	2500 (1600)	5000 (3200)	
			Hours	20	80	160	160	320	
1	Air Filter Element	• Clean and replace if necessary.	Every 20-40 hours (more often in wet or dusty areas)						
2	Front Brake*	• Check operation and correct if necessary. • Replace brake pads.	✓	✓	✓	✓	✓	✓	✓
			Whenever worn to the limit						
3	Rear Brake*	• Check operation and correct if necessary. • Check brake pedal free play and adjust if necessary. • Check fluid and ATV for fluid leaks, age, and correct if necessary. • Replace brake pads.	✓	✓	✓	✓	✓	✓	✓
			Whenever worn to the limit						
4	Brake Hoses*	• Check for cracks or other damage, and replace if necessary. • Replace.		✓	✓	✓	✓	✓	✓
			Every 2 years						
5	Rear Brake Hose Protectors*	• Check for wear, cracks or other damage, and replace if necessary.	✓	✓	✓	✓	✓	✓	✓
6	Wheels*	• Check runout for damage. Replace if necessary.	✓	✓	✓	✓	✓	✓	✓
7	Tires*	• Check tread for depth and for damage, and replace if necessary. • Check air pressure and balance, and correct if necessary.	✓	✓	✓	✓	✓	✓	✓

GENERAL MAINTENANCE AND LUBRICATION CHART CONTINUED

No.	ITEM	CHECK OR MAINTENANCE JOB	WHICHEVER COMES FIRST		INITIAL EVERY			
			Month	1	3	6	6	12
			km (mi)	320 (200)	1300 (800)	2500 (1600)	2500 (1600)	5000 (3200)
			Hours	20	80	160	160	320
8	Wheel Hub Bearings*	• Check for looseness or damage, and replace if necessary.	✓	✓	✓	✓	✓	
9	Chassis Fasteners*	• Make sure that all nuts, bolts, and screws are properly tightened.	✓	✓	✓	✓	✓	
10	Shock Absorber Assemblies*	• Check operation and correct if necessary. • Check for oil leakage and replace if necessary.			✓	✓	✓	
11	Stabilizer Bushings*	• Check for cracks or other damage, and replace if necessary.			✓	✓	✓	
12	Rear Knuckle Pivots*	• Lubricate with lithium-soap-based grease.			✓	✓	✓	
13	Steering Shaft*	• Lubricate with lithium-soap-based grease.			✓	✓	✓	
14	Steering System*	• Check operation and repair or replace if damaged. • Check toe-in and adjust if necessary.	✓	✓	✓	✓	✓	
15	Engine Mount*	• Check for cracks or other damage, and replace if necessary.			✓	✓	✓	
16	Engine Oil	• Change. • Check ATV for oil leakage, and correct if necessary.	✓	CHANGE OIL EVERY 20 HRS				

GENERAL MAINTENANCE AND LUBRICATION CHART CONTINUED

No.	ITEM	CHECK OR MAINTENANCE JOB	WHICHEVER COMES FIRST		INITIAL EVERY				
			Month	1	3	6	6	12	
			km (mi)	320 (200)	1300 (800)	2500 (1600)	2500 (1600)	5000 (3200)	
			Hours	20	80	160	160	320	
17	Moving Parts and Cables*	• Lubricate		✓	✓	✓	✓	✓	
18	Throttle Lever Housing and Cable*	• Check operation and correct if necessary. • Check throttle cable free play and adjust if necessary. • Lubricate throttle lever housing and cable.	✓	✓	✓	✓	✓	✓	
19	Front and Rear Brake Switches*	• Check operation and correct if necessary.	✓	✓	✓	✓	✓	✓	
20	Lights and Switches*	• Check operation and correct if necessary. • Adjust headlight beams.	✓	✓	✓	✓	✓	✓	
21	Drive Chain Lubrication	• Lubricate	✓	✓	✓	✓	✓	✓	

CARBURETOR: Tao Motor recommends using a fuel stabilizer at all times to prevent the buildup of residue from stale or deteriorated fuel. If the vehicle is not in operation for 20 days or more fuel residue can form in jets and passages causing the vehicle not to start.

BATTERY: The battery should be charged with a trickle charger when the vehicle is not in regular use. Otherwise, it may discharge and become damaged from sulfation. Batteries are not covered under the vehicle warranty.

For more information on service and maintenance go to www.taomotor.com

PERIODIC MAINTENANCE RECORD

MAINTENANCE INTERVAL PERFORMED	SERVICING DATE	SERVICING DEALER OR PERSON	REMARK

ENGINE OIL

The engine oil level should be checked before each ride. In addition, always follow the maintenance schedule for oil changes as shown in the maintenance schedule.

NOTE

Your new vehicle's engine comes with shipping oil, shipping oil must be changed before the engine is started for the first time. Please see specification chart for recommended oil type.

To check the engine oil level

1. Place the ATV on a level surface.
2. Check the engine oil level on a cold engine.
3. Remove the engine oil filler cap, and then wipe the engine oil dipstick off with a clean rag.
4. Slowly thread the dipstick back in the filler hole, and then remove it again to check the oil level.
5. If the engine oil is at or below the minimum level mark, add sufficient oil of the recommended type to raise it to the correct level.

NOTICE: Be sure the engine oil is at the correct level, otherwise engine damage may result.

6. Check the O-ring for damage, and replace it if necessary.
7. Insert the dipstick into the oil filler hole, and then tighten the engine oil filler cap.

TIP

If the engine was started before checking the oil level, be sure to warm up the engine sufficiently, and then wait at least ten minutes until the oil settles for an accurate reading.

TIP

The engine oil dipstick is located on the right side of the ATV behind the right foot rest.

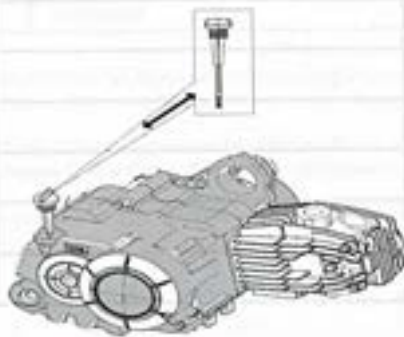

WARNING

Only add engine oil into the dipstick filler hole. Never pour engine oil anywhere else other than dipstick filler hole.

1. Minimum Oil Level Mark
2. Maximum Oil Level Mark

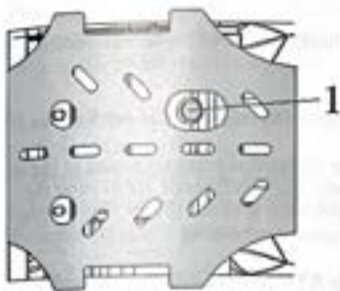

1. Engine Oil Drain Plug (17mm)

To change the engine oil

1. Place the ATV on a level surface.
2. Place an oil pan under the engine to collect the used oil.
3. Remove the engine oil filler cap, and then remove the engine oil drain bolt to drain the oil from the crankcase.
4. Reinstall O-ring and drain plug to the specified torque.(14 Nm / 10 ft/lbs).
5. Refill engine with specified amount of the recommended engine oil.
Recommended engine oil is SAE 15W40 and oil capacity is 0.8 US qt. or 0.8 liters.
6. Start the engine, and then it let it idle for a few minutes.
7. Turn off engine and check engine dip stick for correct engine oil level .

NOTICE: When removing the engine oil drain bolt the O-ring may fall out. Take care not to lose these parts.

NOTICE: Before installing the engine oil drain bolt, be sure to install the O-ring, and then engine drain bolt.

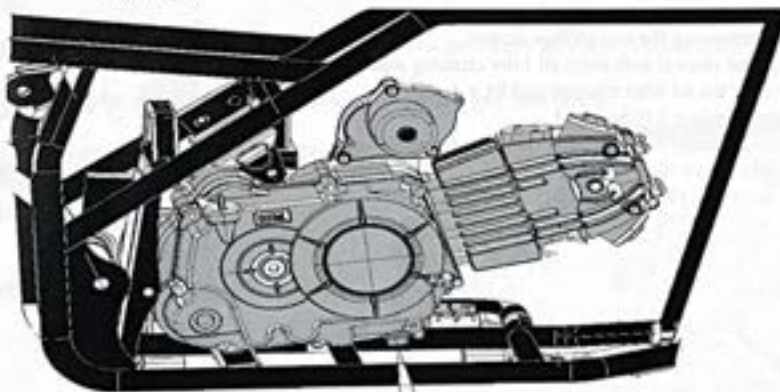

1. O-Ring
2. Drain Plug

CLEANING AIR FILTER ELEMENT

The air filter element should be serviced at the intervals specified in the periodic maintenance and lubrication chart. Clean and replace as needed. Clean and replace air filter more frequently if used in dusty or dirty areas.

⚠ WARNING

Never use low-flash-point solvents or gasoline to clean the air filter element because the engine could catch fire or explode.

NOTICE

Do not twist the air filter element when squeezing it. Make sure that the air filter element is properly seated in the air filter case. Never operate the engine with the air filter element removed. This will allow unfiltered air to enter the engine, causing rapid engine wear and possible engine damage. Additionally, operation without the air filter element will affect carburetor jetting with subsequent poor performance and possible engine overheating.

The air filter element should be cleaned every 20-40 hours. It should be cleaned and lubricated more often if the ATV is operated in extremely dusty areas. When servicing the air filter element, be sure to check the air inlet of the air filter case for obstructions.

1. Park the ATV on a level surface.
2. Remove the seat.
3. Remove the air filter cover by removing the two phillips screws.
4. Remove the air filter element and clean it with foam air filter cleaning solution.
5. Squeeze the excess solvent out of the air filter element and let it dry.
6. Check the air filter element and replace it if damaged.
7. Apply foam air filter oil or other quality foam air filter oil to the foam element.
8. Insert the air filter element into the air filter housing.
9. Install the air filter cover and the two phillips screws.
10. Install the seat.

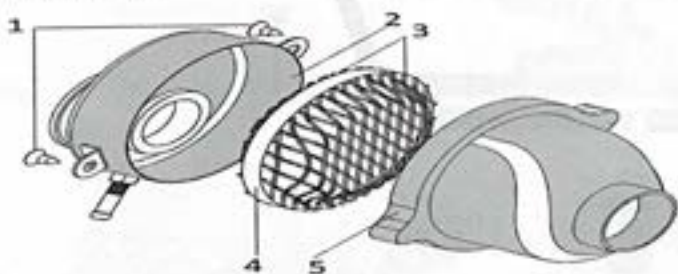

1. Air Filter Cover Screws
2. Air Filter Housing
3. Air Filter Element Screen
4. Air Filter Element
5. Air Filter Cover

SPARK PLUG

Checking the spark plug

The spark plug is an important engine component, which is easy to check. The spark plug should be removed and checked in accordance with the periodic maintenance and lubrication chart.

To remove the spark plug

1. Remove the spark plug cap.
2. Remove the spark plug as shown, with the spark plug wrench included in the owner's tool kit.
3. Turn the spark wrench counterclockwise to loosen and remove the spark plug.

To check the spark plug

1. Check that the porcelain insulator around the center electrode of the spark plug to see if it's worn out.
2. Check the spark plug for electrode erosion and excessive carbon or other deposits, and replace it if necessary.
3. Measure the spark plug gap with a wire thickness gauge and, if necessary, adjust the gap to specification.

To install the spark plug

1. Clean the surface of the spark plug gasket and its mating surface, and then wipe off any grime from the spark plug threads.
2. Install the spark plug with the spark plug wrench by turning it clockwise, to the specified torque.
3. Install the spark plug cap.

OEM manufacturer specified spark plug is either, NST / A7RTC or NGK / CR6HSA.

4. Tightening torque: Spark plug:
12 N•m (1.2 kgf•m, 8.7 lb•ft)

Spark Plug Gap:

0.06-0.085mm (0.024-0.028 in)

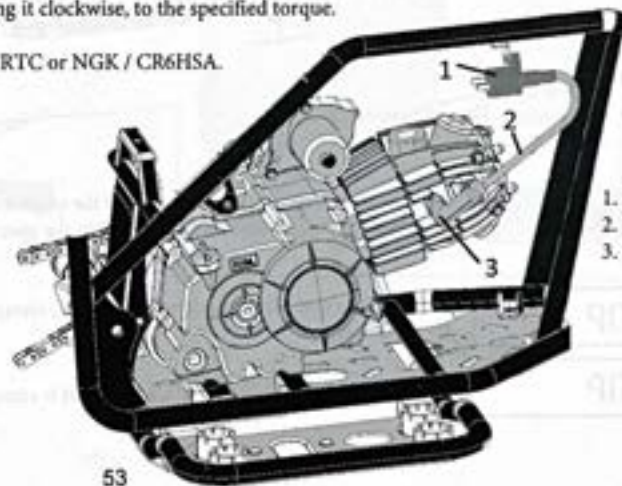

1. Ignition Coil
2. Coil Wire
3. Spark Plug Cap

DRIVE CHAIN

Checking Drive Chain Slack

The drive chain slack should be checked before each ride.

How to check for drive chain slack:

1. Place the ATV on a level surface.
2. Move the ATV back and forth to locate the tightest portion of the drive chain, and then measure the drive chain slack as shown.
3. If the drive chain slack is incorrect, adjust chain before riding ATV.

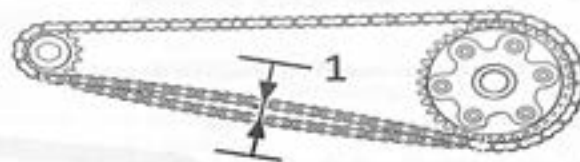

Drive chain slack:
6.0-12.0 mm (0.24-0.47 in)

1. Drive Chain Slack

NOTICE

Improper drive chain slack will overload the engine as well as other parts of the ATV. To prevent this from occurring, keep the drive chain slack within the specified limits.

TIP

when checking and adjusting drive chain slack, always check without any weight on vehicle and all tires are on even surface area.

TIP

Always use high quality all-condition lube that is compatible with all O-ring and non-O-ring chains.

DRIVE CHAIN ADJUSTMENT

To adjust the drive chain slack

1. Loosen axle carrier/housing bolts.
2. For all Tao Motor models equipped with chain tensioner, always do the following; lift and hold the chain tensioner off the chain to release chain tension until the chain adjustment is completed.

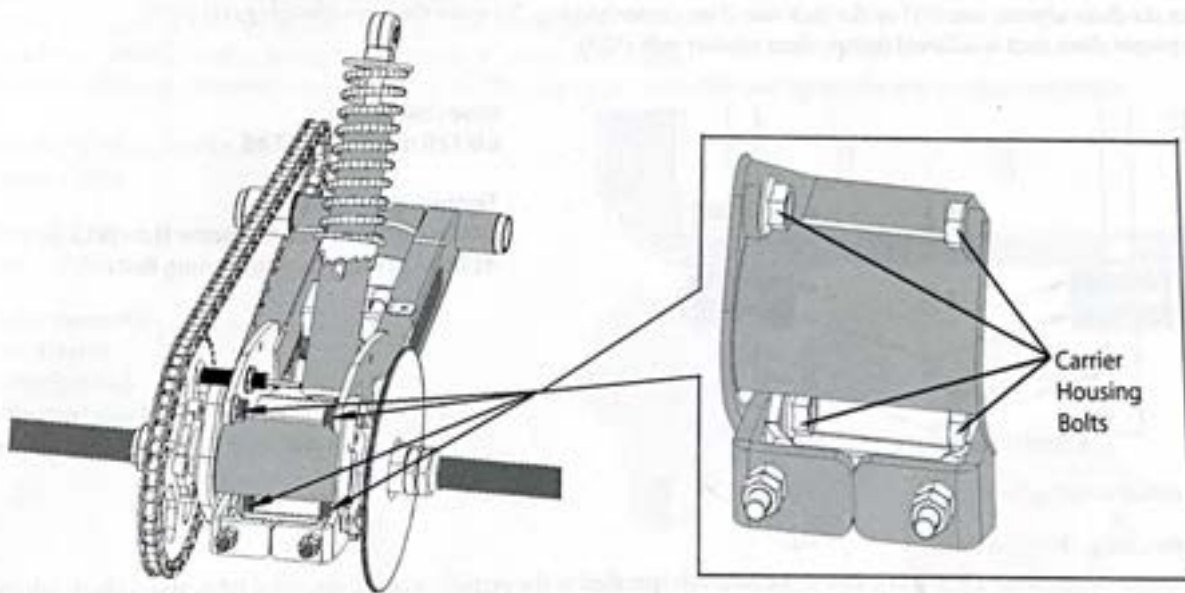

To tighten drive chain,

1. Loosen the chain adjuster nut(#1) on the back side of the carrier/housing.
2. Tighten the chain adjuster nuts(#2) to move the carrier/housing forward.
3. When proper chain slack is achieved tighten chain adjuster nuts (#1,3).

To loosen drive chain,

1. Loosen the chain adjuster nut (#1) on the back side of the carrier/housing.
2. Loosen the chain adjuster nuts (#2,3).
3. Tighten the chain adjuster nuts (#1) on the back side of the carrier/housing . To move the carrier/housing rearward.
4. When proper chain slack is achieved tighten chain adjuster nuts (#2,3).

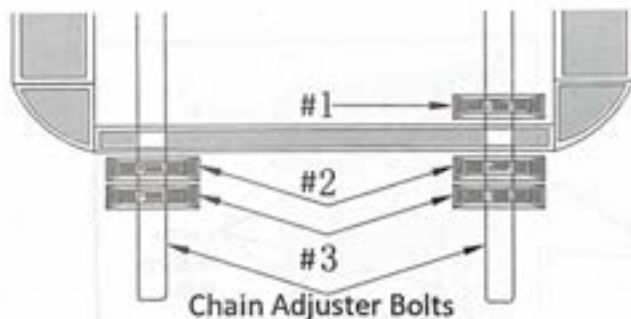

Drive chain slack:
6.0-12.0 mm (0.24-0.47 in)

Tightening Torques:
14 Nm / 10 ft/lbs Chain Adjuster Nuts (#1,2,3)
45 Nm / 33 ft/lbs Carrier/Housing Bolts

3. Tighten carrier housing bolts.

Cleaning Lubricating Drive Chain

The drive chain must be cleaned and lubricated at the intervals specified in the periodic maintenance and lubrication chart, otherwise it will quickly wear out, especially when riding in dusty or wet areas.

Service the drive chain as follows.

1. Remove all dirt and mud from the drive chain with a brush or cloth.
2. Spray chain lubricant on the entire chain, making sure that all side plates and rollers have been sufficiently oiled.

NOTICE

The drive chain must be lubricated after washing the ATV or riding in the rain or wet areas.

CLEANING SPARK ARRESTER

⚠ WARNING

Be sure the exhaust pipe and muffler are cool before cleaning the spark arrester.

1. Unscrew the 3(4mm) allen bolts (#4) securing the muffler end cap to muffler by using a 4mm allen socket wrench.
2. Unscrew the 3 Phillips screws (#5) securing spark arrester to muffler.
3. Carefully remove the spark arrester from the muffler assembly.
4. Remove accumulated carbon on the spark arrester screen with soap and water and remove hard to remove carbon carefully with a brass wire brush and then rinse and dry the spark arrester.
5. Check the spark arrester for damage, and replace it if necessary.
6. Install the 3 Phillips screws (#5) and tighten them to the specified torque.
7. Install the 3(4mm) allen bolts (#4) securing the muffler end cap to the muffler and tighten them to the specified torque.

Tightening Torque: Muffler End Cap:
6.77Nm / 5 ft/lbs

Tightening Torque: Spark Arrester Screen:
6.77Nm / 5ft/lbs

1. Muffler Assembly
2. Spark Arrester
3. Muffler End Cap
4. Muffler End Cap Bolts
5. Spark Arrester Mounting Phillips Screws

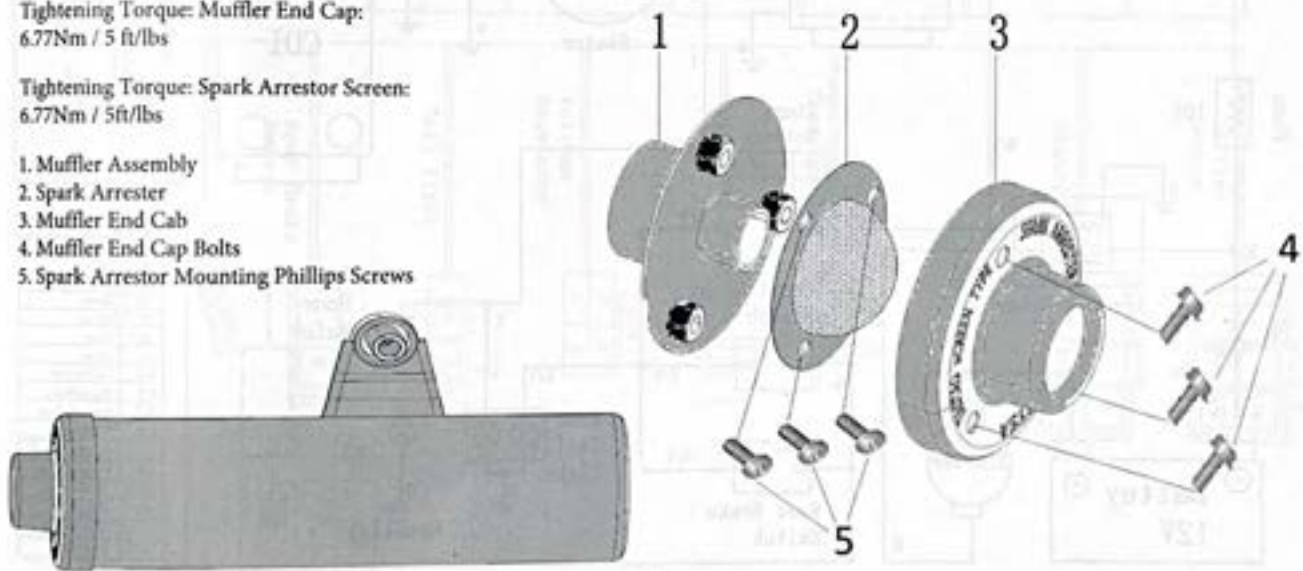

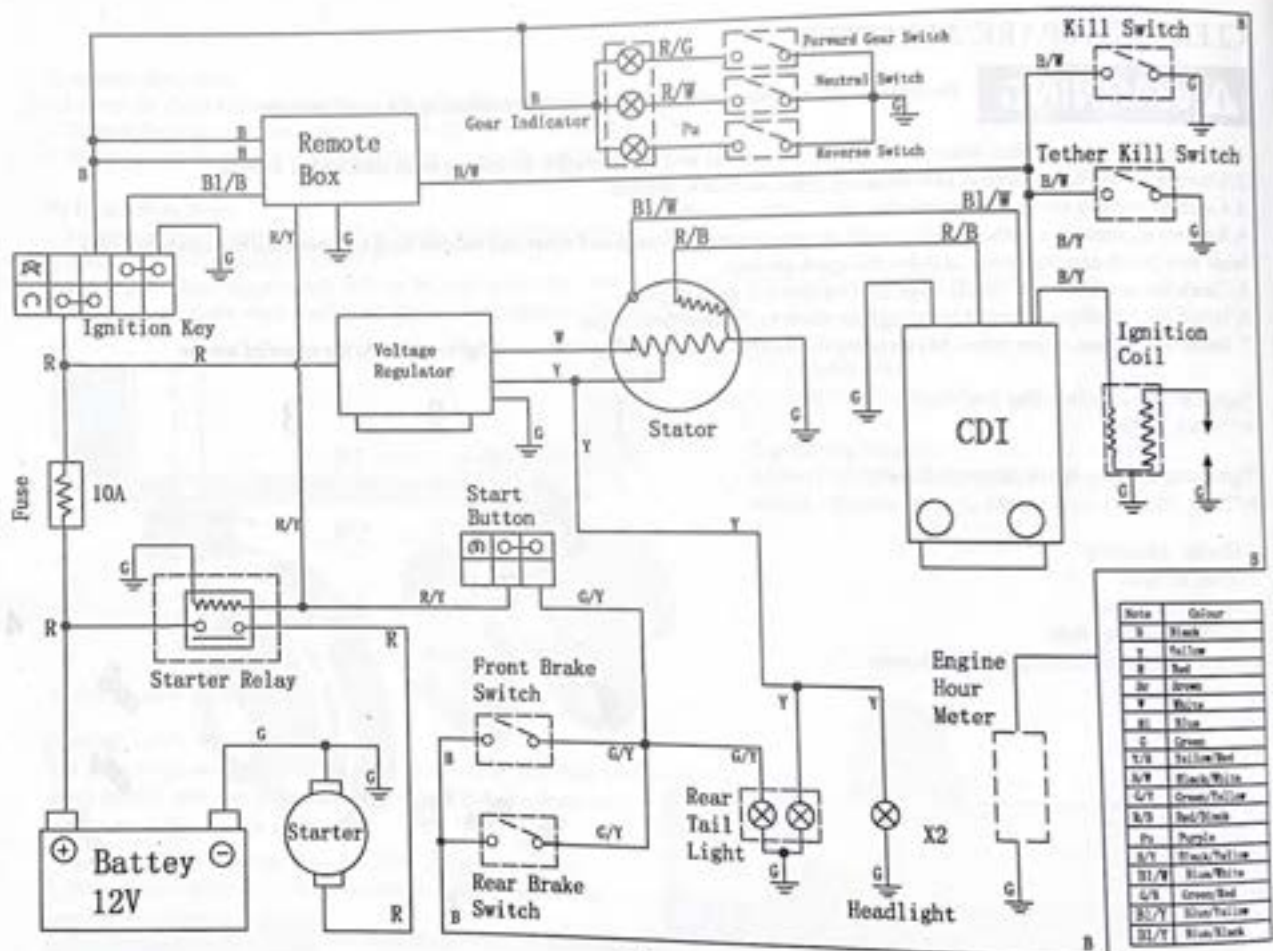

COMMONLY ASKED QUESTIONS

What kind of oil do I use?

15W-40 4-Stroke ATV Conventional Oil for Wet Clutch System.

Can I use Synthetic Oil?

Yes: 10W-40 4-Stroke ATV Full Synthetic Oil for Wet Clutch System.

How much oil do I use?

Less than one quart around 0.8 US qt or 0.8 liters.

How do I check the transmission oil or the gear box oil?

The design of this engine assembly utilizes engine oil and gear box oil all as one lubricant. No gear box / transmission oil is used just engine oil.

Why won't ATV start?

Make sure your battery is 100% charged.

Apply brake levers and push the start button at the same time to crank the engine. See page 21 for starting instructions.

Why won't the engine stay running?

Try adjusting idle screw. See page 29 for engine idle adjustment.

Where do I buy replacement parts?

You can connect your local Tao Motor dealer or www.PatsKit.com

What is the spark plug gap?

The gap is 0.06–0.085mm. See page 53.

Why is my brake light not coming on?

Try applying both brakes with ignition key in the "ON" position.

My ATV cranks but won't fire?

Ensure tether cap is pushed in firmly into tether kill switch housing. See page 21 for starting instructions.

Ensure main switch is set to "Run" position. See page 6 main switch.

Set choke lever to correct position. See page 10 choke lever.

Why won't the day time running light turn on?

The day time running light (DTRL) will only turn on when the engine is running.

Why didn't I get an assembly instruction manual?

This vehicle should only be assembled and prepped by authorized Tao Motor Dealer or professional motorcycle mechanic. You should never try to attempt assembly of this vehicle, it should be done by professionals. Death or serious injury could result from failure to follow these warnings and instructions.

EMISSION CONTROL SYSTEM WARRANTY

Below is the emission control system warranty printed in the owner's manual, the copy of the owner's manual is available upon your request.

YOUR WARRANTY RIGHTS AND OBLIGATIONS

The U.S. Environmental Protection Agency, and Tao Motor Inc. (hereinafter "Tao Motor") are pleased to explain the emission control system warranty on your 2020 Model Year ATV And Newer. New vehicle must be designed, built and equipped to meet U.S. EPA Federal emission standards over the full useful life of 10000km or 60 months which comes first.

Tao Motor must warrant the emission control system on your vehicle for 5,000 km or for 30 months, whichever comes first, provided that there has been no abuse, neglect or improper maintenance of your vehicle.

Your emission control system may include parts such as the carburetor or fuel injection system, the ignition system, catalytic converter and engine computer, if it is equipped. Also included may be hoses, belts, connectors and other emission-related assemblies. Where a warrantable condition exists, Tao Motor will repair your vehicle at no cost to you, including diagnosis, parts and labor. If an emission-related part on your vehicle is defective, the part will be repaired or replaced by Tao Motor. This is your emission control system defects warranty.

NOTICE! Use of any Tao Motor vehicles in any type of competitive event completely and absolutely voids this and all other warranties offered by Tao Motor.

OWNER'S WARRANTY RESPONSIBILITIES

As the vehicle owner, you are responsible for the performance of the required maintenance listed in your owner's manual. Tao Motor recommends that you retain all receipts covering maintenance on your vehicle, but Tao Motor cannot deny warranty solely for the lack of receipts or for your failure to ensure the performance of all scheduled maintenance.

You are responsible for presenting your vehicle to the Tao Motor's dealer as soon as a problem exists. The warranty repairs should be completed in a reasonable amount of time, not to exceed 30 days.

As the vehicle owner, you should be aware that Tao Motor may deny your warranty coverage if your vehicle or a part has failed due to abuse, neglect, improper maintenance or unapproved modifications.

If you use your vehicle in any type of sanctioned competitive event, this warranty is immediately and completely void. If you have any questions regarding your warranty rights and responsibilities, you should contact

Tao Motor Inc., 2201 Luna Road, Carrollton, TX 75006, TEL: (888)908-3816

Tao Motor warrants that each new 2020 model year and newer Tao Motor's ATV:

A. is designed, built and equipped so as to conform at the time of initial retail purchase with all applicable regulations of the United States Environmental Protection Agency; and is free from defects in material and workmanship which cause such vehicle to fail to conform with applicable regulations of the United States Environmental Protection Agency for the periods specified above.

I. Coverage. Warranty defects shall be remedied during customary business hours at any authorized Tao Motor's dealer located within the United States of America in compliance with the Clean Air Act and applicable regulations of the United States Environmental Protection Agency. Any part or parts replaced under this warranty shall become the property of Tao Motor.

II. Limitations This Emission Control System Warranty shall not cover any of the following:

A. Repair or replacement as a result of

- (1) accident,
- (2) misuse,
- (3) repairs improperly performed or replacements improperly installed,
- (4) use of replacement parts or accessories not conforming to Tao Motor's specifications which adversely affect performance and/or
- (5) use in competitive racing or related events.

B. Inspections, replacement of parts and other services and adjustments required for required maintenance.

C. Any vehicle equipped with an odometer or hour meter on which the odometer mileage or hour meter reading has been changed so that actual mileage cannot be readily determined.

III. Limited Liability

A. The liability of Tao Motor under this emission control system warranty is limited solely to the remedying of defects in material or workmanship by an authorized Tao Motor's dealer at its place of business during customary business hours. This warranty does not cover inconvenience or loss of use of the vehicle or transportation of the vehicle to or from the Tao Motor's dealer. Tao Motor shall not be liable for any other expenses, loss or damage, whether direct, incidental, consequential or exemplary arising in connection with the sale or use of or inability to use the vehicle for any purpose. Some states do not allow the exclusion or limitation of any incidental or consequential damages, so the above limitations may not apply to you.

B. No express emission control system warranty is given by us except as specifically set forth herein. Any emission control system warranty implied by law, including any warranty of merchantability or fitness for a particular purpose, is limited to the express emission control system warranty terms stated in this warranty. The foregoing statements of warranty are exclusive and in line of all other remedies. Some states do not allow limitations on how long an implied warranty lasts so the above limitations may not apply to you.

C. No dealer is authorized to modify this Tao Motor Limited Emission Control System Warranty.

IV. Legal Rights. This warranty gives you specific legal rights, and you may also have other rights which vary from state to state.

V. This emission control system warranty is in addition to the standard limited warranty for all vehicles.

VI. Additional Information. Any replacement part that is equivalent in performance and durability may be used in the performance of any maintenance or repairs. However, Tao Motor is not liable for these parts. The owner is responsible for the performance of all Required maintenance. Such maintenance may be performed at a service establishment or by any individual. The warranty period begins on the date the motorcycle is delivered to an ultimate purchaser.

Tao Motor Inc.
2201 Luna Road, Carrollton, TX 75006 U.S.A
TEL:(214)635-3980 FAX: (214) 635 3985