

Owner's Manual

154F 156F 156F-1

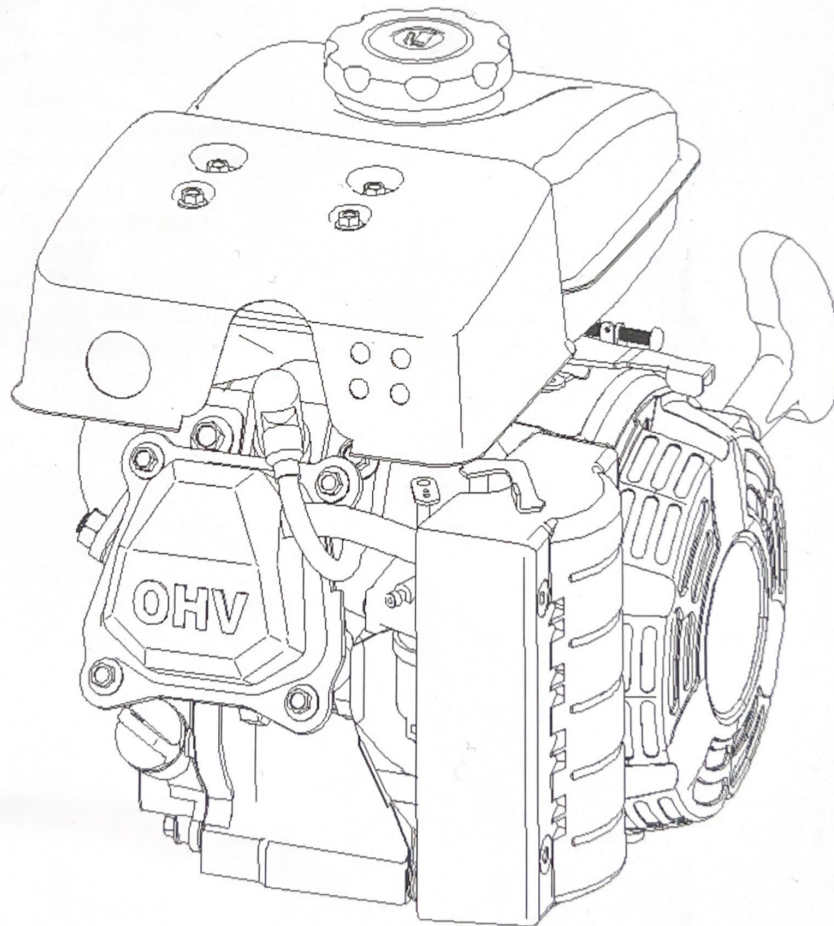

★ ★ ★ ★ ★ ★ ★ ★ ★ ★
VMC
CHINESE PARTS
YOUR 10 STAR PARTS CONNECTION
ATVs - Go Karts - Scooters - Dirt Bikes -UTVs
vmchineseparts.com - 618-529-2593

CONTENTS

CONTENTS

1. ENGINE SAFETY.....	2
2. COMPONENTS & CONTROL LOCATIONS.....	3
3. CONTROLS.....	4
Engine switch	
Choke lever	
Recoil starter	
Governor lever	
4. CHECK BEFORE OPERATION	6
Check	
Check oil	
Check fuel	
Check air cleaner	
5. STARTING ENGINE.....	8
6. STOP ENGINE	10
7. MAINTENANCE	11
Schedule	
Renewing engine oil	
Maintaining air cleaner	
Spark plug	
Adjusting idle speed	
8. STORAGE	16
9. TROUBLESHOOTING	17
10. ENGINE PARAMETER.....	20
11. WIRING DIAGRAMS.....	21

ENGINE SAFETY

1. ENGINE SAFETY

IMPORTANT SAFETY INFORMATION

Most accidents with engines can be prevented if you follow all instructions in this manual and on the engine. Some of the most common hazards are discussed below, along with the best way to protect yourself and others.

Owner Responsibilities

- The engines are designed to give safe and dependable service if operated according to instructions. Read and understand this owner's manual before operating the engine. Failure to do so could result in personal injury or equipment damage.
- Know how to stop the engine quickly, and understand the operation of all controls. Never permit anyone to operate the engine without proper instructions.
- Do not allow children to operate the engine. Keep children and pets far away from the area of operation.

Refuel With Care

Gasoline is extremely flammable, and gasoline vapor can explode. Refuel outdoors, in a well-ventilated area, with the engine stopped. Never smoke near gasoline, and keep other flames and sparks away. Always store gasoline in an approved container. If any fuel is spilled, make sure the area is dry before starting the engine.

Hot Exhaust

- The muffler becomes very hot during operation and remains hot for a while after stopping the engine. Be careful not to touch the muffler while it is hot. Let the engine cool before storing it indoors.
- To prevent fire hazards and to provide adequate ventilation for stationary equipment applications, keep the engine at least 3 feet (1 meter) away from building walls and other equipment during operation. Do not place flammable objects close to the engine.

Carbon Monoxide Hazard

Exhaust gas contains poisonous carbon monoxide. Avoid inhalation of exhaust gas. Never run the engine in a closed garage or confined area.

COMPONENTS & CONTROL LOCATIONS

2. COMPONENTS & CONTROL LOCATIONS

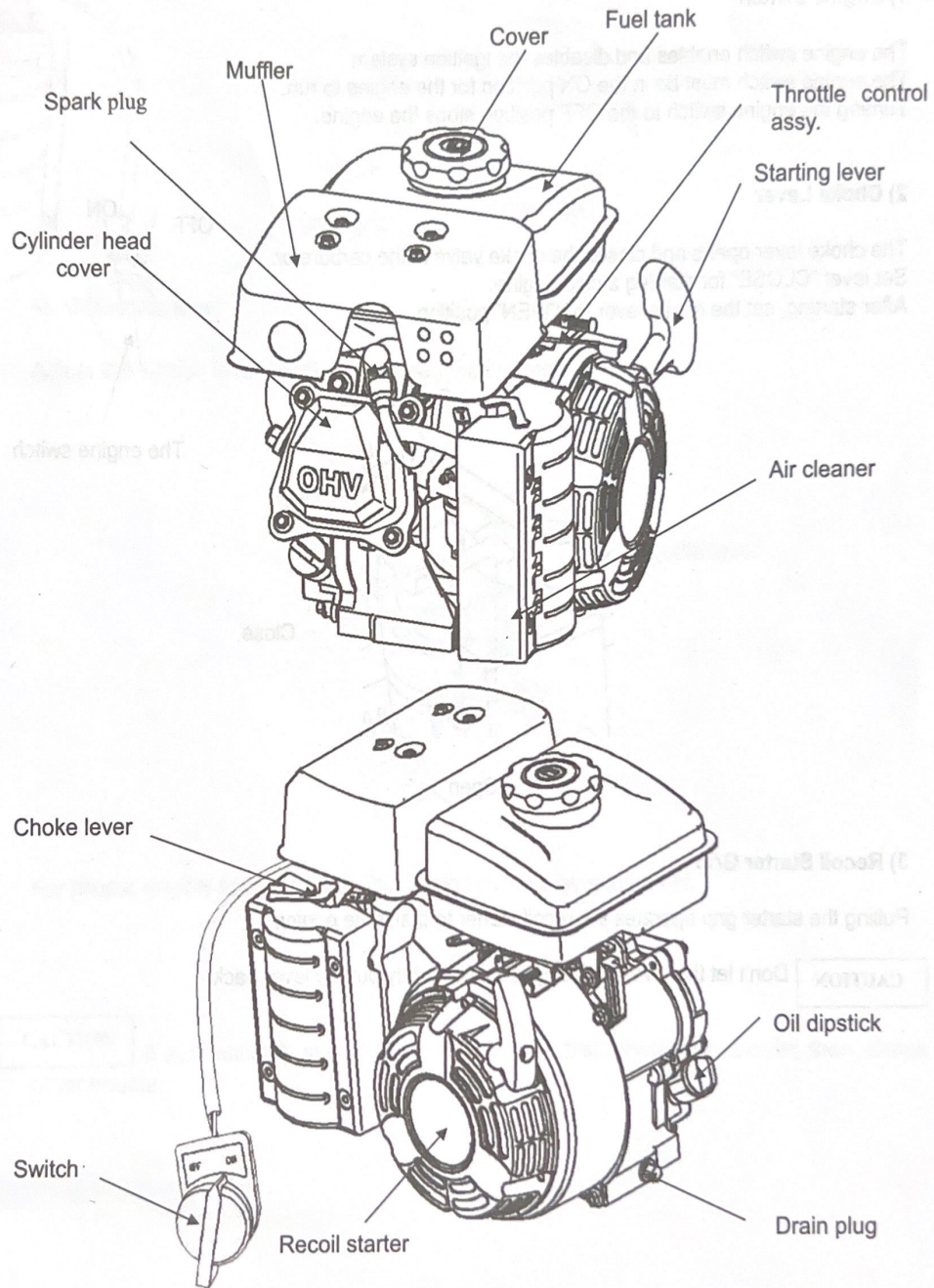

CONTROLS

3. CONTROLS

1) Engine Switch

The engine switch enables and disables the ignition system.
The engine switch must be in the ON position for the engine to run.
Turning the engine switch to the OFF position stops the engine.

2) Choke Lever

The choke lever opens and closes the choke valve in the carburetor.
Set lever "CLOSE" for starting a cold engine.
After starting, set the choke lever to "OPEN" position

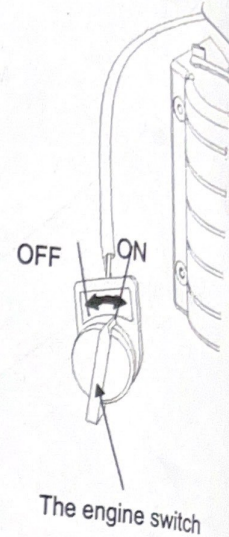
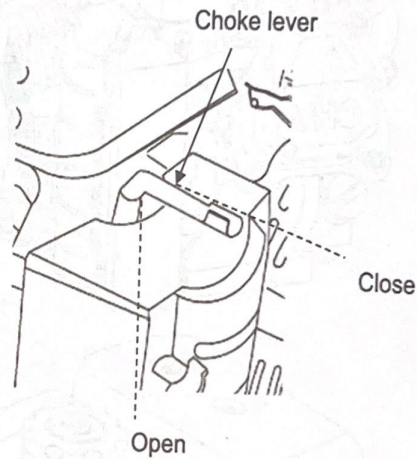

3) Recoil Starter Grip

Pulling the starter grip operates the recoil starter to crank the engine.

CAUTION Don't let the lever suddenly rebound, lightly put the lever back.

OPERATION CONTROLS

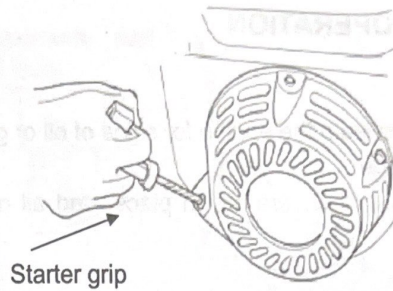

4) Governor lever

Adjust the throttle lever position to get required speed.

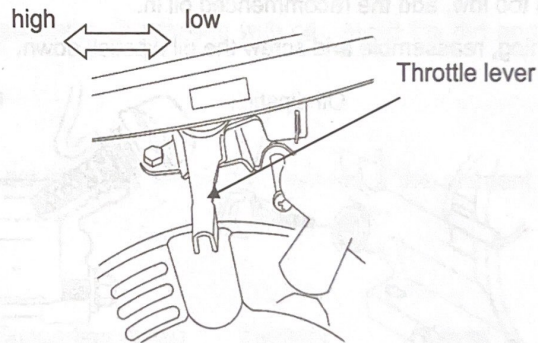

For proper engine speed, refer to indication provided by equipment.

CAUTION

If automatically stopping and not starting, first, check the oil lever, then, check other trouble.

CHECK BEFORE OPERATION

4. CHECK BEFORE OPERATION

1) Check

- Look around and underneath the engine for signs of oil or gasoline leaks.
- Look for signs of damage.
- Check that all shields and covers are in place, and all nuts, bolts, and screws are tightened.

2) Check oil

CAUTION

When stopping the engine at horizontal place, check the oil

- 1) Take the oil dipstick and clean
- 2) Insert the oil dipstick in and check the oil level without screwing down.
- 3) If the oil is too low, add the recommended oil in.
- 4) After finishing, reassemble and screw the oil dipstick down.

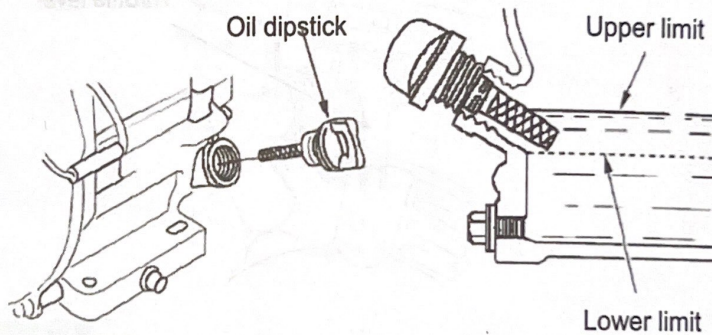

The Oil Alert system (applicable engine types) will automatically stop the engine before the oil level falls below safe limits. However, to avoid the inconvenience of an unexpected shutdown, always check the engine oil level before startup.

3) Check fuel

First stop the engine, open the fuel cover, and check oil level., if the oil level is too low, add the fuel to full, after finishing, screw the fuel cover down.

Don't add the fuel over the shoulder of the carburetor when fueling (maximum oil level).

Fuel tank volume:

154F-1: 1.6 L

CHECK BEFORE OPERATION

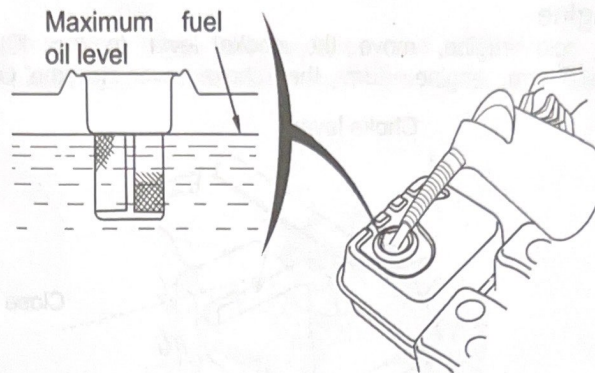

Recommended octane rating over 90 unleaded gasoline
For unleaded gasoline, can make carbon deposit much less and enhance exhaust system service life

Don't use used and contaminated or gasoline with oil , Avoid the dirt and water entering into fuel tank.

4) Check air cleaner

Remove the air cleaner housing and check the element, if the element dirt, clean it, if damaged, renew.

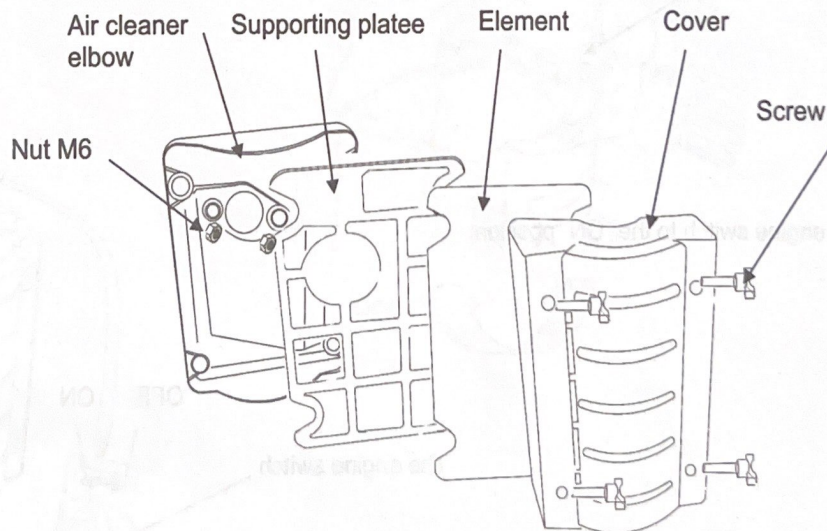

Starting engine

5. Starting engine

- 1) To start a cold engine, move the choke lever to the "CLOSE" position.
To start a warm engine, turn the choke lever to the "OPEN" position.

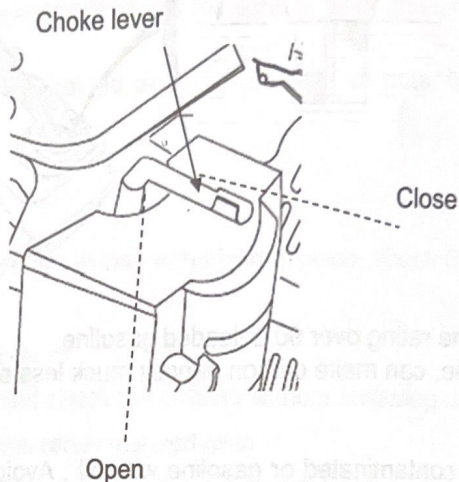

- 2) Move the throttle lever away from the "LOW" position, about 1/3 of the way toward the "HIGH" position.

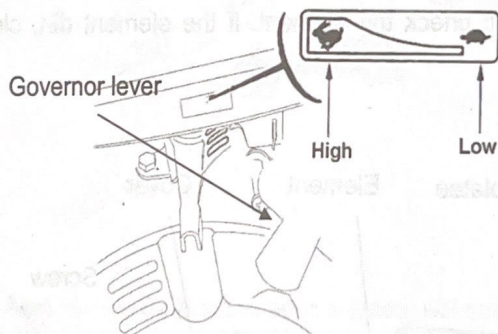

- 3) Turn the engine switch to the "ON" position.

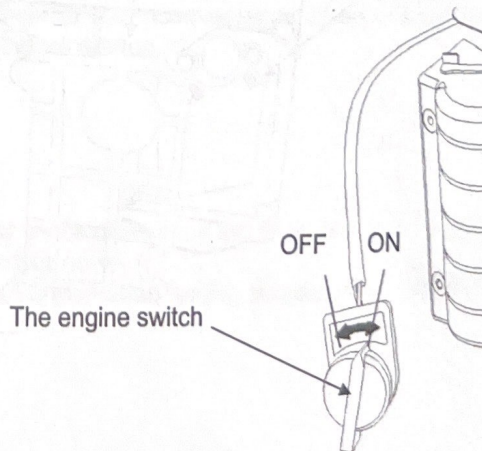

Starting engine

- 4) Pull the starter grip lightly until you feel resistance, then pull briskly.

CAUTION Don't let starting lever suddenly rebound, and lightly put the lever back.

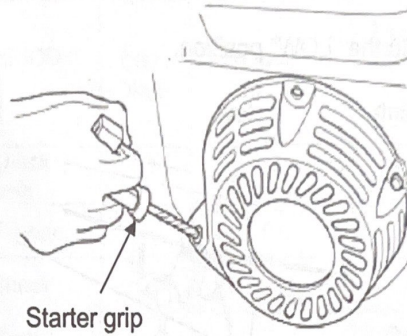

- 5) If the choke lever has been moved to the "CLOSE" position to start the engine, gradually move it to the "OPEN" position as the engine warms up.

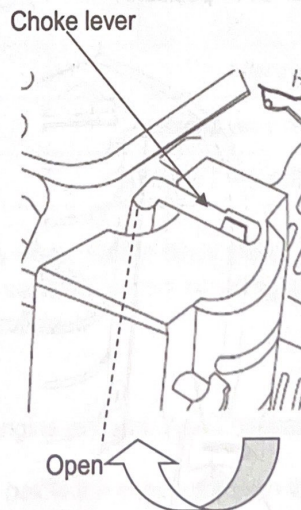

STOPPING THE ENGINE

6. STOPPING THE ENGINE

To stop the engine in an emergency, simply turn the engine switch to the "OFF" position. Under normal conditions, use the following procedure.

- 1). Move the throttle lever to the "LOW" position.

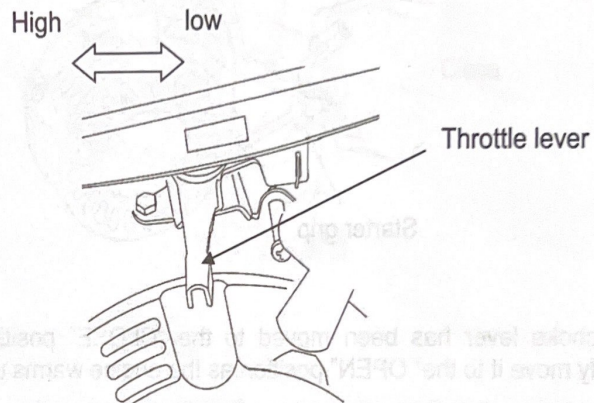

- 2) Turn the engine switch to the "OFF" position.

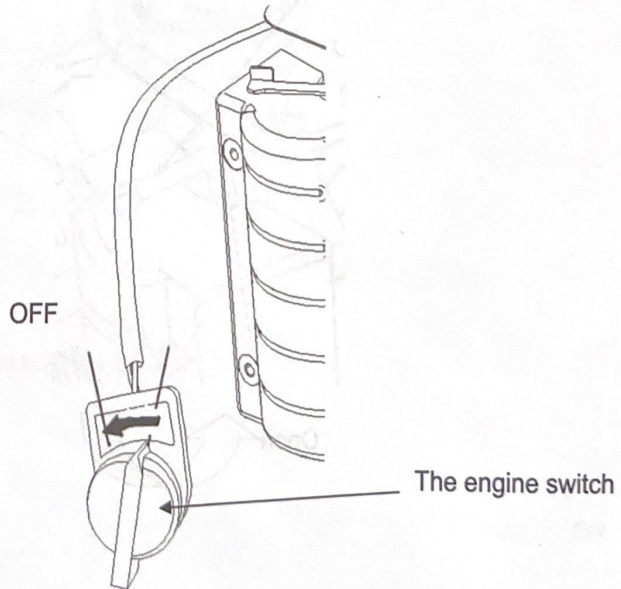

MAINTENANCE

7. MAINTENANCE

SCHEDULE

REGULAR SERVICE PERIOD		Each use	First month or 20 Hrs.	Every 3 months or 50 Hrs.	Every 6 months or 100 Hrs.	Every year or 300 Hrs.
Engine oil	Check level	○				
	Change		○		○	
Air cleaner	Check	○				
	Clean			○(1)		
	Replace					
Sediment Cup	Clean				○	
Spark plug	Clean				○	Replace
Valve clearance	Check-Adjust					○(2)
Cover comp head	Clean	After every 300 Hrs. (2)				
Fuel tank and fuel filter	Clean	Every 2 years (Replace if necessary) (2)				
Fuel line	Check	Every 2 years (Replace if necessary) (2)				

- (1) Service more frequently when used in dusty areas.
- (2) These items should be serviced by your servicing dealer unless you have the proper tools and are mechanically proficient.

RENEWING ENGINE OIL

Drain the used oil while the engine is warm. Warm oil drains quickly and completely.

- Place a suitable container below the engine to catch the used oil, and then remove the pad and dipstick and the drain plug.
- Allow the used oil to drain completely, and then reinstall the drain plug and pad, and tighten it securely.

Please dispose of used motor oil in a manner that is compatible with the environment. We suggest you take used oil in a sealed container to your local recycling center or service station for reclamation. Do not throw it in the trash; pour it on the ground; or down a drain.

- With the engine in a level position, fill to upper limit with the recommended oil.

MAINTENANCE

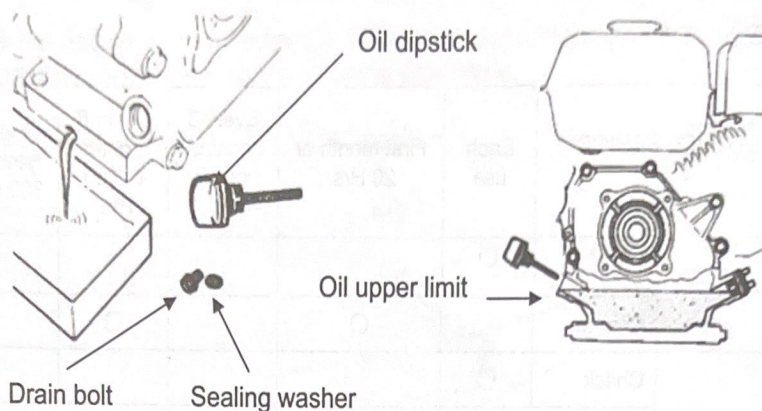

Engine oil capacities:
LC154F-1: 0.35 L

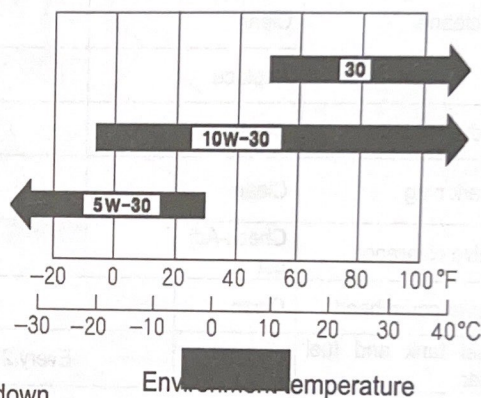

4) Assembling oil dipstick and screwing down

Recommended oil:

Use 4-stroke automotive detergent oil.

We recommend that you use API SERVICE Category SE or SF oil or equivalent to SG grade SAE 10W-30.

You can use this brand oil if your area temperature list within some brand oil temperature range

MAINTAINING AIR CLEANER

A dirty air filter will restrict air flow to the carburetor, reducing engine performance.

If you operate the engine in very dusty areas, clean the air filter more often than specified in the MAINTENANCE SCHEDULE.

NOTICE

Operating the engine without element or with a damaged element will allow dirt to enter the engine, causing rapid engine wear.

MAINTENANCE

Air cleaner

- 1) Screw off air cleaner bolt and remove the cover.

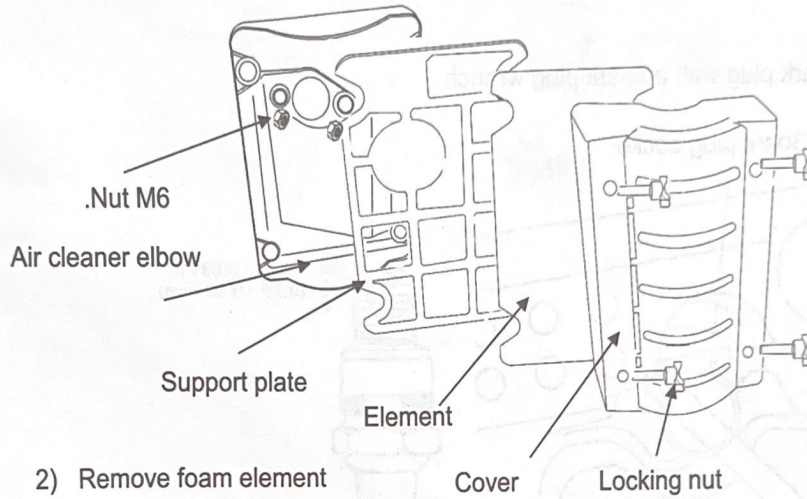

- 2) Remove foam element

Check element and renew if damaged.

Wash foam element:

Wash the cover and filter in warm, soapy water, rinse, and allow drying thoroughly. Or clean in nonflammable solvent and allow drying. Dip in clean engine oil, and then squeeze out all excess oil.

1. Empty the used oil from the air cleaner case, wash out any accumulated dirt with nonflammable solvent, and dry the case.
- 3) Clean the air cleaner I, cover and rubber gasket, preventing dust entering into carburetor.
- 4) Reassemble the foam element, paying attention to rubber gasket underneath the element.
- 5) Reassemble the air cleaner, and tighten the wing nut securely.

MAINTENANCE

SPARK PLUG

Recommended spark plugs: E7RTC or other equivalents.

NOTICE

An incorrect spark plug can cause engine damage.

1. Disconnect the spark plug cap, and remove any dirt from around the spark plug area.
2. Remove the spark plug with a spark plug wrench.

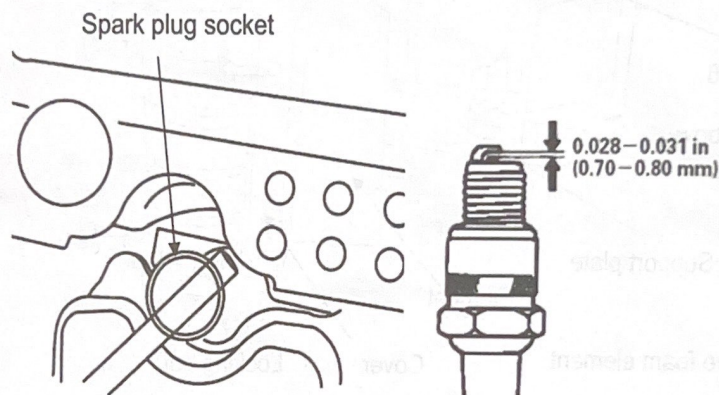

3. Inspect the spark plug. Replace it if the electrodes are worn, or if the insulator is cracked or chipped. The gap should be 0.028 - 0.031 in (0.70 - 0.80 mm). Correct the gap, if necessary.
4. Install the spark plug carefully, by hand, to avoid cross-threading.
5. After the spark plug seats, tighten with a spark plug wrench to compress the water.
If reinstalling the used spark plug, tighten 1/8 - 1/4 turn after the spark plug seats.
If installing a new spark plug, tighten 1/2 turn after the spark plug seats.

6. Assemble spark plug.

ADJUSTING IDLE SPEED

1. Start the engine outdoors, and allow it to warm up to operating temperature.
2. Move the throttle lever to its slowest position.
3. Turn the idle speed screw to obtain the standard idle speed.

MAINTENANCE

Standard idle speed: $1,800 \pm 150$ rpm

Screw

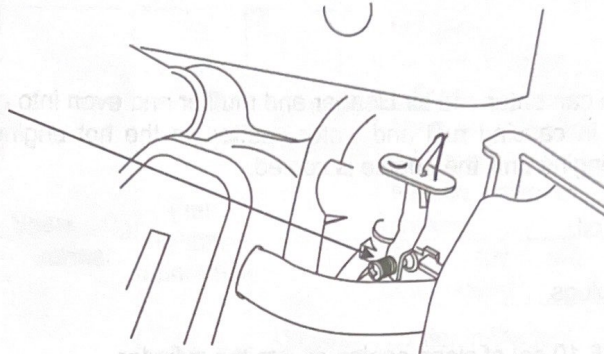

STORING YOUR ENGINE

8. STORING YOUR ENGINE

If the engine has been running, allow it to cool for at least half an hour before cleaning. Clean all exterior surfaces, repair any damaged paint, and coat other areas that may rust with a light film of oil.

CAUTION

Water with big pressure can enter into air cleaner and muffler and even into cylinder along with air path, resulting in causing rust and water spatter on the hot engine to damage engine, so don't wash engine until the engine is cooled.

- 1) Change the engine oil.
- 2) Remove the spark plugs.
- 3) Pour a tablespoon (5-10 cc) of clean engine oil into the cylinder.
- 4) Pull the starter rope several times to distribute the oil in the cylinder.
- 5) Reinstall the spark plugs.
- 6) Pull the starter rope slowly until resistance is felt. This will close the valves so moisture cannot enter the engine cylinder. Return the starter rope gently.
- 7) Put the out case on the engine and place in the ventilated and dry area.

Troubleshooting

9. Troubleshooting

1) Starting difficult

Phenomenon	Possible Cause			Correction		
Cylinder pressure normal	Spark plug normal	Fuel system abnormal	Oil path unpassing	No fuel	Add fuel	
				Air hole clogged	Clean clogged	
				Oil cock clogged	wash	
				Main jet adjusted not well, or clogged	Readjust, wash and blow	
			Needle valve or float blocked.	Repair or renew		
			Oil path passing	Fuel too dirt or deteriorated	Renew fuel or clear carburetor	
				Water in the fuel	Renew fuel and clean carburetor	
	Too much fuel in the cylinder	Drain fuel and clean spark plug				
	Fuel system normal	Spark normal	Spark plug poor	Wrong fuel	Chang fuel	
				Carbon deposit and dirt electrode	Clean carbon deposit and dirt	
				Damaged insulator	Renew spark plug	
				Electrode burn through.	Renew spark plug	
				Wrong gap	Adjust gap	
				Spark normal	No spark	High tension coil damaged
Igniter coil damaged						Renew high tension coil
Magnetic field strength not enough	Charge magnetic or renew					
Cylinder pressure abnormal	Fuel system normal	Igniter normal	Spark plug normal	Piston ring worn or broken.	Renew	
				Ring cementation	Clean carbon deposit	
				No washer or not tightening	Add washer or tighten	
				Leaking from joint	Renew gasket	
				valve sealing poor	Lap or renew	

Troubleshooting

2) ENGINE LACKS POWER

Phenomenon	Possible Cause		Correction
When increasing throttle speed up slowly or speed down or stop the engine	Ignition system	Ignition time not right	Replace ignition coil
	Fuel system	Fuel path with air	Exhaust air
		Wrong adjustment of main jet	Readjustment
		Needle valve and main jet clogged	Clean and blow
		Oil cock clogged	Clean or replace
		Carbon deposit in the combustion chamber	Clean carbon deposit
	Intake system	Air cleaner clogged	Clean or replace
		Intake system clogged	Repair or replace
	Compression poor	Piston, cylinder piston ring worn	replace
			Leakage between cylinder and cylinder head
		Valve gap not right	Readjustment
		Valve sealing leakage	Grinding or replacement

3) SUDDENLY STOP THE ENGINE

Phenomenon	Possible Cause		Correction
Suddenly stop in running	Fuel system	No fuel	Refuel and pass through
		Carburetor clogged	Check fuel path
		Carburetor float leaking fuel	Repair float
		Needle valve blocked	Repair
	Ignition system	Spark plugs breakdown, carbon deposit short circuit	Replace spark plug
		Spark plug electrode fallen off	Replace spark plug
		High tension line fallen off	Repair and replace
		Ignition coil breakdown	Replace
	Others	Serious scuffing and valve fallen off	Repair or replace damaged parts

Troubleshooting

4) ENGINE OVERHEATING

Phenomenon	Possible Cause	Correction
Gasoline engine overheating	Ignition time not right	Replace ignition coil
	Gasoline not enough	Refill gasoline
	Exhaust pipe clogged	Clean exhaust pipe
	Guided air shield clogged	Repair
	Air path clogged	Clean air cooling fin
	Cooling fan damaged	Reinstall
	Gas leaking from ring to down	Replace damaged parts
	Gasoline engine speed too high	Check and governor speed system or replace speed gear
	Crankshaft bearings burned	Replace or repair

5) Abnormal sound

Phenomenon	Possible Cause	Correction
Knocking sound	Piston and piston ring worn	Replace damaged parts
	Connecting rod, piston pin and pin hole worn	Replace damaged parts
	Crankshaft bearings worn	Replaces or repair
	Piston rings broken	Replace piston rings
Deflagration and metal sound	Combustion chamber carbon deposit too much	Clean carbon deposit
	Spark plug electrode gap too narrow	Adjust electrode gap
	Engine flooded with fuel	Check carburetor
	Wrong fuel	Replace fuel
	Gasoline engine overheating	Refer to overheated trouble column
Other abnormal sounds	Valve gap adjustment wrong	Readjust valve gap
	Flywheel connection with crankshaft loosen	Replace connecting key and reinstall

ENGINE PARAMETER

10. ENGINE PARAMETER

Model	154F	156F	156F-1
Type	Single cylinder 4-Stroke Forced air cooling OHV		
Rated power (kW/3600rpm)	1.5Kw/3600rpm	1.6Kw/3600rpm	1.8Kw/3600rpm
Max torque N·m/rpm	4.0N.m/2500rpm	4.5N.m/2500rpm	4.5N.m/2500rpm
Fuel consumption ratio (g/kW·h)	≤450		
Idle speed (rpm)	1600±150		
Speed fluctuating ratio	≤10%		
Noise ≤ dB(A)	93		
Bore×Stroke mm	54×38	56×38	56×40
Displacement cc	87	94	98
Compression ratio	8:0:1		
Lubricating mode	Splash		
Starting mode	Recoil start		
Rotation	Anti-clockwise(from P.T.O.Side)		
Valve clearance mm	Intake valve 0.10-0.15 Exhaust valve 0.15-0.20		
Spark plug gap mm	0.7~0.8		
Ignition mode	Transistorized magneto ignition		
Air cleaner	Single element		
Dimension mm	Length	300	
	Width	270	
	Height	310	
Net weight kg	10.5	10.5	11

WIRING DIAGRAMS

11. WIRING DIAGRAMS

Non-electric starting engine with oil protection system

Engine switch WIRING

	IG	E	ST	BAT
OFF	○—○			
ON				
START			○—○	

