

# OWNER'S MANUAL ALL TERRAIN VEHICLE

## ATV-3050C

(70cc 90cc 110cc)

### **▲ WARNING**



Operation of this ATV by children under the age of 16 increases the risk of severe injury or death.  
Do not permit children under age 16 to operate this ATV.



★ ★ ★ ★ ★ ★ ★ ★ ★ ★  
**VMC**  
CHINESE PARTS  
YOUR 10 STAR PARTS CONNECTION  
ATVs - Go Karts - Scooters - Dirt Bikes - UTVs  
vmchinese.com - 618-529-2593

## **WARNING**

- **Warning is signal that lets people know the possible risks and tells people who drive this vehicle to operate by following the right instructions to avoid accidents.**
- **Operation of this ATV by children under the age of 12 increase of the risk of severe injury or death**
- **An adult supervision required always.**
- **Never permit children under age 12 to operate this ATV**
- **Overloading can adversely affect vehicle handling**
- **Operator use only, passengers prohibited**
- **This vehicle is designed and manufactured for OFF-ROAD use only.**
- **Driving on public streets, roads or highways is illegal.**
- **Always wear helmet and other protective equipment.**
- **Do not operate this vehicle after consuming Alcohol or Drugs.**
- **Gasoline is flammable, when refueling. Please shut off engine. to avoid sparks and open flame.**
- **Read owner's manual carefully before riding. Keep owner's manual with vehicle.**
- **Because after running and the exhaust muffler very hot, vehicles should be parked in child care and others not likely to encounter.**

# SAFETY FOREWORD

Thank you for choosing Coolster Vehicles, courtesy of MAXTRADE LLC.

We have prepared this manual to help familiarize you with the procedures for operating, caring, and maintaining your Coolster vehicle. It is HIGHLY recommended that you read all information within this manual before operation of this vehicle. Thoroughly reading this manual would greatly minimize the risk of injury and damage.

It is also highly recommended that beginners seek training from their dealers or locate a qualified instructor on how to operate this vehicle. If you have any questions regarding safety or training enrollment, please call MAXTRADE LLC at 626-228-0251. For training purposes, please call ASI at 800-887-2887. We also have an after-hours safety hotline at 800-307-3429.

Thank you once again for choosing Coolster products. We wish you many years of safe and pleasant riding.

# PAY ATTENTION TO YOUR SAFETY

## Table of Contents

Pay attention to your security.....	P4
Guidelines on safe driving.....	P7
Description.....	P8
ATV recognition.....	P13
Control functions.....	P14
Before the inspection operation .....	P16
Important elements operation and rides.....	P22
Regular maintenance and minor repairs.....	P25
Cleaning and storage.....	P43
Install process after packaging.....	P46
Main specs.....	P51
Electric diagram.....	P55

## **PAY ATTENTION TO YOUR SAFETY**

ATV is not a toy, driving may cause danger. The operation of ATV is different from other motorcycles、automobiles and so on vehicles. If don't adopt right counter measures, even in right usage(such as turning、mountain roads、obstacles),can be easily rollover or collision.

Please drive according to the operation rules, or will bring serious damage or death:

1. Read carefully the instruction and all the labels,drive according to the procedure
2. Contact with the local agency, search the training courses nearby, carry on training. Don't drive until right guidance.
3. Children below 12 years old can not drive this ATV, for this ATV is not for children below 12 years old.
4. Can not carry people
5. Do not drive on paved roads, including sidewalk、lane、packing and street
6. Do not drive on public streets、roads、highway(even made of sand and stone)
7. When driving, please wear suitable certificated helmet、eye protection device(goggle or face cover)、gloves、boots、long-sleeved shirt and long sleeve pants
8. Do not drink wine or take medicine before or in driving
9. Do not speeding. To the allowing scope of the terrain, visibility,operational experience, drive in uniform speed.
10. Do not use this vehicle for the balance of technology, jumping and other stunts.

11. Check ATV before using every time, make sure it is in safe situation, operate the inspection, maintenance method and time table in the instructions

12. When driving, do not put one hand away with handle bar or one leg away with seat

13. Slow down and pay more attention when driving in unfamiliar terrain. Pay attention to the changes of terrain.

14. Do not drive on bumpy, wet, soft places, unless they have mastered driving skills and put into practice in such places, always alert in such terrain.

15. When turning, operate according to the relevant knowledge in manuals. Try to high-speed turns, be sure to carry turning training in the low-speed. Do not speed when turning.

16. Do not drive in the slope which is too steep, exceeding the ATV and your allowed skills. First train in the flat slope before trying to drive in more steep slope

17. In climbing, always use in proper procedures according to the requirements in instructions. Carefully observe the terrain before climbing, carefully climb in slippery or soft terrain. Driving on the way, keep the body center of gravity forward, do not suddenly full-throttle or shift. Do not speed when climbing the peak.

18. When brake in declivity and ramp, always use according to correct procedures required in instruction. Carefully observe terrain before downhill, keep center of gravity backwards. Do not high-speed downhill. Avoid turning when downhill (may ATV lead to a sharp tilt to one side), walk straight as much as possible.

19. When drive to the hillside, always use properly according to correct procedures required in instructions. Avoid over-smooth or soft terrain, in accordance with the rules mentioned in manuals. Center of gravity to the high side. With the slope driving, do not spin until master turning skills on flat roads described in the manuals.

20. During climbing, if want to turn off or reverse, pay attention to use the correct method. When climbing, avoid the engine stall, use correct gear and maintain a stable speed. If you want to turn off or reverse, do as the brake programs required in the manuals. Get off from the higher side. Start and get on the vehicle according to the instructions.

21. When driving in unfamiliar areas, pay attention to obstacles. Do not try to climb over large obstacles, such as large rocks or fallen trees. When over obstacles,drive carefully according to the instructions.

22. Be careful when slide or brake. Learn to control braking or sliding safely when on flat roads in low speed, such as ice surface,keeping in slow speed,carefully driving,to prevent loss of control

23. Do not drive in riptide or deep water. It is hard to brake when the plate is wet. Check the brake devices when away form water. Try to brake several times as much as possible.

24. When reverse, please ensure that no one or obstacles, behind, slow reverse.

25. Using the specified type and size of the tires in the instructions, maintain the proper tire pressure specified in the operation manuals

26. Do not reassemble the vehicle by increasing inappropriate equipment or using accessories.

27. Do not overload.

28. Do not touch the vent pipe, it's too hot after driving.

# GUIDELINES ON SAFE DRIVING

## ☆WARNING

You could be KILLED or SERIOUSLY INJURED if do not follow instruction.

1, when approaching corners or bends to reduce speed. Upon the completion of turn, may gradually increase the speed.

2, when crossing the vehicles parked in front of, to be very careful. Because the driver of the vehicle may be invisible to you and the door opened, the forward block in your way.

3, Brake Lining may Motorcycle rinsing wetting lose their role, so when cleaning End after walking ago, should check all brake system.

4, Please put dry the oil inside carburetor and the oil tank before transportation, in order to avoid jamming.

5, Transit goods please vertical put, to avoid engine oil leak.

For training please call ASI at 1-800-887-2887



**DANGER** DANGER indicates a hazardous situation which, if not avoided, will result in death or serious injury.

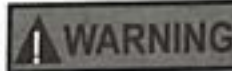

**WARNING** WARNING indicates a hazardous situation which, if not avoided, could result in death or serious injury.

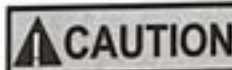

**CAUTION** CAUTION, used with the safety alert symbol, indicates a hazardous situation which, if not avoided, could result in minor or moderate injury.

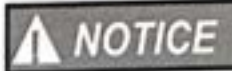

**NOTICE** NOTICE is used to address practices not related to personal injury.



# DESCRIPTION



- (1)Rear rack
- (2)Muffler
- (3)Seat
- (4)Foot brake
- (5)Engine
- (6)Key switch
- (7)Front guard

- (8)Handle bar
- (9)Fuel box
- (10)Front wheel
- (11)Rear wheel
- (12)Rear light
- (13)Rear

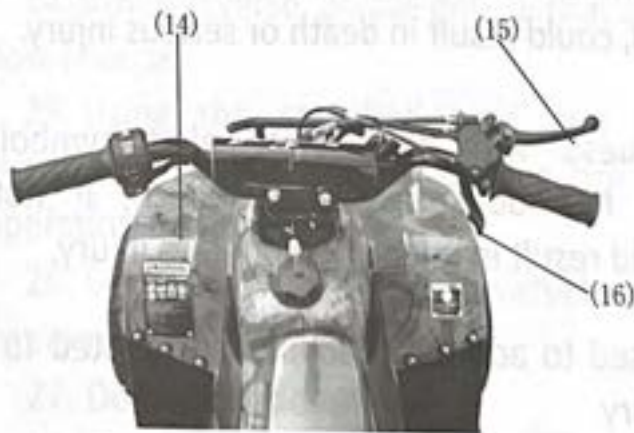

- (14)Plastic
- (15)Front brake
- (16)Greaser

# WARNING

ATV is not a toy, it may cause danger when driving. The operation of ATV is different from other motorcycles, cars and some other traffic tools. If do not take some certain protecting measures, even if in right usage, (for example turning, mountain road, or passing through the obstacles etc), it is easily lead to collision, or it may roll over.

Please drive properly as the following operation, or it may cause severe hurt or death.

- 1、 Carefully read the instruction book ( owner's manual ) and all the lables, driving according to the procedure.
- 2、 Contact with local sales agent, search for training classes nearby, and do some necessary training. You can also watch our COOLSTER ATV Safety Video for more security informations ,please do not drive this ATV until you get some appropriate guidance.
- 3、 For training please call ASI at 1-800-887-2887.
- 4、 If your label wears off from riding or becomes hard, please contact maxtrade dealer for replacement.



The warning signs with the word "WARNING" indicating the existence of the potential risks that may result in serious injury or death.

- 1、 Improper tire pressure or overloading can cause loss of control.  
Loss of control can result in sever injury or death.
  - Cold tire pressure:  
Front:14psi(96.6kPa)  
Rear:14psi(96.6kPa)
  - Maximum weight capacity:143lbs.(65kg)
- 2、 Rear rack:  
Maximum weight capacity:22 lbs (10kg)
- 3、 NEVER ride as a passenger  
Passengers can cause a loss of control,resulting in SEVERE INJURY or DEATH.
- 4、 Operation of this ATV by children under the age of 12 in creases the risk of sever injury or death.  
Adult supervision required for childre under age 16.  
NEVER permit children under age 12 to operate this ATV.
- 5、 ●.Prohibit run at max speed. Or jumping run.
  - .Please read owner s manual berore operate.and follow all instructions snd warnings.
  - .this vehicle use unleaded fuel only,please switch off rhe engine when filling to avoid or explosion.
- 6、 ●Operation of this ATV by children under the age of 12 Increase of the risk of severe injury or death.
  - An adult supervision required always.
  - Never permit children UNDER AGE 12 to operate this ATV
  - Overloading can adversely affect vehicle handling
  - Operator use only. Passengers prohibited.
  - This vehicle is designed and manufactured for OFF-ROAD use only.
  - Driving on public streels. Roads or highiays is illegal.
  - Always wear helmet and other protective equipment.
  - Do not operate this vehicie after consuming Alcohol or Drugs.
  - Gasoline is flammable. When refueling. Pls shut off-engine. to avoid sparks and open flame.
  - Read owner's maual carefully before riding.Keep owner's manual with vehcle.
- 7、 please change your engine oil after the first 300 miles and each 1.000 miles there after.Use only type 15W-40 oil Capacity of engine oil tank:0.8L.

# ATV-Safety Alert

The Consumer Product Safety Commission has concluded that ALL-TERRAIN VEHICLES (ATVs) may present a risk of DEATH or SEVERE INJURY in certain circumstances. Accidents may occur for many reasons.

- Over 4,799 people, including many children have died in accidents associated with ATVs since 2003.
- Many people have become severely paralyzed or suffered severe internal injuries as a result of accidents associated with ATVs.
- Every month thousands of people are treated in hospitals emergency rooms for injuries received while riding an ATV.

You should be aware that AN ATV IS NOT A TOY AND CAN BE HAZARDOUS TO OPERATE. An ATV handles differently from other vehicles, including motorcycles and cars. A collision or rollover can occur quickly, even during routine maneuvers such as turning and driving on hills and over obstacles, if you fail to take proper precautions.

## TO AVOID DEATH OR SEVERE PERSONAL INJURY:

- ALWAYS READ THE OWNERS MANUEL CAREFULLY AND FOLLOW THE OPERATING PROCEDURES DESCRIBED. PAY SPECIAL ATTENTION TO THE WARNINGS IN THE MANUEL AND ON ALL LABELS.
- NEVER OPERATE AN ATV WITHOUT PROPER INSTRUCTIONS. TAKE A TRAINING COURSE. BEGINNERS SHOULD COMPLETE THE TRAINING COURSE DESCRIBED BELOW.

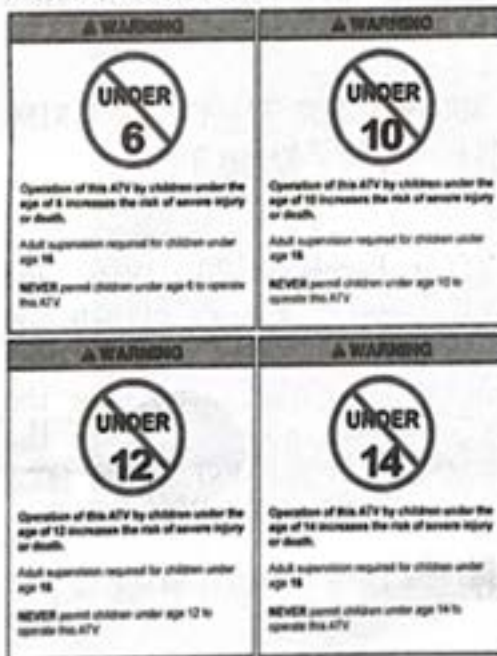

**ALWAYS FOLLOW THE MANUFACTURE'S MINIMUM AGE RECOMMENDATION WARNING LABEL ON ATV.**

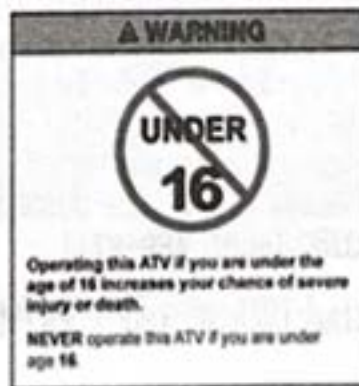

- NEVER ALLOW A CHILD UNDER 16 YEARS OLD TO OPERATE AN ATV WITHOUT ADULT SUPERVISION. CHILDREN NEED TO BE OBSERVED CAREFULLY BECAUSE NOT ALL CHILDREN HAVE THE STRENGTH, SIZE, SKILLS OR JUDGEMENT NEEDED TO OPERATE AN ATV SAFELY.

- NEVER CARRY A PASSENGER ON SINGLE-RIDER ATV. CARRYING A PASSENGER MAY UPSET THE BALANCE OF THE ATV AND MAY CAUSE IT TO GO OUT OF CONTROL.

- ALWAYS AVOID PAVED SURFACES. ATVs ARE NOT DESIGNED TO BE USED ON PAVED SURFACES AND PAVEMENT MAY SERIOUSLY AFFECT HANDLING AND CONTROL.

- NEVER OPERATE AN ATV ON A PUBLIC ROAD, EVEN A DIRT OR GRAVEL ONE, BECAUSE YOU MAY NOT BE ABLE TO AVOID COLLIDING WITH OTHER VEHICLES. ALSO OPERATING AN ATV ON A PUBLIC ROAD MAY BE AGAINST THE LAW.

- NEVER OPERATE AN ATV WITHOUT AN APPROVED MOTORCYCLE HELMET, EYE PROTECTION, BOOTS, GLOVES, LONG PANTS AND A LONG-SLEEVED SHIRT OR JACKET.

- NEVER CONSUME ALCOHOL OR DRUGS BEFORE OR WHILE OPERATING AN ATV.

- NEVER OPERATE AN ATV AT EXCESSIVE SPEEDS, GO AT A SPEED, WHICH IS PROPER FOR THE TERRAIN, VISIBILITY CONDITIONS AND YOUR EXPERIENCE.

- NEVER ATTEMPT TO DO WHEELIES, JUMPS OR OTHER STUNTS.

- ALWAYS BE CAREFUL WHEN OPERATING AN ATV, ESPECIALLY WHEN APPROACHING HILLS, TURNS AND OBSTACLES AND WHEN OPERATING ON UNFAMILIAR OR ROUGH TERRAIN.

- NEVER LEND YOUR ATV TO ANYONE WHO HAS NOT TAKEN A TRAINING COURSE OR HAS NOT BEEN DRIVING AN ATV FOR AT LEAST A YEAR.

#### Training Course

Anyone who purchased a new ATV after December 30, 1986, and everyone in the purchaser's immediate family who is within the recommended age group for the ATV purchased, is entitled to take the training course at no additional charge. Others can take the training course for a small fee. Ask an authorized dealer for the details or call (626) 228-0253 M-F 8:30PM-5:00P PST. AFTER HOUR SAFETY HOTLINE (800) 489-8711

ASI TRAINING COURSE (800) 887-2887

## ATV RECOGNITION

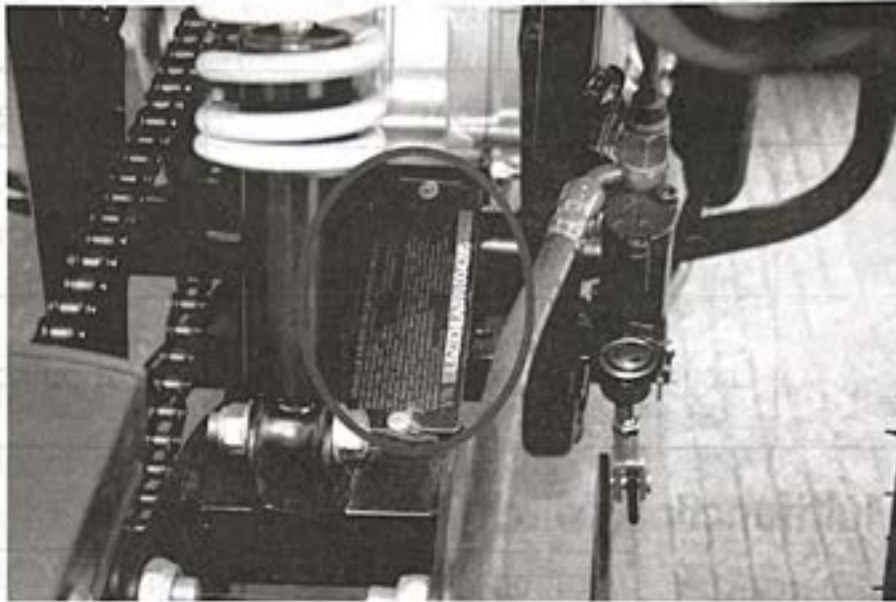



VIN plate number and product VIN (See left picture)



Engine model and serial number ( See right picture )

# CONTROL FUNTIONS





## 1、 The ignition switch

Location	Functions	Key state
	All circuits wre disconnected	Pull out
	Circuit was connected,engine starter	Not pull out

## 2、 Multifunction switch

### 1)、 Proximity switches





Location	Function
	Turn on high beam
	Turn on dipped headlight
	When press the starter switch, engine rotation
	When press the off switch, stop rotating engine

### 2)、 Starter switch

### 3)、 Off switch

## 3、 Accelerator controller



	When press this accelerator, the vehicle starts to move.
	Prohibit adjusting it.

## REMOTE CONTROL

The ATV comes equipped with a remote control which consists of a purple Flameout key and a black unlock key. An adult supervising operation of the vehicle can use the remote control to stop the engine from a short distance. The adult who trains the young rider above 12 should always use this remote control until the rider develops sufficient skills for safe operation of the vehicle.



This remote control is black and small, it's very easy to operate. There are two keys on it, one purple Flameout key and one black unlock key. If you notice any driving hazard or unsafe situation, press the purple Flameout key then the engine will stop running. When you want to start the engine again, you must press the black key first to unlock it, then you can start to move. The best distance to use this remote control is within 20m.



#### 4、 The front wheel brake handle



Front-wheel brake handle in the right hands. To handle its direction pinch Rafah as a front-wheel brake.

#### 5、 The rear brake pedal

rear-wheel brake pedal in the right pedal. To trample the pedal as a rear brake.



#### 6、 The fuel Cover

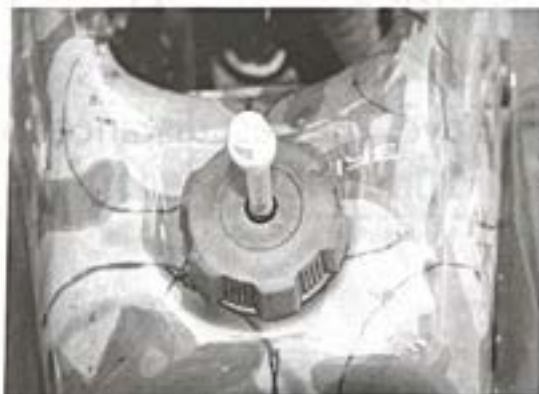

Note: the fuel Cover mouth ventilation can not plug.

## 7、Choke

Resistance carburetor throttle in the right arm. Starting cold engine needs a concentration of combustible gas concrete. In such circumstances, will be impacted throttle arm moving down. After preheating the engine will pull rod to the original starting position.

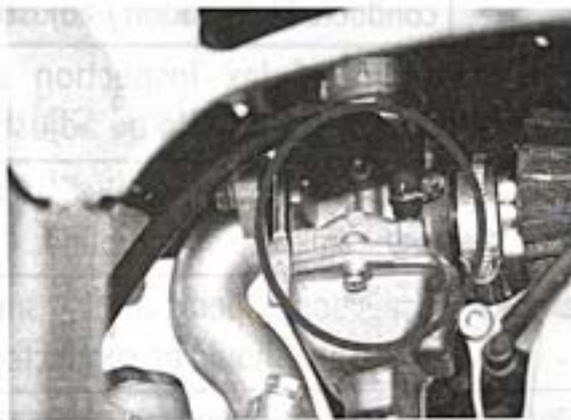

## 8、Start

Start, please go of the pinch after the brake handle, then press the start switch.



# BEFORE THE INSPECTION OPERATION

Prior to the use of the car, should check the following

Item	Normal checks
Brake	inspection operation, status and freedom itinerary. If necessary, should be adjusted. Brake Performance confirm whether the good work can be checked out at low speed.
accelerator	Check whether the smooth operation of the accelerator. If necessary, should be conducted lubrication / adjustment.
Chain - driven	chain of lax inspection and state. If necessary, should be adjusted.
Tire / wheel	checks tire pressure, wear, damage and the rate of take-up of the round.
Transmission and brake pedal shaft	inspection operation is smooth and, if necessary, should be conducted lubrication.
Brake and clutch manipulation of the handle shaft	operation of inspection, if necessary, should be conducted lubrication
The stents and stent-axis side	check whether the smooth operation, if necessary, should be conducted lubrication.
Parts / Fasteners	inspection of all parts and fasteners. If necessary, should be carried out Tightening / adjustment.
Fuel tank	inspection of the fuel oil / if necessary, should be enough fuel
battery	Check liquid level. If necessary, distilled water should be added

Warning: ● If the item prior to use in adverse conditions, should be repaired prior to use.

# DRIVERS MUST

**Fuel:** fuel compartment confirm the adequacy of fuel.

**Warning:**

- Do not add fuel tank drive. Otherwise, and in the subsequent heating and fuel inflation, the fuel will overflow.

Fuel spillage should be avoided in the hot engine

**Recommended fuel:** 90 "petrol

**Fuel tank capacity:**

**Total: 2.4 L**

## Oil:

Oil confirm whether oil at the designated place. (See left picture)  
1, the maximum oil level. 2, the lowest of oil. ( See right picture )



### Recommended oil

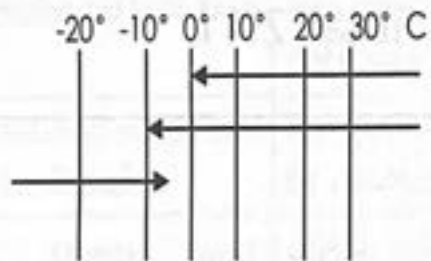

SAE 20W40 SF Engine oil  
SAE 10W30 SF Engine oil  
SAE 5W30 SF Engine oil

### Oil:

Total: 0.9 L

Regular replacement of oil: 0.8 L

Oil Filters replacement: Does deformation, damage

# TIRES

## 1. Tire pressure

Before the cars in operation, should always check and adjust tire pressure. (Tires Barometer)

## 2. Tire Inspection

Before the cars in operation, should check the tires. If excessive tire wear, to be replaced.

### Warning:

- use of the tire wear is dangerous to travel

	Size	Pressure
Front tire	16*8-7	10 ~ 24psi
Rear tire	16*8-7	10 ~ 24psi
Front tire	145/70-6	10 ~ 24psi
Rear tire	145/70-6	10 ~ 24psi

# IMPORTANT ELEMENTS OPERATION AND RIDES

## Cold Start and engine preheating

Note: This car has used to control the operation of brake motor starter switch. Only in pinch engine brake handle on when to start. We had closed choke before delivery.

1, the ignition switch will turn to the "•" position.



2, step on the rear brake pedal. (launched in order to prevent the car after forward)

3, the upward resistance throttle arm closed, not to refuel the door.

4, press the start switch.

5, the resistance after heat engine throttle arm downward completely open.

Note: If the engine can not start, should be released starting switch, wait a few seconds, then try again. Each attempt, as far as possible in a short period of time in order to protect the battery. Each starter not to exceed 5 seconds when the engine.

Note: In order to achieve maximum engine life, before moving to engine should always be preheated. Not on a Cold-engine acceleration

## Hot engine starter

When the engine has been preheated, then you do not need closure resistance throttle.

# The acceleration engine

Because the cars use Automatic Clutch. So acceleration and deceleration size only need to control the throttle on the up. According to the former right hand thumb of increased speed, deceleration is loosened.

## The commissioning Engine

0-1000 km from the motorcycle mileage during your life is very important for the period. Because the engine is new and in the meantime we must avoid prolonged Full Throttle or any situation that could be the super-engine overheating.

1,0 150 km:

Operation and avoid prolonged refueling over 1 / 4 throttle position. An hour after the operation should cease engine to cool 5 to 10 minutes.

2,150 500 km:

Operation to avoid refueling over 1 / 2 throttle position. At any time, should not be used Full Throttle operation of this vehicle.

3,500 1000 km:

To avoid refueling over 3 / 4 throttle position.

4,1000 km long and more:

Full throttle operation should be avoided. Avoid ultra-high-speed engine work.

Note: When traveling to the 300 km 500km, the oil must be replaced.

As the car had not been installed Odometer to estimate mileage can only be calculated



## The commissioning Engine

0-1000 km from the motorcycle mileage during your life is very important for the period. Because the engine is new and in the meantime we must avoid prolonged Full Throttle or any situation that could be the super-engine overheating.

1,0 150 km:

Operation and avoid prolonged refueling over 1 / 4 throttle position. An hour after the operation should cease engine to cool 5 to 10 minutes.

2,150 500 km:

Operation to avoid refueling over 1 / 2 throttle position. At any time, should not be used Full Throttle operation of this vehicle.

3,500 1000 km:

To avoid refueling over 3 / 4 throttle position.

4,1000 km long and more:

Full throttle operation should be avoided. Avoid ultra-high-speed engine work.

Note: When traveling to the 300 km 500km, the oil must be replaced.

As the car had not been installed Odometer to estimate mileage can only be calculated

## Parking

When the car to stop, they should stop and pull out the engine ignition key.

Warning:

- because after running and the exhaust muffler very hot, vehicles should be parked in child care and others not likely to encounter places.

## REGULAR MAINTENANCE AND MINOR REPAIRS

Periodic inspection and emphasize peace and lubrication and the car will at the best and most effective work state.

Note: If you are not familiar with this vehicle maintenance services, the work should be COOLSTER maintenance station.

### Regular maintenance / lubrication

Item	Notes	Running-- in1000km or one month	Initial 3000km Or three monthe	Every 3000km Or three monthe
Spark plug	Heck their state. When necessary, should be cleaned or replaced	☆	☆	☆
Air filter	Cleaning. If necessary, should be replaced	☆	☆	☆
Carbutator	Dle checks starting operation. If necessary, should be adjusted	☆	☆	☆
Fuel pipe*	Check whether the fuel for cracks or damage there. If necessary, should be replaced.	☆	☆	☆
Oil filter*	Check the status. If necessary, should be replaced.		☆	☆
Engine oil	The replacement. (In the engine prior to release oil preheating)	300km and 1000km the first replacement	☆	☆
Engine oil filter*	Cleaning. If necessary, adjust or replace	☆		

Item	Notes	Running-- in1000km or one month	Initial 3000km Or three monthe	Every 3000km Or three monthe
Tire/wheel	Check tire pressure / balance / Wear state / poor place, if necessary, repair or replacement		☆	☆
Front hub bearing*	Bearing components check whether loosening / damaged. If damaged, and should be replaced **	☆	☆	☆
Rear axle bearing*	Bearing components check whether loosening / damaged. If damaged, and should be replaced. **		☆	☆
Chain-driven	Check chain relaxation. If necessary, should be adjusted. Cleaning and lubricating	☆	☆	☆
Parts/fastners	Check all the parts and fasteners. Necessary correction should be carried	☆	☆	☆
Battery*	Check proportion. If necessary, the correction should be carried out	☆	☆	☆

\*: We propose that these items should be COOLSTER repair station for maintenance services. \*\*: Medium weight wheel bearing grease.

## Parts / Fasteners

Prior to the use of the car, should always check with the parts and fasteners tight degrees. We suggest that these projects should be carried out irregular inspections. (I asked, after the demolition of the self-locking nut Please replacement of the self-locking nut, as will the use of safety.)

### Correspondence tables fastening torque

Screw size	Fighting torque N•M	Standard torque N•M	Screw size	Fighting torque N•M	Standard torque N•M
M5	4.5- 6.0	5	M10	37-79	60
M6	8-12	9	M12	73-115	99
M8	16-26	23	M14	146-205	180

# Oil

1, the measurement of oil (See left picture)

A. Engine preheater minutes.

B. When the engine stopped operating, hold on a few minutes later, the oil Cypriots will be removed after the oil-observation.

C. The oil should be located at the highest and the lowest among the oil-marker. If the oil level low, should be enough oil to rise to the oil-appropriate.

2, oil and oil filter replacement of the replacement. (See right picture)

A. Engine preheater minutes.

B. engine will stop. In an engine oil was placed underneath.

C. discard release oil bolts, release oil. Put oil may moderate shaking body to be inside the engine from impurities.

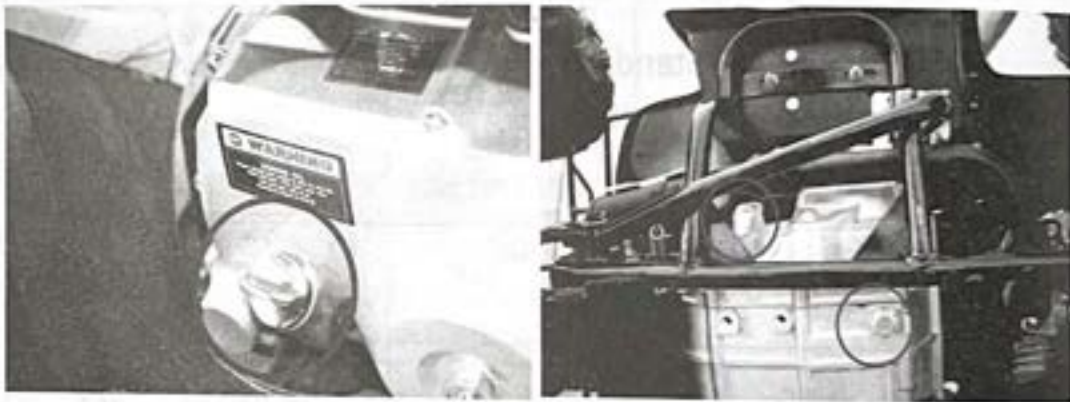

D. installed release oil bolts, and then full of engine oil. Tightening oil Cypriots.

1. Starting engine and a few minutes to preheat. Preheat should check whether there are oil spills. If it appears that an oil spill, should immediately stop engine and check reasons.

3, the replacement of oil in the second about a month or so to clean oil filters

Warning:

- Do not join any chemical additives. Also lubricating oil clutch, clutch slipping and additives will.

Note: In the replacement of oil, must be in accordance with the following method to check oil pressure.

- 1, removed the cylinder covered with oil release bolts.
- 2, starter motors, and keep them idle until the oil outflow from caving hole. If no one minute after the oil outflow or unusual phenomenon, should stop the engine running to the nearest COOLSTER dealer or repair shop for repair.
- 3, after the test should be tightened release oil bolts.

## Carburetor adjustment

Carburetor is a key part of the car, the need for fine adjustment. Most adjustments should be entrusted with the expertise and experience COOLSTER dealers or repair shops.

### Idle adjustment

Screw idling



Release oil point



1. Connect speed
2. Speed Festival through idle screw on the carburetor, idling provisions set to rotate within the raise into the engine speed, to a decrease in engine speed from

Standard Idle:

1500 ± 150 to / min

## Crankcase emission filter of the circulatory system

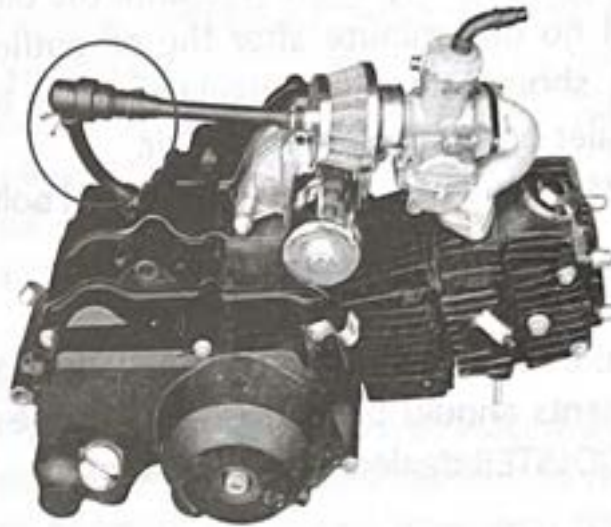

- 1、 the part works for 150 hours, please cleaning to make the part to use normally.
- 2、 take out filter of oil and gas separator, using gasoline or kerosene to carry out the washing, and drying.
- 3、 in the filter out, remember not to damage the filter.
- 4、 the part may clean and use repeatedly in the non-damage's situation.
- 5、 the part in use, will be regularly open sewage outfall for discharge, the user can also be observed at any time, please discharge the squalidity in accordance with the actual situation.

## Air Filters

Filters should carry out regular checks, cleaning. If necessary, replaced.

## The throttle cable adjustment

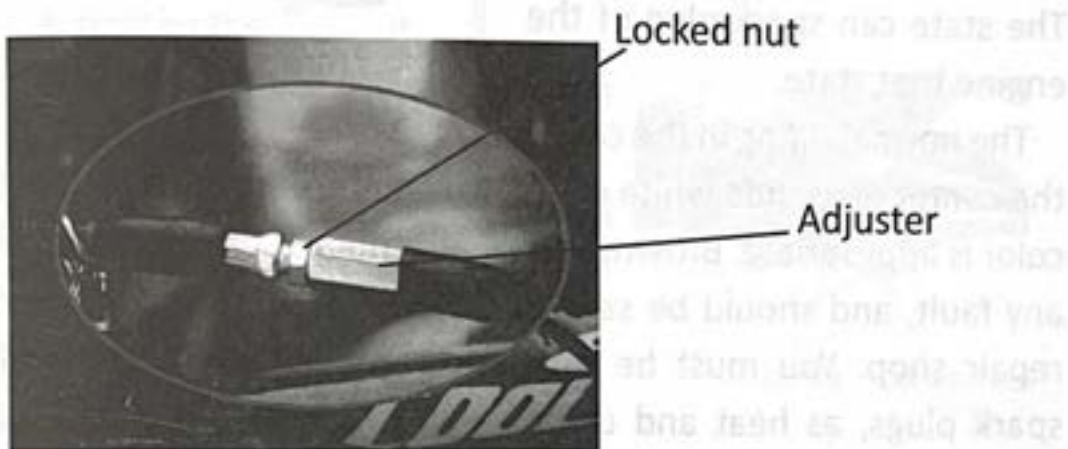

**Note:** In adjusting the throttle cable free trip before, we must adjust engine idling.

Through rotational regulator to adjust throttle cable, it can lead to throttle the right hand free Filed doors itinerary.

Free trip:

3 to 7 mm

1, loosen lock nut.

2, Hin into a regulator or until attaining the free trip.



# Spark Plug inspection

Model: D7TC

Clearance: 0.6~0.7 mm

Torque: 12.5 N • M

The spark plug is an important engine parts, and easy to check. The state can spark plug of the engine that state.



0.6~0.7mm

The normal riding in the car, in the center electrode white ceramic insulators around the ideal color is appropriate. Brown. Do not attempt to self-diagnosis of any fault, and should be sent to COOLSTER the car dealer or repair shop. You must be regularly removed and examined spark plugs, as heat and carbon deposition will spark plugs slowly breakdown and ablation. If the electrode ablation too seriously, we must use the provisions of its spark plugs will be replaced.

Before installing the spark plug, the regulation should be used to measure the thickness electrode gap, if necessary, will be adjusted to space requirements value.

Note: If you have not installed when the spark plug torque wrench, torque correct estimation method is tightening its hand to exceed 1 / 4 to 1 / 2 laps

## The front wheel brake adjustment

The front wheel brake handle free trip for 10 - 15 mm

- 1, loosen lock nut
- 2, rotation cable length regulator, screw or screw into the appropriate date and up.
- 3, tighten the lock nut.

When the brake handle and can not be used to appropriate requests, please COOLSTER commissioned by the dealer or repair shop to adjust brake shoes.

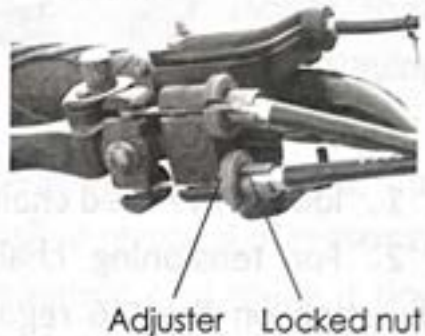
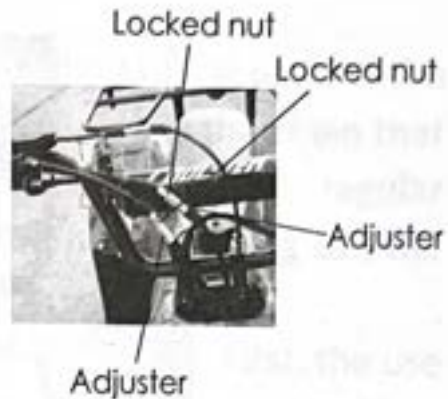

## Driving chain relaxation of inspection

Note: rotating wheel several times to identify the most compact location of the chain. When the chain in the most compact position, check or adjust chain relaxation.

The normal relaxation of 10 to 20 mm. If relaxation beyond 20 mm should be adjusted.



## The drive chain adjustment

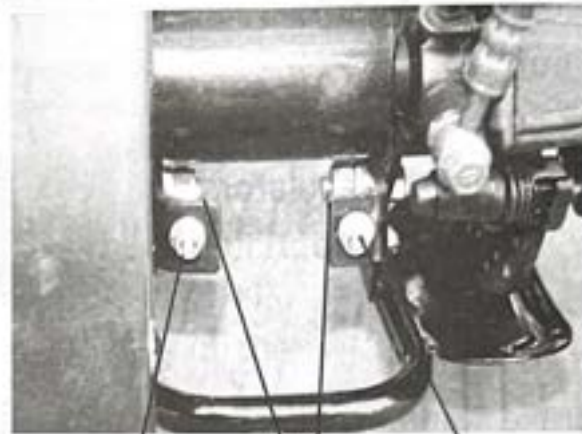

Ad juster    Setscrew    Ad juster

- 1、 loosen the fixed chain adjuster screw and nut.
- 2、 For tensioning chain, the chain by rotating clockwise direction on the M6 regulator anti-retreat-pine nut and nut. If required relax chain, according to the direction of rotation 10,000 anti-chain adjuster on the M6 and the prevention of anti-retreat Pine Nut Nut.

Forward and rear axle into. The same should be fully rotate the regulator of the M6 and the prevention of anti-retreat Pine Nut Nut, Pian would maintain coaxial.

- 3、 in the adjustment, must tighten all loosen the parts.
- 4、 in the adjustment, the chain must tighten regulation of the fixed screws and nuts.

Note: chain relaxation too small engines and other key will zero overloading. Relaxation should be made to maintain the prescribed limit scope.

# The drive chain lubrication

The chain includes many mutual operation of the parts. If the chain would not carry out proper maintenance, the chain that will soon wear. Therefore, we must carry out regular maintenance of the chain. In this dusty region riding car, the more maintenance is necessary.

1, may use any brands of spray-chain lubricant. First, the use of brush or cloth to remove all the dirt and mud masonry. Then two rows of siding between the center and all spraying lubricant on the roller.

2, For cleaning chain, will be removed from the board, the Baptist in solution should as far as possible removal of masonry scale. The chain removed from the solution and make it dry. The chain lubrication will be carried out immediately to prevent corrosion.

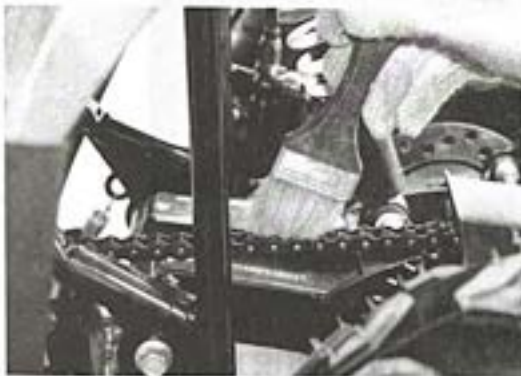

## Throttle limited & parking function

Please use parking button when you are parking, see picture.

- 1、Fasten front brake
- 2、Press parking button

Left picture throttle limited nut .

- (1)adjust screw
- (2)lock nut
- (3)parking button

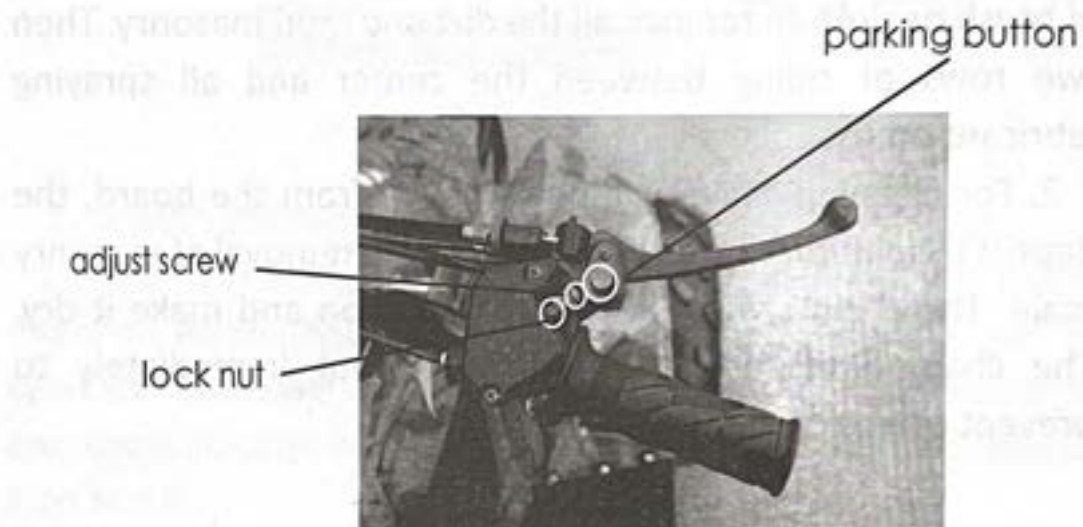

## Battery

Check the batteries battery electrolyte level, and recognizing the terminal and the wiring of the battery casing is not leakage. If the electrolyte level low, add distilled water.

Note: The battery electrolyte checks at least once a month.

Warning:

- use batteries to be recharged in 30 minutes and cooled to room temperature to ensure the proper use of batteries. Battery electrolyte toxic and therefore dangerous, and so will cause serious burns. The electrolyte contains sulfuric acid. Avoid contact with skin, eyes or clothing.

- battery would have exploded gas. Should stay away from sparks, flames, cigarettes, and so on, in or rechargeable battery sealed in a space, ventilation should be maintained. Near the battery should always work to protect your eyes.

- should be placed in child care could not get places



## The replacement fuse

- 1, fuse at the top of batteries.
- 2, if the fuse fuse, customs breakpoint fire Switches and circuit switching problem. With the correct installation of the new ampere fuse. Connect the switch and watch the work of electrical installations. Fusing immediately if the fuse again, please COOLSTER dealer or repair shop contact.

### Warning:

- Do not use the recommended ampere rating higher than the fuse. Under the correct rating is the fuse will cause large-scale damage to electrical system and will cause the fire.

Provides fuse: 10 amps

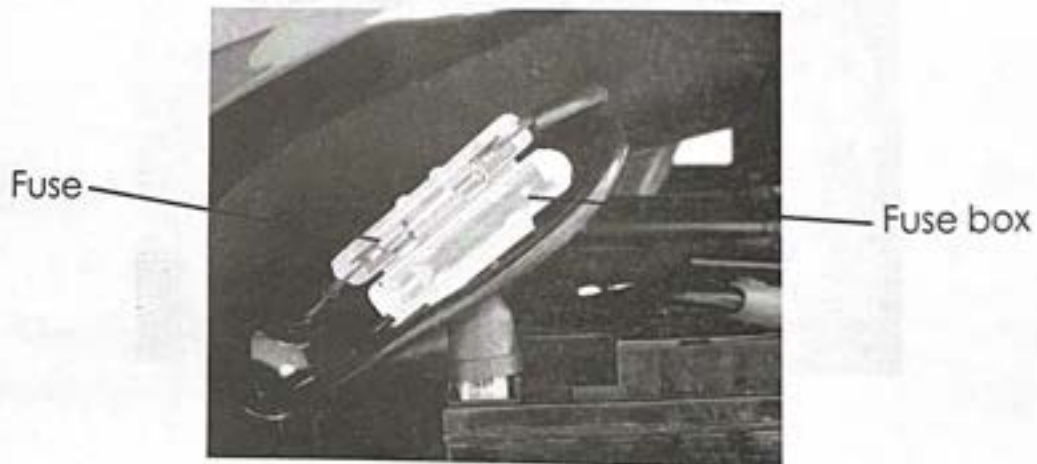

# Common problem

problem instance	reason	Solve way	
Hard start or could start	1.no mixed gas in cylinder	①leaking for intake system	Screw down on sealed point
		②oil way plugged up	scatter
	2.heap fuel in cylinder		Open spark plug, clean fuel
	3.fuel has water or dirty		Clean fuel tank, carburetor, change fuel
	4.cylinder compression low	①spark plug leaking	Screw down spark plug
		②leaking on the sealed point between cylinder cover and cylinder body	Clean it, install gaskets,screw down nut
		③crankcase leaking	Renew crankcase or sealed glue of crankcase
		④piston ring or cylinder body wear and tear heavy	Renew piston ring or cylinder body
		⑤piston ring broke off or block	Renew piston ring or clean it
	5.exhaust block	Exhaust of cylinder or vent-pipe is dirty	Clean it
6.mixed gas is thick or thin		Adjust carburator	



Hard start or could start	7.spark plug problem	①spark plug is dirty	Clean it with gas
		②insulator of spark plug broke	Renew spark plug
		③space of spark plug is too big or small	Renew or adjust
	8.magneto problem	①low-pressure wire is short circuit or turnoff	Find it , repair or renew
		②ignition broke	renew
		③ignition coil	renew
	9.no enough battery(hard start)		Remove and
	10.foot start could work		Repair or renew
	11.E-start	Rotor of E starter couldn' t work	renew
	12.other device couldn' t work		Check and repair

Engine is instability	1.ignition touch is not good		Connect again
	2.electrode of spark plug is dirty		Clean it
	3.all circuits block up		scatter
	4.clutch skid		Repair or renew
	5. mixed gas is thick or thin		Adjust carburator
	6.engine oil is not enough		Add engine oil
	7.vent-pipe block up		clean

problem instance	reason	Solve way
Engine couldn't work	1.fuel couldn't feed(circuit block up)	Check oil switch, carburetor etc, repair it
	2.break off	Check wire from spark plug to magneto
	3.cylinder broken heavy, piston dead	Repair or renew
	4.join bearing dead	Repair or renew
	5.other device couldn't work	Check them ,repair or renew
Engine power is not enough	1.circuit block up	scatter
	2.ignition time is fast or slow	adjust
	3.spark is weak	Check it from spark plug to magneto
	4.mixed gas is thick or thin	Adjust carburator
	5.engine leaking	Check ,repair
	6.vent-pipe block up	scatter

Bike is shaking heavy	1.spring of suspension break off	renew
	2.suspension bend	renew
	3.suspention leaking	renew
	4.bearing of wheel broke	renew
Running direction is unstability	1. parts of director handle it tight or loose	Check them
	2.tire press is not enough	Check them
	3.frame, suspension install is improper	Install again and adjust
	4. axes is easy to move	adjust
Brake couldn't work	1.shoes of rear brake wear and tear heavy	renew
	2.brake cam wear and tear	renew
	3.front, rear brake pull cable broke	renew
	4.space of front, rear wheel is too much	renew

# CLEANING

1, in order to keep the car clean and protect the surface appearance of the painting, electroplating, should regularly or irregularly its cleansing. When cleaning, use of external surface water irrigation, rush soil. Use a soft cloth or sponge dip cleaning liquid bubble gently cleans the outer surface, to avoid residual gravel surface and paint scratches electroplating layer. Finally reuse water for irrigation.

2, attention:

- washing, to avoid using the high-pressure water erosion under parts:

- (1) ignition switch;
- (2) multi-purpose switch;
- (3) Below cushion;
- (4) The exhaust pipe muffler exports;
- (5) air filter inlet

After the car wash thoroughly dry, and then start engine, running for a few minutes. Finally repeatedly braking performance brake inspection and adjustment until braking performance standards so far.

Special Note: in the hot engine, the first will not wash. Engine room temperature with the same question again when cleaning. If water pressure caused the brake, the former damping seals and electrical parts Loss

## STORAGE

If the park does not need to use a long time, in order to maintain a good state of the car, you please address the following methods:

1), select the right parking place. The location should have security, ventilation, moisture-proof, anti-freezing conditions.

2), for engine lubricants.

3) in the fuel tank and the carburetor fuel release all net, oil stored properly. Note: Do not overlook the release carburetor net residual oil. Otherwise, no need for a long time, the surface of the plastic fuel carburetor of holes to plug, re-use of the car when trouble.

Warning: volatile fuel in the fuel emissions, the engine must be stopped operating in the ventilation good place to prohibit smoking ban on the use of open flame and sparks objects.

4) In order to prevent cylinder rust, we should adopt the following measures:

Remove spark plugs, A Spoonful (15 ~ 20 m) from the clean engine oil into the cylinder spark plug hole with a piece of cloth spark plug holes starter motors, mobile number to Detroit from top to bottom so that the oil in the cylinder wall are cloth. Finally, the spark plugs and spark plug cap installed.

5) Battery demolition down, stored in antifreeze, sunscreen, and other items collision difficult places. Every two weeks an additional charge.

6) wash and dry your car, paint waxing to all, to all chrome painted on the surface antirust oil.

7) to inflatable tires, tire pressure up to the required standard air pressure. After stopping the car will be good, with shelves or pieces of wood and other wheels will be boosted so that the wheel does not contact with the ground.

8) will cover the car to prevent the dust down. Do not use plastic sheeting to things such as gas-tight coverage, as there are for the mechanical vapor corrosion.

## **Transport**

1. Vehicles should be solidly fixed on the transporters, there should be effective rain preventing measures, without bumps and damaged phenomenon happen.

2. The packing carton shall not be tilted on the way of delivery.

## **AFTER THE RE-USE STORAGE**

1) Remove the guards cover the car, clean the body. If placed more than four months, the need for replacement of engine oil.

2), the battery will be sufficient to re-installed on board.

3) add fuel to the fuel tank.

4) all of the pre-inspection lane.

5) before traveling during the next regular session, a choice open, pedestrian areas for less performance inspection, confirmed Properties normal traffic could resume normal.

# ATV-3050C INSTALL PROCESS AFTER UNPACKING(1)



Disassembled packaging belt



Take out carton



Disassembled metal frame



Disassembled metal frame



Pick parts out



Install front protector

## ATV-3050C INSTALL PROCESS AFTER UNPACKING(2)



Install rear rack



Install handle bar



Install front wheel



Remove rear axle fasten



Install rear wheel



Install dust cap



# ATV-3050C INSTALL PROCESS AFTER UNPACKING(3)



Fill liquid of battery



Install seal of battery



Install battery & link wire



Install seat



## ATV-3050C INSTALL PROCESS AFTER PACKAGING(4)

### Correspondence tables fastening torque

Screw size	Tightening torque N•M	Standard torque N•M
M5	4.5-6.0	5
M6	8-12	9
M8	16-26	23
M10	37-79	60
M12	73-115	99
M14	146-205	180

# Emission Warranty Statement.

## U.S.A. EPA Emissions Limited Warranty

This All Terrain Vehicle (ATV) and Off Highway Motorcycle (OFMC) emissions limited warranty is in addition to the Maxtrade standard limited warranty for All Terrain Vehicles.

Maxtrade warrants that this vehicle are; (1) designed, built, and equipped to conform at the time of initial sale with the requirements of 40 CFR 1051 and, (2) free from defects in materials and workmanship that may keep it from meeting these requirements.

The emissions warranty period for this vehicle begins on the date the vehicle is delivered to the original retail purchaser, vehicles with displacement of 100cc and over, warranty period shall be 5 years or 5,000 km, whichever comes first. On vehicles with displacement of 100cc and under warranty period shall be 5 years or 10,000 km whichever comes first.

This emission - related warranty covers components whose failure would increase an engine's emissions, including electronic controls, fuel injection, exhaust—gas reticulation, after treatment, or any other system utilized in this vehicle to control emissions. Replacing or repairing other components not covered by this emissions warranty or the standard warranty is the responsibility of the owner; including the parts, labor and other costs associated with recommended maintenance.

The exclusive remedy for breach of this limited warranty shall be, at the exclusive option of Maxtrade, repair or replacement of any defective materials, components or products. THE REMEDIES SET FORTH IN THIS LIMITED WARRANTY ARE THE ONLY REMEDIES AVAILABLE TO ANY PERSON FOR BREACH OF THIS WARRANTY. MAXTRADE SHALL HAVE NO LIABILITY TO ANY PERSON FOR INCIDENTAL, CONSEQUENTIAL OR SPECIAL DAMAGES OF ANY DESCRIPTION, WHETHER ARISING OUT OF EXPRESS OR IMPLIED WARRANTY OR ANY OTHER CONTRACT, NEGLIGENCE OR OTHER TORT OR OTHER WISE.

ALL IMPLIED WARRANTIES (INCLUDING BUT NOT LIMITED TO ANY IMPLIED WARRANTIES OF MERCHANTABILITY AND FITNESS FOR A PARTICULAR PURPOSE) ARE LIMITED IN DURATION TO THE WARRANTY PERIOD DESCRIBED HEREIN. MAXTRADE DISCLAIMS ALL EXPRESS WARRANTIES NOT STATED IN THIS WARRANTY. Some states do not allow limitations on how long an implied warranty lasts, so the above limitation may not apply if it is inconsistent with the controlling state law.

This limited warranty excludes failures not caused by a defect in material or workmanship. This limited warranty does not cover damage due to accidents, abuse or improper handling, maintenance or use. This limited warranty also does not cover any engine that has been structurally altered, or any engine that has been used in racing competition. This limited warranty also does not cover physical damage, corrosion or defects caused by fire, explosions to other similar causes beyond the control of Maxtrade.

If you have any questions regarding your warranty rights and responsibilities, you should contact the Maxtrade Warranty Department at 1-626-228-0251

## EMISSIONS WARRANTY PARTS LIST

<u>Fuel Metering System</u>	<u>Ignition System</u>	<u>Exhaust System</u>	<u>Emission Control System</u>
Carburetor	Spark Plug	Exhaust Manifold	Air Cleaner Housing
	CDI	Ignition Coil	Air Cleaner Housing Cov.

Model Year: 2018 or Later Models

Manufacture Name: Zhejiang Qiye Scooter Co., LTD

Importer Name: Maxtrade LLC.

### Emission-Related Part Number #

ENGINE FAMILY	CARBURETOR	INTAKE MANIFOLD	SPARK PLUG	EXHAUST MANIFOLD	AIR CLEANER HOUSING COVER	CDI	IGNITION COIL
KMXTX.120M1A LMXTX.120M1A MMXTX.120M1A NMXTX.120M1A PMXTX.120M1A	QIYE 11	QIYE 12	A7TC	QIYE 13	E4.GH110-1	QIYE 2	QIYE 4
JMXTX.125M4A KMXTX.125M4A LMXTX.125M4A MMXTX.125M4A NMXTX.125M4A PMXTX.125M4A	QIYE 11A	QIYE 12	A7TC	QIYE 13	E4.GH110-1	QIYE 2	QIYE 4
KMXTX.150M5A LMXTX.150M5A MMXTX.150M5A NMXTX.150M5A PMXTX.150M5A	QIYE 31	QIYE 32	A7TC	QIYE 33	QIYE 35	QIYE 3	QIYE 8
JMXTX.125M8A KMXTX.125M8A LMXTX.125M8A MMXTX.125M8A NMXTX.125M8A PMXTX.125M8A	QIYE 25	QIYE 12	A7TC	QIYE 13	E4.GH110-1	QIYE 2	QIYE 4
JMXTX.072M7A KMXTX.072M7A LMXTX.072M7A MMXTX.072M7A NMXTX.072M7A PMXTX.072M7A	QIYE 41	QIYE 42	A7TC	QIYE 43	E4.GH110-1	QIYE 2	QIYE 5
JMXTX.170M5A KMXTX.170M5A LMXTX.170M5A MMXTX.170M5A NMXTX.170M5A PMXTX.170M5A	QIYE 31	QIYE 32	A7TC	QIYE 33	QIYE 35	QIYE 3	QIYE 8

# ATV-3050C Main specs (1)

## 1,The main specs of size

1.1 Model dimensions.....	1250×900×940(L•W•H)
1.2 Wheel base	
a)wheel base front.....	735mm
b)wheel base rear.....	590mm
1.3 Wheel base.....	790mm
1.4 Seat height.....	650mm
1.5 Ground clearance.....	105mm
1.6 Minimum turning radius.....	1850±500mm
1.7 Steering angle.....	left\ light 32°±5°

## 2,The main quality specs

2.1 N.W.....	80kg
2.2 G.W.....	90kg
2.3 Max load.....	65kg

## 3,Engine specs

3.1 Engine no.....	1P47FMH(70cc)/1P47FMF(90cc) 1P52FMD(110cc)
3.2 Engine type.....	4-stroke, single cylinder
3.3 Cylinder work vol .....	70CC/90CC/110CC
3.4 Compression ratio.....	9:1 / 8.8:1 / 9:1
3.5 Max power .....	3.4/7500±500 4.0/7500±5500 4.36/7500±500 Kw/r/min
3.6 Max torque .....	5.7/5500±500 6.0/5500±500
3.7 The mirli speed unloads tability.....	6.18/5500±500 N•n/r/min 1500150r/min
3.8 Gas type.....	≥90#
3.9 Lubricant type.....	SF 15W/40
3.10 Crankcase lubricants capacity .....	900ml
3.11 Lubrication system.....	pressure spatter
3.12 Starting system.....	electric
3.13 Lgnition.....	CDI
3.14 Clutch type.....	Auto clutch
3.15 Transmission.....	chain

## ATV-3050C Main specs (2)

3.16 Carburator no.....	PZ20
3.17 Carburator type.....	Plunger
3.18 Spak plug no.....	D7TC
3.19 Spark plug space.....	0.6-0.7
3.20 Vent-pipe type.....	buffer
3.21 Bore X Stroke.....	47X41.5(70CC) 47x49.5(90CC) 52.4X49.5(110CC)
3.22 Fuel tank capacity.....	2.4
4,Operating system	
4.1 Suspension system	
a)suspension front.....	traverse double-arm
b)suspension rear.....	non-independent suspension
4.2 Shock absorber type	
a)shock absorber front.....	hydraulic spring
b)shock absorber rear.....	hydraulic spring
4.3 Tire specs pressure	
a)tires front.....	145/70-6=10~24psi
b)tires rear.....	16X8-7=10~24psi (pressure) 145/70-6=10~24psi
5,Brakes system	
a)barkes front.....	Mechanical hub brake/hand manipulating patterns
b)brakes rear.....	Hydraulic disc/foot manipulating patterns
6,Electrical Equipment	
6.1 Front light.....	12V35/35W
6.2 Generator.....	non-contact outside the rotor flywheel
6.3 Battery.....	12V4AH / 12V5AH
6.4 Rear light.....	12V21/5W

## Spark Arrestor Screen (Maintenance)

Required maintenance and cleanout:

1. After every 100 hours of operation the muffler should be cleaned by removing the clean out bolt by using a 6.0mm Allen wrench.

2. After every 60 hours of operation the Spark Arrester has to be cleaned by loosening the retaining nut using a 6.0mm Allen wrench. Using pliers turn the sleeve of the Spark Arrester counterclockwise and pull out. Clean the screen with an exhaust cleaning solution and replace, securing it by tightening the retaining nut.

3. After every 200 hours of operation the Spark Arrester has to be replaced by loosening the retaining nut using a 6.0mm Allen wrench. Using pliers turn the sleeve of the Spark Arrester counterclockwise and pull out. Replace a new Spark Arrester and secure it by tightening the retaining nut.

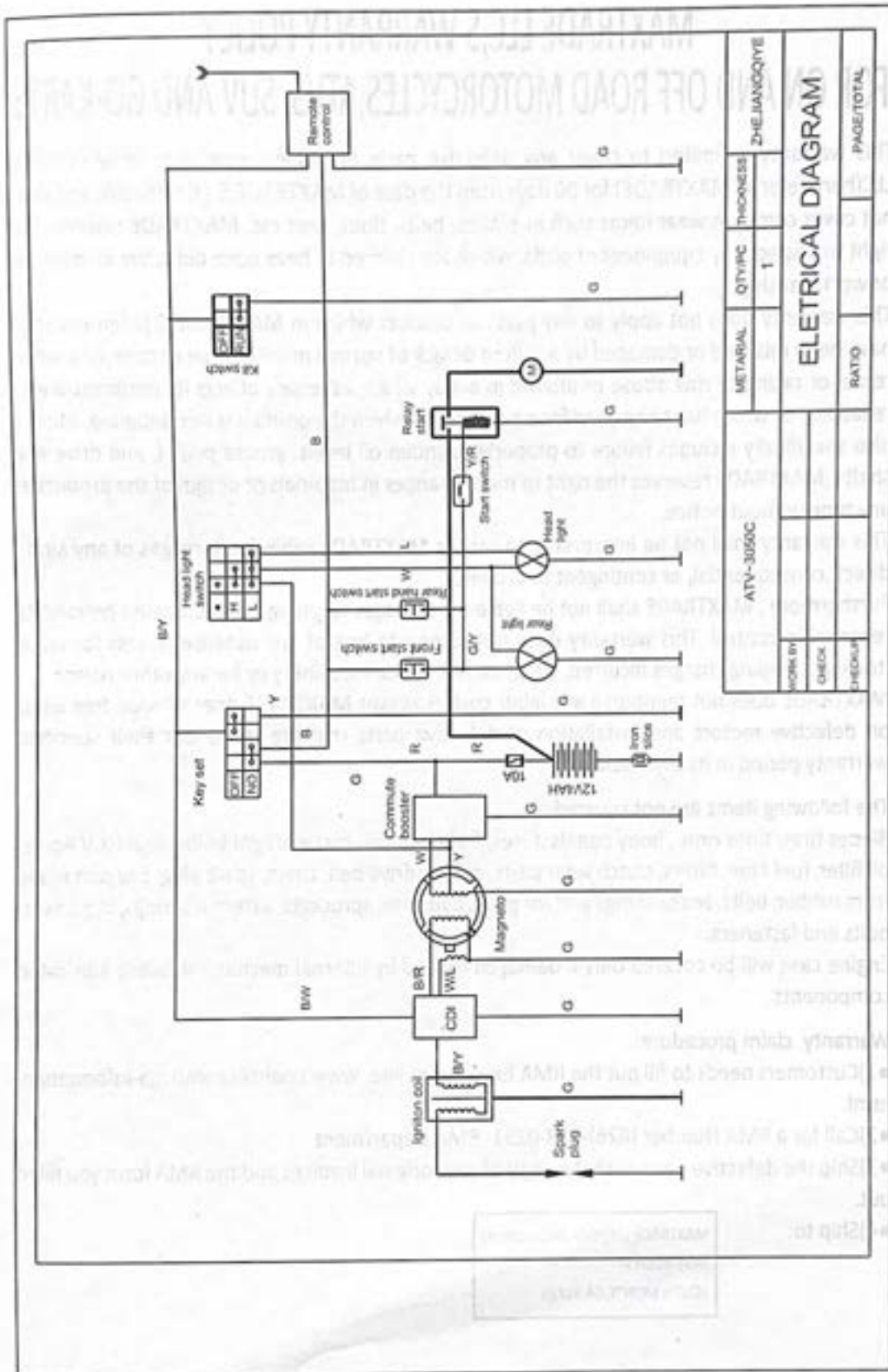



# MAXTRADE LLC,S WARRANTY POLICY FOR ON AND OFF ROAD MOTORCYCLES,ATVS, SUV AND GO-KARTS

This warranty is limited to cover any defective parts of original purchaser of MAXTRADE LLC(here refer as MAXTRADE) for 90 days from the date of MAXTRADE,S sales invoice and does not cover common wear items such as blades, belts, tines, tires etc, MAXTRADE reserves the right to inspect any equipment or parts, which are claimed to have been defective in ,material or workmanship.

This warranty does not apply to any parts or product which in MAXTRADE,S judgment shall have been misused or damaged by accident or lack of normal maintenance or care ,or used as rental or racing or ride abuse or altered in a way which adversely affects its performance or reliability, or which has been used for a purpose for which the product is not designed, Misuse also specifically includes failure to properly maintain oil levels, grease points, and drive line shafts ,MAXTRADE reserves the right to make changes in materials or design of the product at any time without notice,

This warranty shall not be interpreted to render MAXTRADE liable for damages of any kind , direct ,consequential, or contingent to property,

Furthermore , MAXTRADE shall not be liable for damages resulting from any cause beyond its reasonable control ,This warranty does not extend to loss of any expense or loss for labor ,towing ,shipping charges incurred, supplies, and rental machinery or for any other reason.

MAXTRADE does not reimburse any labor cost, However MAXTRADE does provide free labor on defective motors and installation of defective parts that are still under their specified warranty period in its own facility.

#### The following items are not covered:

Blades tires, tines rims , body panels ,fuses, forks ,shocks, gaskets, light bulbs, seats ,CV Boots, oil filter, fuel filter, filters, clutch wear parts, cables, drive belt, chain, spark plug, any part made from rubber, belts, brake linings and /or pads, batteries, sprockets, external springs, clips, nuts, bolts and fasteners.

Engine case will be covered only if damaged caused by internal mechanical failure lubricated components.

#### Warranty claim procedure:

- 1)Customers needs to fill out the RMA form. From line: [www.coolster.com/rma-information.html](http://www.coolster.com/rma-information.html).
- 2)Call for a RMA Number (626)-228-0251- RMA Department
- 3)Ship the defective parts with the copy of your original invoices and the RMA form you filled out.
- 4)Ship to:

MAXTRADE LLC(RMA Department) 9436 RUSH ST SOUTH MONTE,CA 91733
--

●5)After receiving the parts ,MAXTRADE will be do an inspection and other necessary steps to repair, rebuild or replace warranty part and send them back to customer.

### **WHY WE NEED YOU TO SEND PARTS BACK?**

- We need to verify your replacement part is the correct one to send you.
- We require the part back so we may monitor defective parts and notify the correct manufacture of potential future problems or recalls.
- We need to verify that your part in fact defective ,Many times receive parts that are not defective at all.

### **SHIPPING AND HANDLING CHARGES:(S/H CARGES)**

Within in warranty period customer pays S/H charge to MAXTRADE facility and MAXTRAD will pay return shipping to customer unless it is determined the part was abused, misused or damaged in any way other, than a manufacturers defect, Customer needs to pay for part(s) and S/H both ways for out of warranty parts.

### **All Sales Policy:**

All sales are final, No return, no exchange ,No refund for any reason.

### **Changes ,Errors /Inaccuracies:**

www.coolster.com reserves the right to update or modify these Terms/ Conditions at any time without prior notice ,improvements to products may result in unannounced small changes to specifications and external appearance, We strive to list and advertise all text and product information as accurate as possible ,However ,unforeseen, typographical errors ,picture errors and inaccurate information on this website may occur, We reserve the right to correct any errors ,inaccuracies or omissions and to change or update information at any time without prior notice, including order that have already been submitted ,if such errors occur ,we apologize for any inconvenience.

### **Binding Agreement:**

These Terms and Conditions, together with all Exhibits to these Terms and Conditions form a binding agreement( the .Agreement) between the buyers and Maxtrade LLC.



## WARNING

Improper ATV use can result in SEVERE INJURY or DEATH.



ALWAYS USE  
AN APPROVED  
HELMET AND  
PROTECTIVE  
GEAR



NEVER USE  
ON PUBLIC  
ROADS



NEVER CARRY  
PASSENGERS



NEVER USE  
WITH DRUGS  
OR ALCOHOL

**NEVER Operate:**

- without proper training or instruction.
- at speeds too fast for your skills or the conditions.
- on public roads-a collision can occur with another vehicle.
- with a passenger-passengers affect balance and steering and increase risk of losing control.

**ALWAYS:**

- use proper riding techniques to avoid vehicle overturns on hills and rough terrain and in turns.
- avoid paved surfaces-pavement may seriously affect handling and control.

LOCATE AND READ OWNER'S MANUAL.  
FOLLOW ALL INSTRUCTIONS AND WARNINGS.



To buy parts online please go to :  
[www.coolster.com/catalog](http://www.coolster.com/catalog)  
[www.coolster.com](http://www.coolster.com)