

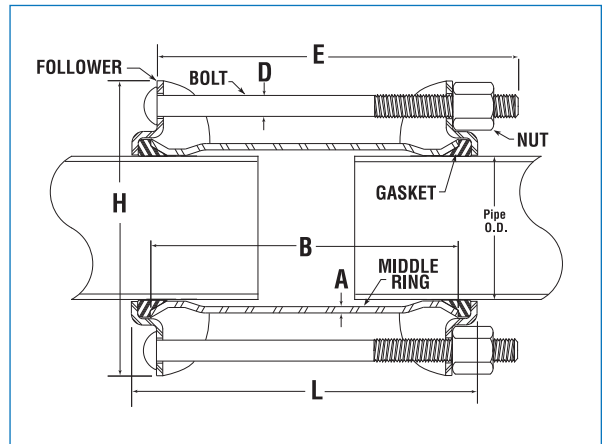

For widely separated pipe ends

Style 40 Long Body Couplings

Dresser Style 40 Long Body Couplings provide a simple and effective method of joining pipe when gaps in pipe ends are wider than ordinary. Style 40 couplings are similar in construction to Style 38 couplings except that middle rings are longer and have a larger belly diameter. Though longer, they absorb the same amount of expansion and contraction as the Style 38 coupling, up to 3/8" per joint.



Materials of Construction

Followers: AISI C1012 or ASME SA36 (Ductile Iron or Malleable Iron for 1/2" thru 1-1/2")

Middle Ring: ASTM A513, ASTM A635 or ASME SA675 GR60

Bolts: AWWA C 111/ANSI A21.11

Gaskets: Grade 27 BUNA S

Coating: Fusion-Bonded Epoxy

PRESSURE RATINGS NOTE: Consult factory for pressure ratings that represent your particular product requirements

Style 40 Long Couplings

Specifications for Cast-Iron Pipe Sizes 2" thru 24"

Pipe Nominal Size (In)	Outside Pipe Diameter (OD)	Middle Ring Thickness & Length ¹ (A&B)	Bolts ² No./Diam. x Length (D&E)	Overall Dimensions		Working Pressure Lbs. per Sq. In.	Max. Test Pressure Lbs. per Sq. In.	Approx. Shipping Weight (Lbs.)
				Diam. (H)	Length ³ (L)			
2	2.500	.180 x 12	3-5/8 x 15	6-1/2	17	1302	1953	17
2	2.625	.180 x 12	2-5/8 x 15	6-1/4	17-3/8	1302	1953	18
2	2.750	.180 x 12	3-5/8 x 15	7	17	1302	1953	20
3	3.74 - 4.02	.188 x 12	4-5/8 x 15	7-3/4	17	939	1408	24
4	4.74 - 5.06	.229 x 12	4-5/8 x 15	9	17	250	375	29
6	6.84 - 7.16	1/4 x 16	6-5/8 x 19-1/2	11	21	945	1417	63
8	8.99 - 9.36	1/4 x 16	6-5/8 x 19-1/2	13-1/16	21	743	1114	80
10	11.04 - 11.76	3/8 x 16	8-5/8 x 19-1/2	15-13/16	21-3/4	908	1362	112
12	13.14 - 13.56	3/8 x 16	8-5/8 x 19-1/2	18-1/16	21-3/4	776	1164	135
14	15.300	3/8 x 16	10-5/8 x 19-1/2	18-1/16	21-3/4	675	1012	155
14	15.650	3/8 x 16	10-5/8 x 19-1/2	18-1/16	21-3/4	661	991	164
16	17.400	3/8 x 16	10-5/8 x 19-1/2	18-1/16	21-3/4	600	900	167
16	17.800	3/8 x 16	10-5/8 x 19-1/2	18-1/16	21-3/4	587	880	173
18	19.500	3/8 x 16	12-5/8 x 19-1/2	18-1/16	21-3/4	539	808	203
18	19.920	3/8 x 16	12-5/8 x 19-1/2	18-1/16	21-3/4	529	793	204
18	19.920	3/8 x 24	12-5/8 x 28	18-1/16	29	529	703	269
20	21.600	3/8 x 16	12-5/8 x 19-1/2	18-1/16	21-3/4	490	735	226
20	22.060	3/8 x 16	14-5/8 x 20	18-1/16	22-3/4	480	720	227
24	25.800	3/8 x 16	15-5/8 x 20	18-1/16	22-3/4	414	621	258
24	26.320	3/8 x 24	15-5/8 x 20	18-1/16	22-3/4	406	609	265

1- Middle Rings - Thicker or longer than those listed can be furnished.

2- Bolts - Furnished E-coated steel as standard.

3- Dimension "L" - Overall length taken with fasteners drawn up finger tight.

NOTE: Special and larger sizes are available and special length bodies can be supplied.

Style 40 Long Couplings

Specifications for Steel Pipe Sizes 1/2" thru 24"

Pipe Nominal Size (In)	Outside Pipe Diameter (OD)	Middle Ring Thickness & Length ¹ (A&B)	Bolts ² No./Diam. x Length (D&E)	Overall Dimensions		Working Pressure ⁵ Lbs. per Sq.In.	Max. Test Pressure Lbs. per Sq.In.	Approx. Shipping Weight (Lbs.)
				Diam. (H)	Length ⁴ (L)			
1/2	.840	.156 x 12	2-1/2 x 14	3-1/2	15-5/8	1500	2250	4-1/2
3/4	1.050	.156 x 12	2-1/2 x 14	3-13/16	15-5/8	1500	2250	5
1	1.315	.148 x 12	2-1/2 x 14	4-1/16	15-5/8	1500	2250	6
1-1/4	1.660	.154 x 12	2-1/2 x 14	4-7/16	15-5/8	1500	2250	6-1/2
1-1/2	1.900	.165 x 12	2-1/2 x 14	4-3/4	15-5/8	1500	2250	7-1/2
2	2.375	.156 x 12	3-1/2 x 15	6-1/4	17	1500	2250	15
2	2.375	.156 x 24	3-1/2 x 28	6-1/4	29	1500	2250	33
2-1/2	2.875	.180 x 12	3-5/8 x 15	7	17	1500	2250	12
2-1/2	2.875	.180 x 24	3-5/8 x 28	7	29	1500	2250	20-1/2
3	3.500	.156 x 12	4-5/8 x 12-3/4	8	15	1500	2250	23
3	3.500	.156 x 24	4-5/8 x 28	8	29	1500	2250	40
3-1/2	4.000	.188 x 12	4-5/8 x 12-3/4	8-5/8	15	1175	1763	25
4	4.500	.188 x 12	4-5/8 x 12-3/4	9	15	1063	1595	28
4	4.500	.188 x 24	4-5/8 x 28	9	29	1063	1595	44
4-1/2	5.000	.229 x 12	4-5/8 x 12-3/4	9	15	930	1395	30
5	5.500	.280 x 16	4-5/8 x 19-1/2	9	21	1162	1743	41
5	5.563	.280 x 16	4-5/8 x 19-1/2	10-3/8	21	1162	1743	51
5-5/8	6.000	.280 x 16	6-5/8 x 19-1/2	10-3/8	21	935	1403	66
6	6.625	1/4 x 16	6-5/8 x 19-1/2	11-1/4	21	968	1452	54
6	6.625	1/4 x 24	6-5/8 x 28	11-1/4	29	968	1452	60
6-5/8	7.000	1/4 x 16	6-5/8 x 19-1/2	11-3/4	21	923	1385	54
7-5/8	8.000	1/4 x 16	6-5/8 x 19-1/2	13-1/4	21	822	1233	60
8	8.625	1/4 x 16	6-5/8 x 19-1/2	13-1/4	21	769	1154	63
8	8.625	1/4 x 24	6-5/8 x 28	13-7/8	29	769	1154	85
9-5/8	10.000	1/4 x 16	8-5/8 x 19-1/2	13-7/8	21	674	1011	75
10	10.750	1/4 x 24	8-5/8 x 28	14-5/8	29	632	948	81
10	10.750	1/4 x 16	8-5/8 x 19-1/2	14-5/8	21	632	948	109
11-5/8	12.000	1/4 x 16	8-5/8 x 19-1/2	16	21	571	857	87
12	12.750	1/4 x 16	8-5/8 x 19-1/2	16-3/4	21-3/4	520	780	119
12	12.750	3/8 x 24	8-5/8 x 28	17-1/8	29-3/4	796	1194	165
14	14.000	1/4 x 16	8-5/8 x 19-1/2	18	21-3/4	732	1098	130
16	16.000	1/4 x 16	10-5/8 x 19-1/2	21	21-3/4	647	971	148
16	16.000	3/8 x 24	10-5/8 x 28	21	29-3/4	647	971	200
18	18.000	1/4 x 16	10-5/8 x 19-1/2	22	21-3/4	581	872	175
18	18.000	3/8 x 24	10-5/8 x 28	23	29-3/4	581	872	235
20	20.000	1/4 x 16	12-5/8 x 19-1/2	24	21-3/4	526	789	201
20	20.000	3/8 x 24	12-5/8 x 28	25	29-3/4	526	789	269
22	22.000	1/4 x 16	14-5/8 x 19-1/2	26	22-3/4	481	722	224
22	22.000	3/8 x 24	14-5/8 x 28	27	30-3/4	481	722	299
24	24.000	1/4 x 16	14-5/8 x 19-1/2	28	22-3/4	443	665	240
24	24.000	3/8 x 24	14-5/8 x 28	29	30-3/4	443	665	325

1- Middle Rings - Thicker or longer than those listed can be furnished.

2- Bolts - Furnished E-coated steel as standard.

3- Gasket - Information appears on inside back cover.

4- Dimension "L" - Overall length taken with fasteners drawn up finger tight.

5- Working Pressure - Pressure ratings are determined on the basis of Barlow's formula using a working stress equal to one half the minimum yield of the middle ring material.

PRESSURE RATINGS NOTE: Consult factory for pressure ratings that represent your particular product requirements