

VALVE SPEC SHEET

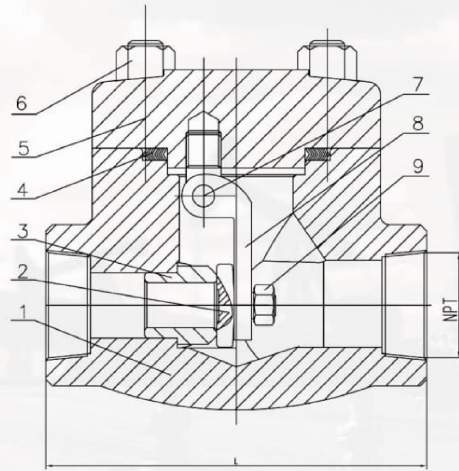

FORGED STEEL CLASS 800 SWING CHECK VALVE

A105 FORGED STEEL BODY
CR13 STAINLESS TRIM
DESIGN API 602
FIRE SAFE API 607
NACE MR-0157 COMPLIANT
THREADS CONFORMS TO
ANSI B1.20.1, BS21, DN 259/2999



No	Part	Material
1	Body	A105
2	Disc	A182 F6a
3	Seat	A182 F6a
4	Gasket	SS+FLEX GRAPHITE
5	Bonnet	A105
6	Bolt	ASTM A193 B7M
7	Pin	PEEK
8	Hinge	GRAPHITE
9	Nut	AISI 304

PRESSURE TEMPERATURE RATING

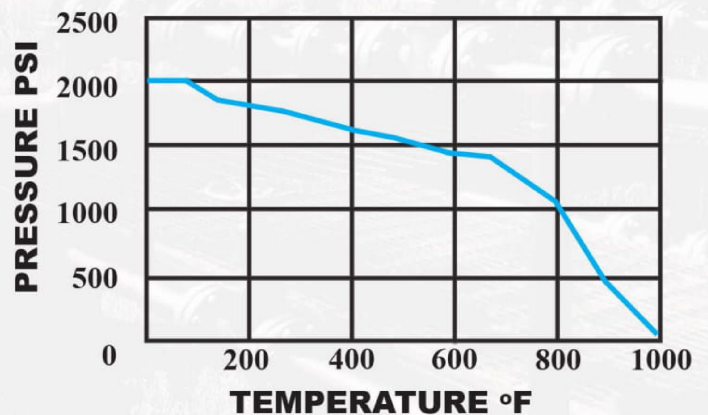

PART#	NPT	NPS	L
FSSCT-800-1/2	1/2"	1/2"	3.11
FSSCT-800-3/4	3/4"	3/4"	3.62
FSSCT-800-1	1"	1"	4.37
FSSCT-800-1 1/2	1-1/2"	1-1/2"	5.98
FSSCT-800-2	2"	2"	6.77