

200MW Mechanical Joint Gate Valve • Spec Sheet



FEATURES & BENEFITS

- ISO-9002
- Ductile Iron MJ Gate Valve
- 250 CWP - Max. Temp 230° F
- AWWA C550 Fusion Bonded Epoxy
- Supplied w/ 2" Square Operating Nut
- MJ Ends Conform w/ AWWA C111/A21.11
- EPDM Resilient Wedge
- Bolted Bonnet
- Non Rising S.S Stem
- Manufactured to AWWA C509-15
- Sizes 3" - 12"

DIMENSIONS

Size (DN)	L	B	F	D	E	H	G
3"	8.00	4.94	7.63	4.06	8.35	12.85	0.95
4"	9.02	6.02	9.13	4.91	9.69	14.18	1.02
6"	10.50	8.13	11.07	7.01	13.00	17.61	1.06
8"	11.50	10.28	13.32	9.16	16.15	20.92	1.10
10"	13.00	12.35	15.63	11.21	13.00	17.61	1.18
12"	14.00	14.45	17.90	13.31	16.15	20.92	1.26

APPLICATIONS

Potable Water, Irrigation, Turf, Sewage Disposal, Golf Course, Water Distribution Service and Feed Lines.

MATERIAL SPECIFICATIONS

No	Part	Material
1	Valve Body	Ductile Iron ASTM A536
2	Resilient Wedge	Ductile Iron ASTM A536/ EPDM ASTM D2000
3	Stem Nut	Bronze ASTM B584
4	Stem	Stainless Steel AISI 410
5	Bonnet	Ductile Iron ASTM A536
6	Stem Primary O-Ring	EPDM ASTM D2000
7	Stem Gasket	NYLON 1010
8	Gland Seal O-Ring	EPDM ASTM D2000
9	Stem Secondary O-Ring	EPDM ASTM D2000
10	Stem Seal Bushing	NYLON 1010
11	Packing Gland	Ductile Iron ASTM A536
12	Wiper Ring	EPDM ASTM D2000
13	Operating Nut	Cast Iron ASTM A126-B
14	Washer	Stainless Steel AISI 410
15	Bolts	Stainless Steel AISI SS304
16	Gland Bolts	Stainless Steel AISI SS304
17	Bonnet Gasket	EPDM ASTM D2000
18	Bonnet Bolts	Stainless Steel AISI SS304

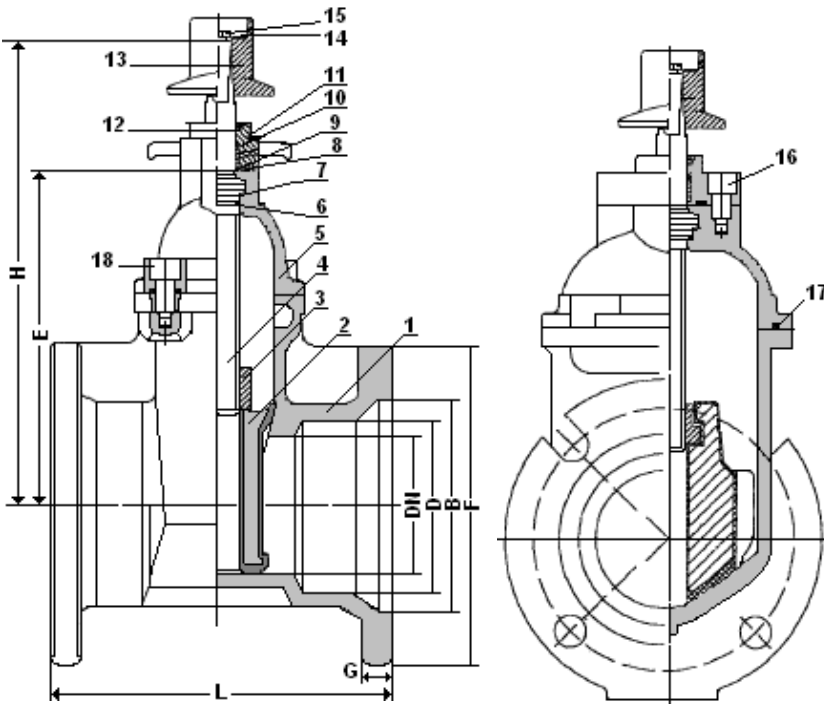

MATCO-NORCA
Global sourcing. National compliance. Local service.

CALIFORNIA 5595 Fresca Dr., La Palma CA 90623
TEXAS 1150 Silber Rd., Houston TX 77055
ILLINOIS 278 Windy Point Dr., Glendale Heights, IL 60139
GEORGIA 113 Industrial Blvd., Americus, Georgia 31709
NEW YORK PO Box 27, Rt.22, Brewster NY 10509
 WEB: www.matco-norca.com

• Phone: 866-532-8306 • Fax: 866-532-8307
 • Phone: 800-935-5456 • Fax: 713-680-2999
 • Phone: 844-412-5068 • Fax: 800-640-2252
 • Phone: 800-433-7526 • Fax: 800-533-5134
 • Phone: 800-431-2082 • Fax: 845-278-9056
 EMAIL: mail@matco-norca.com