



Style 38 and 138 Couplings for CIP/DIP

Dresser Style 38 Couplings are also available for cast and ductile iron pipe sizes 2" through 24". These couplings have long been used for joining plain end cast-iron pipe, combining the advantages of absolutely tight joints and easier, faster pipe joining. Style 38 couplings also permit the salvage and use of random lengths of cast-iron pipe from which bell-ends or cracked sections have been removed.

Dresser Style 138 Couplings for CIP

Now you can stock one coupling in each nominal size, 2" through 16", and be sure of a fit, whether the cast-iron pipe was made in 1890 or from your latest shipment. The unique feature of this product is one middle ring can be used with up to six different gaskets and three followers to cover a wide range of pipes.

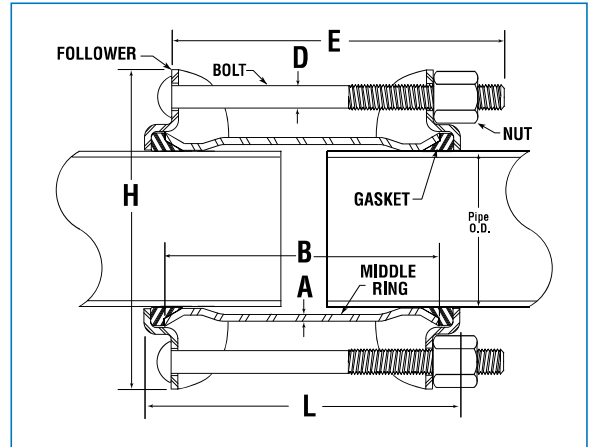

Materials of Construction

Followers: AISI C1012 or ASME SA36 (Ductile Iron or Malleable Iron for 1/2" thru 1-1/2")

Middle Ring: ASTM A513, ASTM A635 or ASME SA675 GR60

Bolts: AWWA C 111/ANSI A21.11

Gaskets: Grade 27 BUNA S

Coating: Fusion-Bonded Epoxy

Style 38 Coupling Sizes and Specifications for Plain-End Cast-Iron Pipe

Pipe Nominal Size (In)	Outside Pipe Diameter (OD)	Middle Ring Thickness & Length (A&B)	Bolts No./Diam. x Length (D&E)	Overall Dimensions		Working Pressure Lbs. per Sq.In.	Approx. Weight Each (Lbs.)
				Diam. (H)	Length (L)		
2	2.500	.180 x 5	3-5/8 x 8-1/4	6-1/2	9-1/2	1500	10
2-1/4	2.750	.203 x 5	3-5/8 x 8-1/4	7	9-1/2	1326	13
4	4.800	.188 x 5	4-5/8 x 8-1/4	9	9-1/2	1100	15
6	6.90 - 7.16	5/8 x 5	5-5/8 x 8-1/4	11	9-1/2	992	21
8	9.05 - 9.36	5/8 x 5	6-5/8 x 8-1/4	13-1/16	9-1/2	772	31
10	11.10 - 11.46	3/8 x 7	7-5/8 x 10-3/4	16	11-7/8	936	47
12	13.20 - 13.56	3/8 x 7	8-5/8 x 10-3/4	18-1/16	11-7/8	794	54
14	15.300	3/8 x 7	10-5/8 x 10-3/4	19-5/16	11-7/8	575	74
14	15.650	3/8 x 7	10-5/8 x 10-3/4	20-5/8	11-7/8	563	102
16	17.400	3/8 x 7	10-5/8 x 10-3/4	19-3/8	11-7/8	509	88
16	17.800	3/8 x 7	10-5/8 x 10-3/4	22-13/16	11-7/8	498	111
18	19.500	3/8 x 7	12-5/8 x 10-3/4	23-1/2	11-7/8	450	105
18	19.920	3/8 x 7	12-5/8 x 10-3/4	24-15/16	9-5/8	448	124
20	21.600	3/8 x 7	12-5/8 x 10-3/4	25-5/8	9-5/8	411	114
20	22.060	3/8 x 7	14-5/8 x 10-3/4	27-1/16	9-3/4	406	141
24	25.800	3/8 x 7	15-5/8 x 10-3/4	29-3/16	9-1/2	349	134
24	26.320	3/8 x 7	15-5/8 x 10-3/4	31-5/16	9-1/2	343	163

NOTE: See Pages 8 for Sizes and Specifications Charts for Style 138 Couplings

Style 138 Couplings Specifications for Plain-End Cast-Iron Pipe

Nom. Size (CIP)	Pipe O. D. Range (In)		Middle Ring Thickness & Length (A&B)	Bolts Number/Diameter & Length (D&E)	Overall Dimensions		Max. Work. Pressure Lbs. per Sq. In.	Approx. Weight Each (Lbs.)
	END 1	END 2			Diam. (H)	Length (L)		
2 2-1/2	2.34 - 2.63 2.65 - 2.88	2.34 - 2.63 2.65 - 2.88	.188 x 5 .180 x 5	2-5/8 x 8-1/4 2-5/8 x 8-1/4	6 6-1/2	9-1/2 9-1/2	250 250	7 8.5
3	3.50 3.80 - 3.96 3.97 - 4.14	3.50 3.80 - 3.96 3.97 - 4.14	3/8 x 5	4-5/8 x 8-1/4	7-3/4	9-1/2	250	12.5
4	4.46 - 4.86 4.80 - 5.10 5.11 - 5.45	4.46 - 4.86 4.46 - 4.86 4.80 - 5.10	3/8 x 5	4-5/8 x 8-1/4	8-13/16	9-1/2	250	15
6	6.56 - 6.96 6.90 - 7.22	6.56 - 6.96 6.90 - 7.22	3/8 x 5	4-5/8 x 8-1/4	11-3/16	9.5/11/5	250	23.5
8	8.00 - 8.16 8.54 - 9.11 9.05 - 9.45 9.05 - 9.45	8.00 - 8.16 8.54 - 9.11 8.54 - 9.11 9.46 - 9.85	3/8 x 5	6-5/8 x 8-1/4	13-5/16	9.5/11/5	250	32
10	10.50 - 10.75 11.10 - 11.60 11.10 - 11.60	10.50 - 10.75 11.10 - 11.60 10.50 - 10.75	3/8 x 7	6-5/8 x 10-3/4	15-3/4	11.5	250	52
12	13.20 - 13.50 13.20 - 13.50 13.90 - 14.20	13.20 - 13.50 12.50 - 12.75 13.20 - 13.50	3/8 x 7	8-5/8 x 10-3/4	17-15/16	11.5	250	55
16	17.40 - 17.80	17.40 - 17.80	3/8 x 7	10-5/8 x 10-3/4	22-13/16	11.5/15	250	80