



KELLER INTERNATIONAL, LLC
1431 LAKE RD, HAMLIN NY 14464
Info@kellerinternational.com
T: 1-800-578-8772 • F: 1-585-964-8093
KELLER4SALON.COM

K1206 Aristo Reclining Salon Chair

STANDARD HG1 BASE



**Factory Safe Weight
Specification:
350 to 400 pounds.**

DELUXE 23" HIGHLAND BASE



- **Factory Safe Weight Specification: 350 to 400 pounds.**
- **American Made – 5 year warranty.**
- **Travel Range of 7" (15.25" to 22.25").**
- **23" diameter plate.**
- **Choosing this base is an upgrade from the Standard HG1 Base.**

DELUXE 27" HIGHLAND BASE



- **Factory Safe Weight Specification: 350 to 400 pounds.**
- **American Made – 5 year warranty.**
- **Travel Range of 7" (15.25" to 22.25").**
- **27" diameter barber chair plate.**
- **Choosing this base is an upgrade from the Standard HG1 Base.**



Dimensions:

Seat Cushion:
21" wide x 18" deep x 3" thick

Back Cushion:
23" wide x 17" high

Armrests:
Inside to Inside: 19"
Outside to Outside: 24"

Floor to Seat Height:
Lowest: 20"
Highest: 26"

Footrest:
16" wide at top
15" wide at bottom
18" tall



**Headrest is
Removable**





- **Sturdy HG1 hydraulic pump and base (standard).**
 - **2-year warranty on the Hydraulic Pump.**
 - **1-year warranty on the Gas Reclining Lever Shock.**
- **Thick cushions wrapped in easy cleaning PVC vinyl.**
- **Reclining handles on both sides of the chair for ease of operation.**
- **U-Shaped footrest.**
- **Headrest is removable.**
- **Ships in one box – FedEx Ground.**
- **Total Weight = 90 pounds.**
 - **Remove Chair, Base, Headrest and Footrest from shipping box.**
 - **Attach the Footrest.**
 - **Place the Chair onto the Hydraulic Base Pump Shaft.**
 - **Insert Headrest into the Headrest Holder.**
 - **Ready to use.**

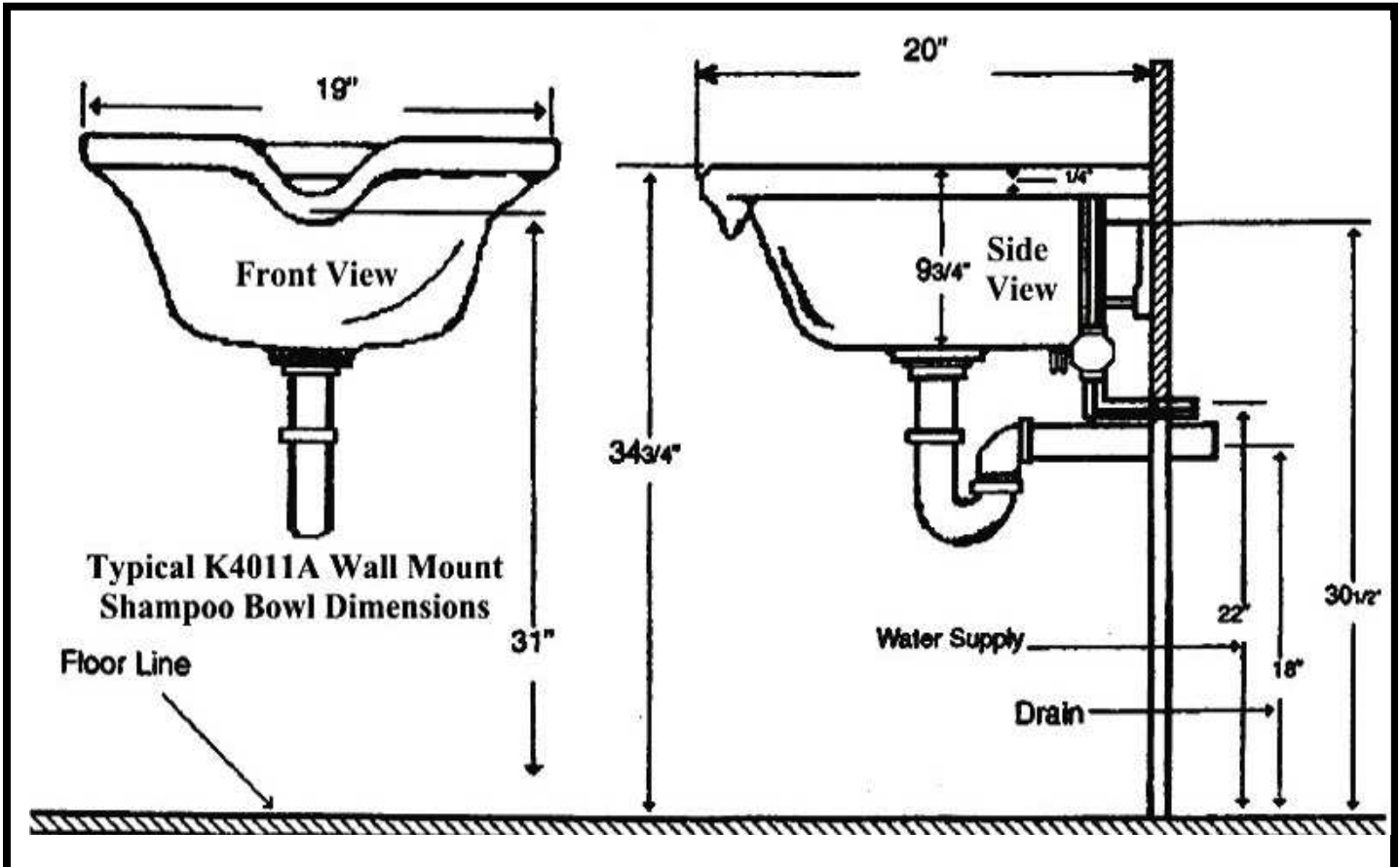

Full Recline - Headrest Removed



This chair as pictured will work with a Keller wall mounted shampoo bowl.



K1206 Footrest Installation Instructions

	<p>Place the chair on a convenient working surface.</p> <p>Remove the 8mm allen bolt from between the two black metal tangs.</p> <p>You may need to loosen the 8mm allen bolt at the back of the seat cushion– DO NOT REMOVE.</p>
	<p>Place the footrest (as shown) between the seat cushion and the two black metal tangs.</p> <p>Remove the two silver 8mm hex head bolts and slide footrest towards the back of the seat cushion.</p>
	<p>Re-install the two silver 8mm hex head bolts through the two black metal tangs.</p> <p>Screw the two silver 8mm hex head bolts into the footrest halfway.</p>
	<p>Re-install the 8mm allen bolt – through the footrest – into the seat cushion.</p> <p>Tighten all bolts – two 8mm allen bolts + two 8mm hex head bolts.</p>