



Kit Contents		
Description	Part No	Pcs
Shock absorber		2
Dust boot		2
Spring		2
Lock nut M14	24627-04	2
Washer	24619-06	2
Lower spring seat	25635-03	2
Lock ring	24636-03	2
Spacer	10422-01	2
Rebound adjuster	24631-02	2
Used for both front and rear:		
C-spanner 1		1
C-spanner 2		1
Öhlins sticker		1
Öhlins Owner's manual		1
Parts needed from BMW:		
31 33 22 29 165 Top mount, left		1
31 33 22 29 166 Top mount, right		1
31 33 22 29 427 Washer		2
31 33 10 90 612 Bearing		2
31 33 10 91 233 Rubber seat		2

👁 Note!

Please note that there can be small differences between your product and the images in these instructions.

👁 Note!

Please note that during storage and transport, especially at high ambient temperature, some of the oil and grease used for assembly may leak and stain the packaging. This will not cause damage to the product, wipe off the excessive oil or grease with a cloth.

👁 Note!

Before you install this product, check the kit contents. If anything is missing, please contact an Öhlins dealer.

⚠ Warning!

Before you install this product, read the Öhlins Owner's manual. This product is an important part of the vehicle and the vehicle stability.

Shock Absorber Kit for BMW 3-series (E46)

BMZ MI35 front

Mounting Instructions

MOUNTING INSTRUCTIONS

⚠ Warning!

We strongly recommend to let an Öhlins dealer install this product.

⚠ Warning!

If you work with a lifted vehicle, make sure that it is safely supported to prevent it from tipping over.

1

Raise the vehicle and put it on jack stands. Ensure that it is securely supported.

2

Remove the front wheels.

3

Loosen the bolts for the lower strut attachments. Support the wheel hubs in an appropriate way on each side of the vehicle so that the brake hoses can not be damaged.

4

Loosen the upper attachments. Remove the original struts from the car.

5

Cut the dust boot 62 mm from the lower end with a pair of scissors according to the figure.

6

Before you install the top mount on the damper, remove the guide screw on the top mounts (BMW part no 31 33 22 29 165 and 31 33 22 29 166).

7

Tighten the lower spring seat and the lock ring to 50 - 60 Nm. Install the dust boot, the spring, the washer, BMW bearing, BMW rubber seat. The BMW top mount, the BMW washer, and the lock nut M14 to the strut according to the figure. Tighten the lock nut to 35 - 40 Nm.

8

Install the Öhlins McPherson struts on the vehicle according to the figure. Fit the stabilizer link.

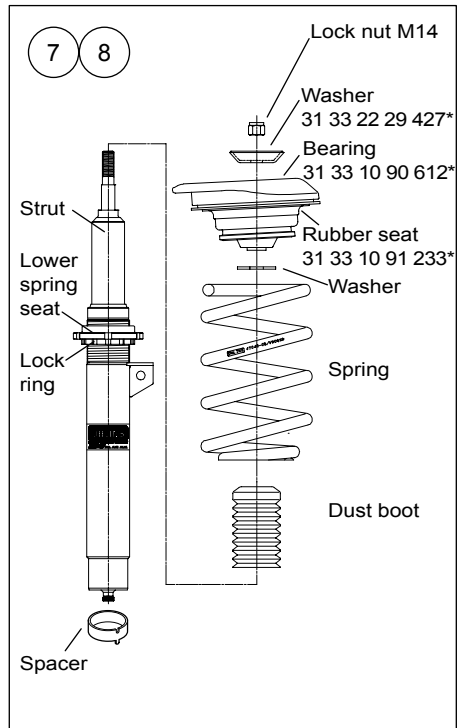
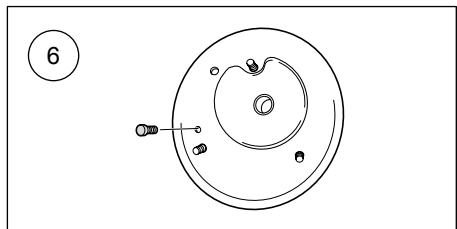
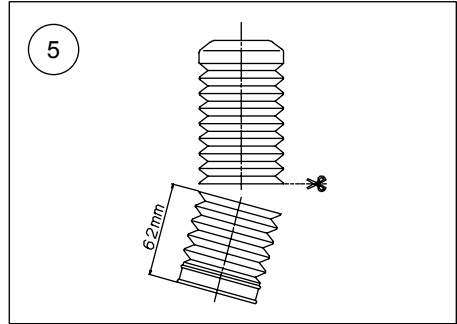

MOUNTING INSTRUCTIONS

9

Fasten the upper attachments.

When you tighten the top mount nut , hold the shock absorber shaft in place with a 6 mm Allen key.

10

Raise the wheel hub with a jack to remove the freeplay of the lower strut attachment bolts before tightening them.

Note!

Make sure that all bolts are tightened to the correct torque and that nothing fouls or restricts movement of the strut when it is being fully compressed or extended. Test this over the whole steering range from lock to lock.

11

Make sure that all removed parts are reinstalled in the same way as they were before the installation of the Öhlins shock absorber.

ADJUSTMENTS

⚠ Warning!

Before you ride/drive, always make sure that the setup is according to the recommended setup data. Read about adjustments and setting up in the Öhlins Owner's Manual before you make any adjustments. Contact an Öhlins dealer if you have any questions about setting up.

SETUP DATA

Rebound setting		
Track	0-7	clicks
Winding road	5-10	clicks
Street	10-20	clicks
Spring preload	14	mm
Shock absorber length	526	mm
Spring		
Spec H200, ID65_103, 70 N/mm		

Actual vehicle height

With both the preload and height adjustments in their standard positions, the vehicle is lowered approximately 20mm lower compared to the M-Sport chassis. As the height adjuster is turned one rotation, the position moves 1.5 mm.

⚠ Warning!

The adjustment range = the standard position -25 to +5 mm.

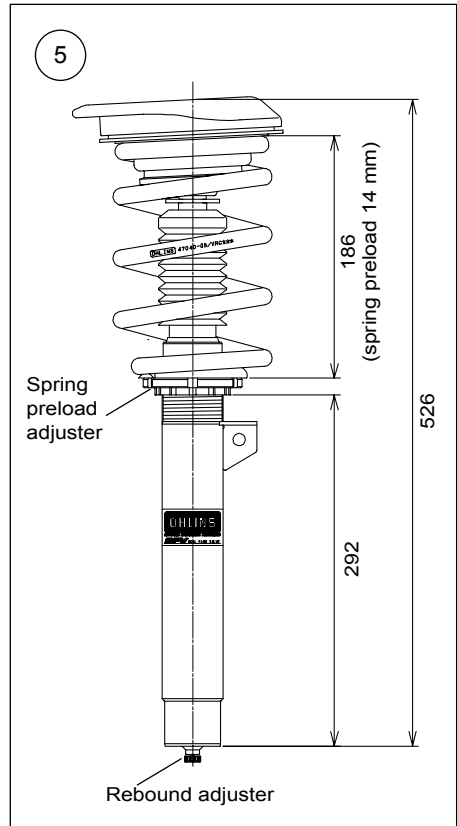

Öhlins products are subject to continuous improvement and development, therefore, although these instructions include the most up-to-date information available at the time of printing, minor updates may occur.

To find the latest information contact an Öhlins distributor. Please contact Öhlins if you have any questions regarding the contents in this document.

Part no. MI_BMZMI35_front_2
Issued 2017-03-01

© Öhlins Racing AB. All rights reserved. Any reprinting or unauthorized use without the written permission of Öhlins Racing AB is prohibited.

Öhlins Racing AB
Box 722
S-194 27 Upplands Väsby, Sweden
Phone +46 8 590 025 00
fax +46 8 590 025 80



www.ohlins.com



Kit Contents		
Description	Part No	Pcs
Shock absorber		2
Spacer	24629-01	2
Lock nut M10	24626-01	2
Screw (M4)	24633-02	2
Handle	24633-01	2
Control wire	24632-04	2
Rebound adjuster	24631-03	2
Allen key		1
Bushing spacer	24629-04	4
Dust boot	10216-01	2
Lock ring	24636-03	4
Spring		2
Spring preload adjuster		2
Rubber seat	25601-03	4
Upper plastic seat	25618-03	2
Lower plastic seat	25618-04	2
Spring seat	24635-03	2
Spring preload adjuster	24635-03	2
Mounted on shock absorber		
Adjuster		2
Used for both front and rear		
C-spanner 1		1
C-spanner 2		1
Öhlins sticker		1
Öhlins Owner's manual		1

👁 Note!

Please note that there can be small differences between your product and the images in these instructions.

👁 Note!

Please note that during storage and transport, especially at high ambient temperature, some of the oil and grease used for assembly may leak and stain the packaging. This will not cause damage to the product, wipe off the excessive oil or grease with a cloth.

👁 Note!

Before you install this product, check the kit contents. If anything is missing, please contact an Öhlins dealer.

⚠ Warning!

Before you install this product, read the Öhlins Owner's manual. This product is an important part of the vehicle and the vehicle stability.

Shock Absorber Kit for BMW 3-series (46)

BMZ MI35 rear

Mounting Instructions



MOUNTING INSTRUCTIONS

⚠ Warning!

We strongly recommend to let an Öhlins dealer install this product.

⚠ Warning!

If you work with a lifted vehicle, make sure that it is safely supported to prevent it from tipping over.

- 1
Raise the vehicle and put it on jack stands.
- 2
Remove the rear wheels.
- 3
Remove the lower and the upper attachments and remove the original shock absorbers.
- 4
Remove the spring.
- 5
Set the spring seat of the spring preload adjuster to the position according to the figure .
- 6
Install the Öhlins spring and the spring preload adjuster on the vehicle according to the figure.
- 7
Cut the dust boot 32 mm from the lower end with a pair of scissors according to the figure.

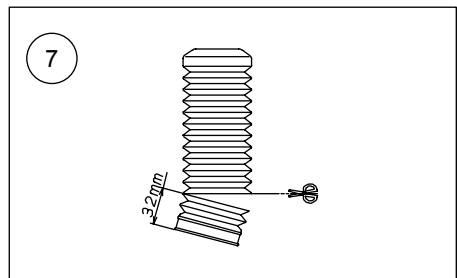
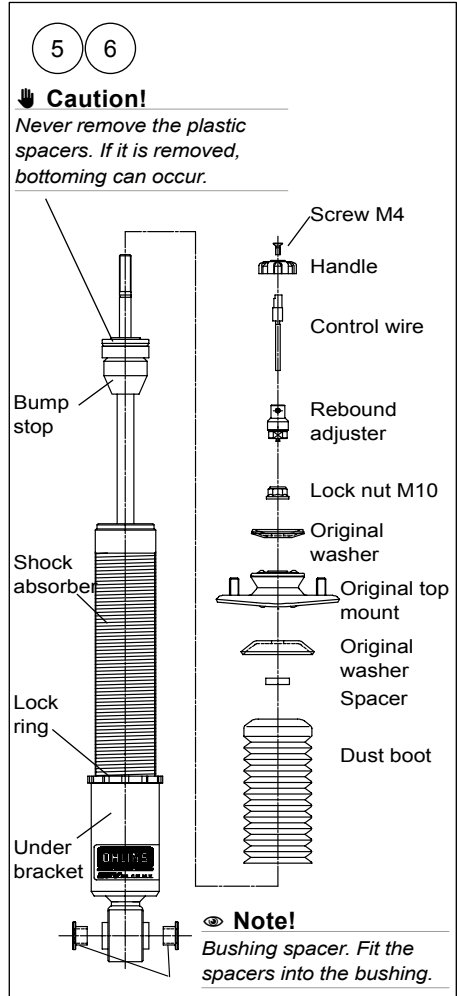

MOUNTING INSTRUCTIONS

8

Install the bushing spacers, the dust boot, the spacer, the original washer, the original topmount, the original washer, the lock nut and the adjuster according to the figure. Tighten the lock nut to 30 Nm.

Note!

When you tighten the lock nut, hold the shock absorber shaft in place with a 5 mm Allen key.

9

Install the Öhlins shock absorbers on the vehicle.

10

Make sure that all removed parts are reinstalled in the same way as they were before the installation of the Öhlins shock absorber.

Note!

Make sure that all bolts are tightened to the correct torque and that nothing fouls or restricts movement of the shock absorber when it is being fully compressed or extended.

11

Sub-assemble the wire.
(Fasten the handle by tightening the M4 screw.) As shown in fig 5, insert the wire through the Ø10 hole made in the side panel, see figure 11, and run it inside the panel.
Insert the top end of the wire into the adjuster and fasten it with the supplied Allen key.

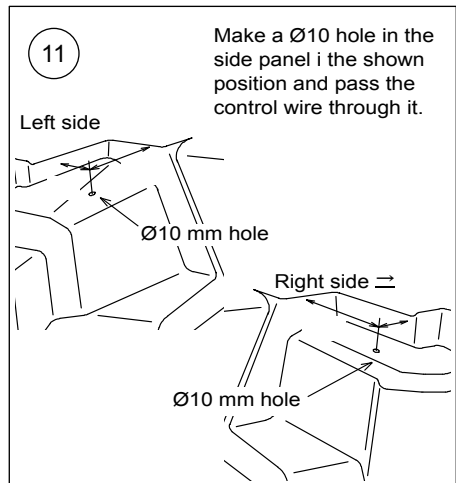
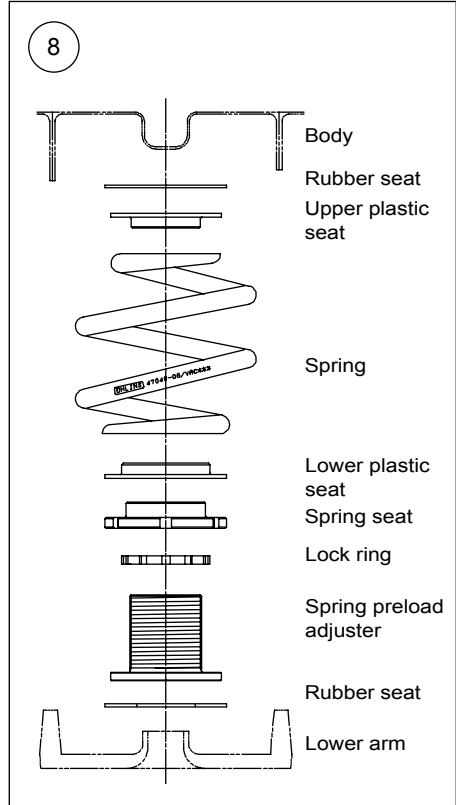

ADJUSTMENTS

⚠ Warning!

Before you ride/drive, always make sure that the setup is according to the recommended setup data. Read about adjustments and setting up in the Öhlins Owner's Manual before you make any adjustments. Contact an Öhlins dealer if you have any questions about setting up.

SETUP DATA

Rebound setting		
Track	0-7	clicks
Winding road	5-10	clicks
Street	10-20	clicks
Spring preload adjuster height	30	mm
Shock absorber length	540	mm
Spring		
Spec H130, ID52-65, 110 N/mm		

Actual vehicle height

With both the preload and height adjustments in their standard positions, the vehicle is lowered approximately 15 mm compared to the M-Sport chassis. As the height adjuster is turned one rotation, the position moves 1.5 mm.

⚠ Warning!

The adjustment range = the standard position -25 to +10 mm.

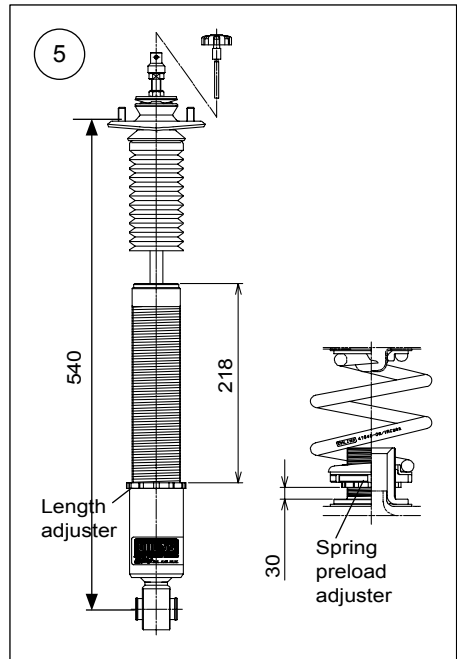

Öhlins products are subject to continuous improvement and development, therefore, although these instructions include the most up-to-date information available at the time of printing, minor updates may occur.

To find the latest information contact an Öhlins distributor. Please contact Öhlins if you have any questions regarding the contents in this document.

Part no. MI_BMZMI35_rear_2
Issued 2017-03-01

© Öhlins Racing AB. All rights reserved. Any reprinting or unauthorized use without the written permission of Öhlins Racing AB is prohibited.

Öhlins Racing AB
Box 722
S-194 27 Upplands Väsby, Sweden
Phone +46 8 590 025 00
fax +46 8 590 025 80



www.ohlins.com