

COMMERCIAL ENTRANCE LEVER LOCK



Product description:

- Commercial entrance lever, reversible for Right and Left doors opening
- Standard Duty Commercial application
- Turn button on the inside lever lock
- Outside locking with key-option
- Commercial Use
- Ships with mounting hardware

Advantages:

- Full length Lever Handle
- Anti-vandal locking mechanism
- Cylindrical body with high strength and durability
- Meets ADA requirements: specially designed for **Barrier free application**
- Concealed mounting crew
- Stainless Steel Latch bolt and Faceplate



Safety:

Meets the requirements of durability, strength and performance according to **ANSI/BHMA A156.2 series 8600 Grade 2 standards**

- Can withstand 2 strikes of 75 pounds of force (90 foot-pounds)
- Tested to withstand 400,000 opening and closing cycles
- Stainless Steel Escutcheon
- Outside Emergency unlock
- Finish is tested for Sault-Organic impact
- Levers are tested for Strength and Optional validity
- Free Wheeling clutch design. Free-turning handle in locked position without door opening, to deter breaking of the handle.

Technical Data:

- **Material:** Zink Alloy Handles, Stainless Steel Escutcheon
- **Door Thickness:** Standard Doors 1-1/2" to 2"
- **Backset:** Standard 2-3/4"
- **Cylinder:** 6-Pin removable core
- **Faceplate:** 1" x 2-1/4" square corner
- **Bolt:** 1" throw
- Dichromate finish for rust resistance

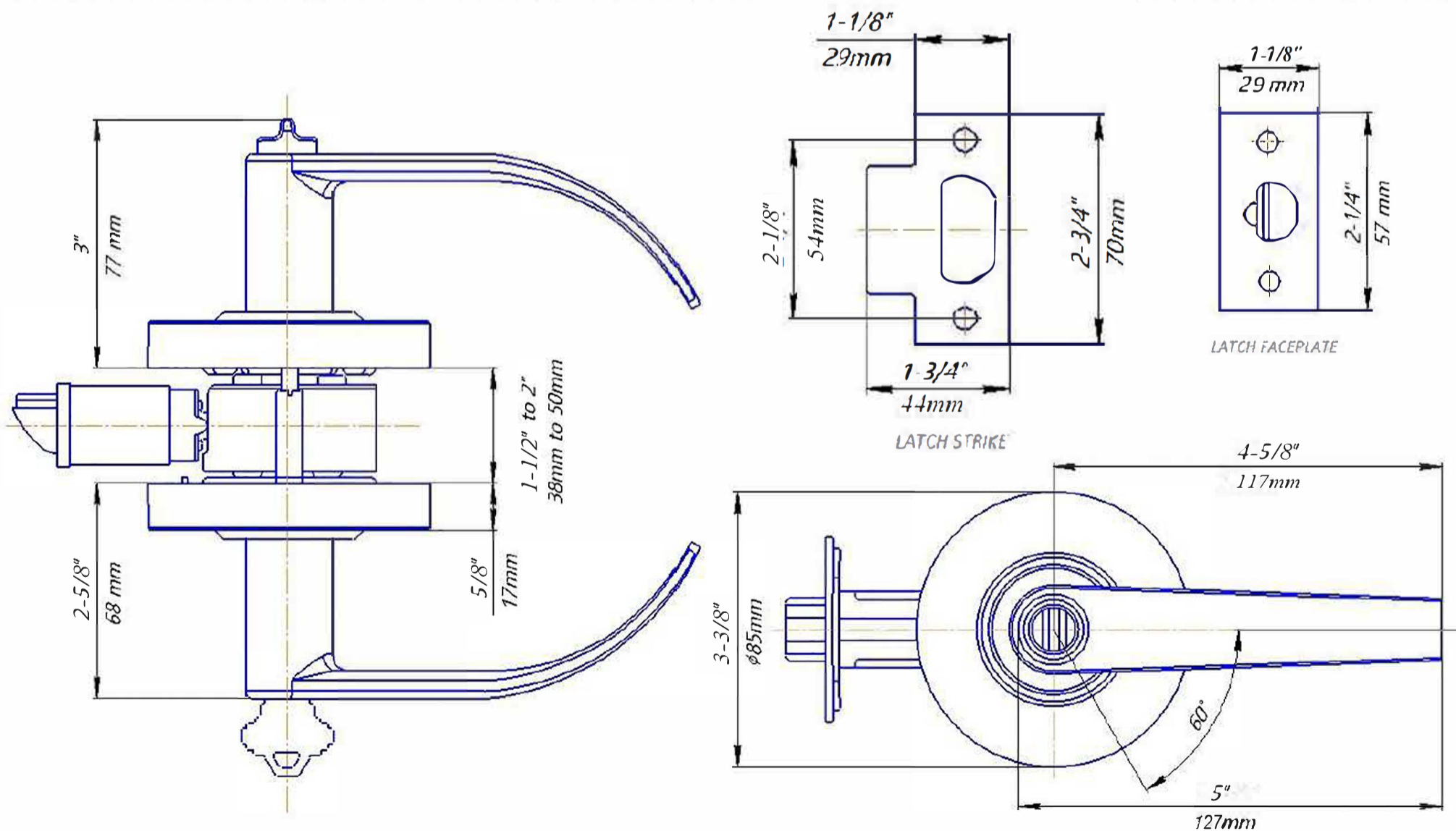

Vizilok Company

Brooklyn, NY 11235

Phone: +1 833 353-1775

Email: info@vizilok.com



USA Technology

