

OCTAVE

Phono EQ.2

Owner's Manual  
English

## FOREWORD

Congratulations and thank you for choosing the OCTAVE phono preamplifier

## Phono EQ.2

Alongside the drive and pickup cartridge, the phono preamplifier plays a crucial role in the playback quality of analog records. This is why OCTAVE offers a perfectly coordinated phono input, including for retrofitting, with sophisticated equalization (RIAA curve) and comprehensive adaptation options to fit the pickup cartridge system for nearly all its preamplifiers and integrated amplifiers.

Unfortunately, in this day and age integrated amplifiers and preamplifiers of other makes no longer feature a phono input, or they are rarely able to meet the requirements for high-quality analog playback with their integrated solutions. OCTAVE has designed the **Phono EQ.2** for all the music enthusiasts who want to optimally integrate their record player into their existing reproducing chain. An external phono preamplifier in a magnetically shielded housing, developed with the same uncompromising demand for fidelity which also characterizes the phono modules.

It is irrelevant whether the pickup arm is equipped with an MM (moving magnet) or MC (moving coil) system. Thanks to practical impedance and gain adjustment, the inputs can be adjusted optimally to the sensitive pickup cartridge voltages. The equipment also features a premium subsonic filter that effectively protects the woofer diaphragm from undesired, low-frequency signal components. The external, low stray field wall adapter power supply effectively suppresses 50 Hz power oscillations and keeps them as far away from the sensitive signals as possible. OCTAVE uses only high-quality gold-plated connections and carefully selected components from choice manufacturers.

Take care of it, and your preamplifier will provide you with many years of listening pleasure.

We hope you will enjoy many hours of wonderful music with your OCTAVE preamplifier.



Andreas Hofmann

## CONTENT

<b>1.</b>	<b>OCTAVE TECHNOLOGY</b>	<b>2</b>
1.1.	OCTAVE amps in contrast to other equipment	2
1.2.	Description Phono EQ.2	2
1.3.	RIAA equalization	3
<b>2.</b>	<b>SAFETY INSTRUCTIONS</b>	<b>4</b>
2.1.	Before you begin	4
2.1.1.	In case of emergency: disconnect the plug from the mains supply	4
2.1.2.	Service and maintenance	4
2.1.3.	Before connecting	4
2.2.	Placement	4
2.3.	Warranty	5
<b>3.</b>	<b>DEVICE OVERVIEW</b>	<b>5</b>
3.1.	Phono EQ.2 front panel	5
3.2.	Phono EQ.2 rear panel	6
3.3.	Bottom of Phono EQ.2	7
<b>4.</b>	<b>CONNECTION</b>	<b>8</b>
<b>5.</b>	<b>OPERATION</b>	<b>8</b>
5.1.	Setting the input impedance for MC pickup cartridge systems	8
5.2.	Setting the gain for MC pickup cartridge systems	9
<b>6.</b>	<b>TROUBLESHOOTING</b>	<b>10</b>
6.1.	Troubleshooting	10
<b>7.</b>	<b>TECHNICAL DATA</b>	<b>11</b>
7.1.	Phono moving magnet	11
7.2.	Phono moving coil	11
7.3.	General data	12
7.4.	Dimensions	12
7.5.	Diagrams	13
7.5.1.	Phono MC frequency response, RIAA	13
7.5.2.	Hum and noise level	13

## OCTAVE TECHNOLOGY

### 1. OCTAVE TECHNOLOGY

#### 1.1. OCTAVE amps in contrast to other equipment

**Hand built** OCTAVE amplifiers are hand built and individually tested. They are designed and developed by Andreas Hofmann.

**Made in Germany** OCTAVE amplifiers are 100% built in Germany. Our employees are highly qualified and committed. We collaborate closely with local specialist subcontracting companies. The hardware components are all manufactured on modern CNC machines.

#### 1.2. Description Phono EQ.2

The **Phono EQ.2** is an external phono preamplifier for MM and MC pickup cartridge systems. Separate, switchable RCA sockets are available to connect the two systems. Gain and input impedance can be adapted to the MC system via the switch on the bottom of the equipment. An external wall adapter serves as the power supply.

## OCTAVE TECHNOLOGY

### 1.3. RIAA equalization

A record player is an electro-mechanical device. Music signals are “pressed” into the grooves in the record, and these are physically tracked and read by the pickup cartridge. In order to get the entire 20 Hz to 20 KHz frequency range into the grooves, the frequency response has to be shaped by lowering the level of the low-frequency information and raising the level of the high-frequency information. This predefined equalization curve is known as RIAA equalization.

A phono preamplifier must be able to reproduce the RIAA equalization precisely to avoid coloring the sound. Equalization accuracy must be within 0.5 dB over the entire frequency range, with channel matching of at least 0.1 dB.

The **Phono EQ.2**'s input amplifier raises the different signals of the pickup cartridge to a constant, high level, which the RIAA amplifier can optimally process.

#### IDEAL RIAA DE-EMPHASIS (3180. 318, 75 $\mu$ s)

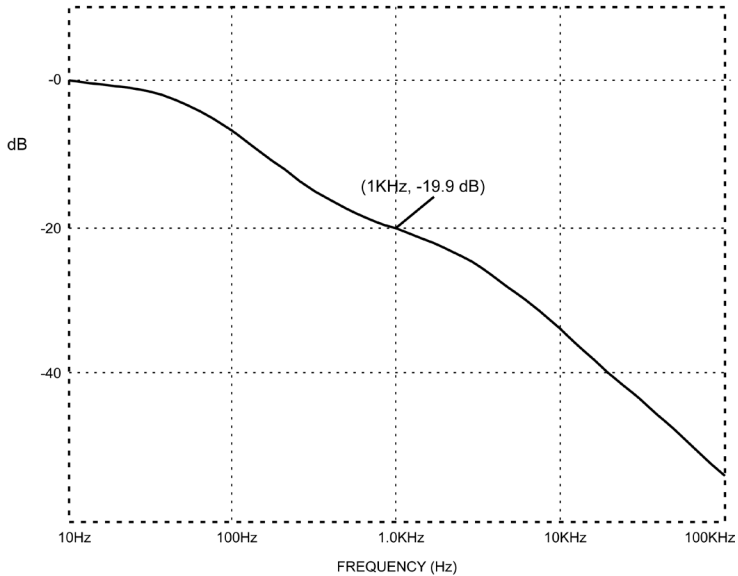

**SAFETY INSTRUCTIONS****2. SAFETY INSTRUCTIONS****2.1. Before you begin****2.1.1. In case of emergency: disconnect the plug from the mains supply**

Never use an amplifier that is damaged or faulty. Make sure it has been labeled as defective and that it cannot be used until it has been repaired by a qualified service engineer.

**2.1.2. Service and maintenance**

For reasons of safety, please ensure that servicing, repairs and other modifications to OCTAVE equipment are carried out only by a qualified technician. Defective fuses should also only be replaced by a qualified technician. Always replace fuses with ones of the same type and rating. If your amplifier requires servicing, please ship or take your equipment directly to OCTAVE or to one of our authorized service centers.

**2.1.3. Before connecting**

Make sure that the voltage of your wall adapter power supply matches your local supply voltage.

**2.2. Placement**

- The equipment is designed strictly for use in a dry domestic environment. Do not use it in open air or in damp environments!
- Never place plants or liquid-filled containers on the equipment. Take care that objects do not fall or liquids are not spilled into the enclosure. Should this happen, disconnect the mains plug immediately and have your amplifier checked by a qualified service technician.
- Condensation may form if the amplifier is taken from a cold environment into a warm one. In this case, wait until the amplifier has reached room temperature and is dry before switching it on.
- Avoid installing the amplifier close to sources of heat, such as heaters, or anywhere that it may be in direct sunlight.
- Do not operate the equipment near flammable materials, gases, or vapors. Avoid areas where there may be heavy accumulations of dust or where the amplifier may be subject to mechanical vibration.
- Place your equipment on a stable, even surface.

## DEVICE OVERVIEW

### 2.3. Warranty

OCTAVE can only guarantee the safety, reliability and performance of this unit if modifications and repairs are carried out by specialized personnel and if the amplifier is operated in accordance with the instructions contained in this manual.

## 3. DEVICE OVERVIEW

### 3.1. Phono EQ.2 front panel

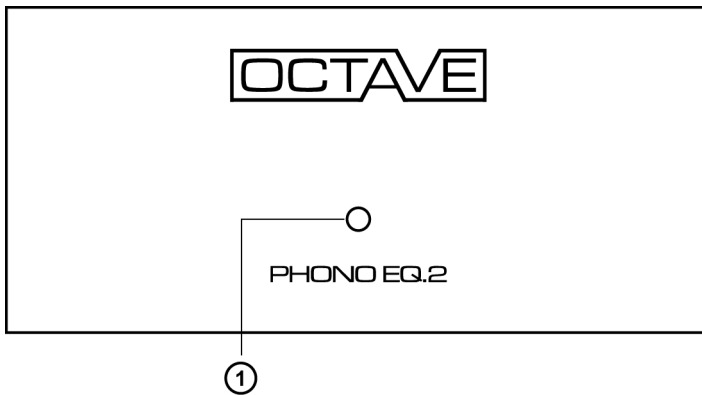

#### Legend

(1)	<b>Light-emitting diode (LED)</b>	The LED lights up when a power supply is connected.
-----	-----------------------------------	---

DEVICE OVERVIEW

3.2. Phono EQ.2 rear panel

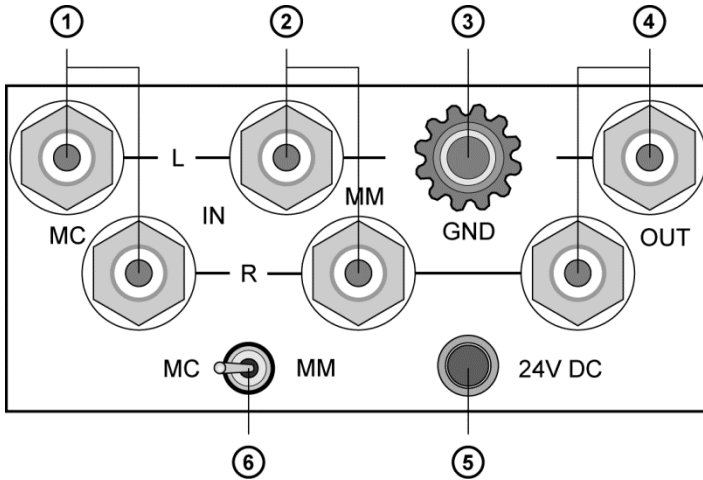

Legend

(1)	<b>MC input</b> (L = left; R = right)	RCA input for MC pickup cartridge systems
(2)	<b>MM input</b> (L = left; R = right)	RCA input for MM pickup cartridge systems
(3)	<b>GND</b>	Ground connection
(4)	<b>Output</b> (L = left; R = right)	RCA output
(5)	<b>24V DC</b>	Connection for the external power supply
(6)	<b>MC/MM toggle switch</b>	To switch between MC input and MM input



DEVICE OVERVIEW

3.3. Bottom of Phono EQ.2

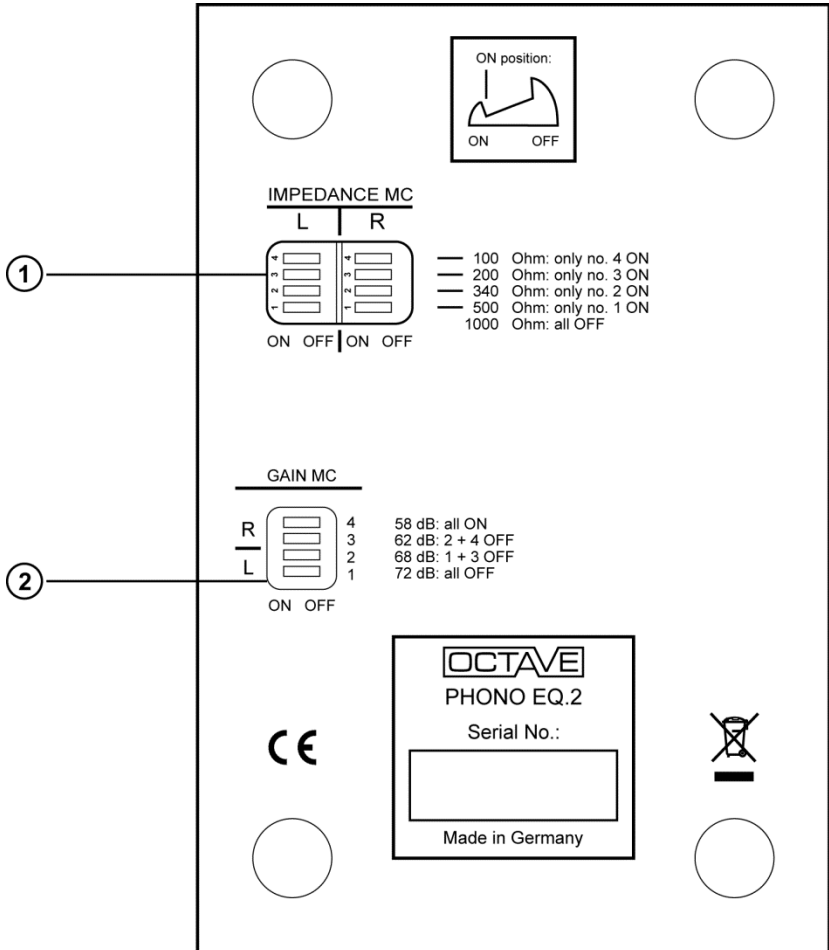

Legend

(1)	<b>IMPEDANCE MC</b>	Adjustment of the MC pickup cartridge system input impedance
(2)	<b>GAIN MC</b>	Adjustment of the gain for MC pickup cartridge systems. Gain adjustment allows for adjustment of the MC input to low and high output systems.

## CONNECTION

## 4. CONNECTION

- ▶ Please observe the safety instructions and positioning information (see chapter 2, page 4).
- 1. Before connecting the preamplifier, switch off all other equipment that you intend to connect to it.
- 2. Move the MM/MC toggle switch to the setting for the desired pickup cartridge system (see section 3.2, item (6)).
- 3. Depending on the pickup cartridge system, connect the MM/MC pickup cartridge system to the MM or MC inputs on the **Phono EQ.2** (see section 3.2, items (1) and (2)).
- 4. If you have connected an MC pickup cartridge system, set the input impedance and the gain (see section 5.1, page 8, and section 5.2, page 9).
- 5. Connect the ground cable to the ground connection on the pickup cartridge system (see section 3.2, item (3)).
- 6. Connect the **Phono EQ.2** outputs (see section 3.2, item (4)) to the inputs on the preamplifier/integrated amplifier.
- 7. Plug in the **Phono EQ.2** wall adapter power supply (see section 3.2, item (5)).
- 8. Switch the equipment on in the order “from the source to the loudspeakers”.

## 5. OPERATION

## 5.1. Setting the input impedance for MC pickup cartridge systems

The input impedance value is important for balanced pickup cartridge sound.

1. Please see the technical data or the pickup cartridge system’s owner’s manual for the recommended impedance.
2. Set the recommended input impedance according to the following table. If the recommended input impedance is not listed in the table, use the closest value. If two values are possible, you can select the optimal input impedance using a listening test.

	Switch no.			
	1	2	3	4
1000 ohms	●	●	●	●
500 ohms	○	●	●	●
340 ohms	●	○	●	●
250 ohms	○	○	●	●
200 ohms	●	●	○	●

**OPERATION**

170 ohms	○	●	○	●
146 ohms	●	○	○	●
125 ohms	○	○	○	●
100 ohms	●	●	●	○
97 ohms	○	●	●	○
75 ohms	●	●	○	○
66 ohms	●	○	○	○
62 ohms	○	○	○	○

● = OFF / ○ = ON

On delivery, the impedance is set to 100 ohms: This setting is optimal for most low-output MC pickup cartridge systems.

**5.2. Setting the gain for MC pickup cartridge systems**

Gain adjustment allows for adjustment of the MC input to different low and high output systems.

1. Please see the technical data or the pickup cartridge system's owner's manual for the gain.
2. Set the gain according to the following table. If the recommended gain is not listed in the table, use the closest value. If two values are possible, you can select the optimal gain using a listening test.

		Switch no.			
		1	2	3	4
58 dB	Gain low	●	●	●	●
62 dB	...	●	○	●	○
68 dB	...	○	●	○	●
72 dB	Gain high	○	○	○	○

● = OFF / ○ = ON

## TROUBLESHOOTING

## 6. TROUBLESHOOTING

## 6.1. Troubleshooting

**Hum and crackling**

Hum in an audio system is often caused by several system components being grounded individually. It is particularly common with tuners, VCRs, or satellite receivers, where the grounded aerial cables cause a ground loop via the aerial input. Power amplifiers are normally also grounded. Removing the ground wire on your safety plugs is not a solution. You can isolate the aerial earth connection with a special signal isolator. This device has no adverse effect on the sound or picture quality of tuners or TVs.

**Solution** The **Phono EQ.2** ground connection may remain unused to interrupt a ground loop with the grounded source device.

---

**Clicks and pops**

Older refrigerators and 12 V halogen lamps can generate strong radio interference, and when they are switched on and off, audible clicks and pops in the system's loudspeakers may occur.

**Solution** The only solution is to use a single-power socket board for your entire system and to use a different power outlet in your listening room.

---

**Channels are not balanced**

Check that the RCA plugs are plugged in properly. Bend the outer ground contacts inward if necessary. Sometimes the internal pin in an RCA plug may not be a tight enough fit, in which case you should either replace the cable or the socket.

Damaged cables and poorly fitting RCI plugs can create resistance in the signal path, enough to reduce the output level of one channel.

**Solution** Try new cables or clean plugs and sockets with isopropyl alcohol. You could also try cleaning or contact fluid.

---

**No sound**

MM/MC setting and cable connection incorrect.

**Solution** Check the position of the MM/MC toggle switch and the RCA cable.

---

## TECHNICAL DATA

## 7. TECHNICAL DATA

## 7.1. Phono moving magnet

Phono MM	
Frequency response	+/- 0.25 dB RIAA / 25 Hz – 20 kHz
Input sensitivity	4 mV
Gain	50 dB
Input capacity	220 pF
Input impedance	47 kohms
Output impedance	100 ohms
Signal-to-noise ratio	-90 dB/2.5 V output level
Maximum input level	19 mV at 1 kHz
Total harmonic distortion	0.008% at 5.4 V RMS

## 7.2. Phono moving coil

Phono MC	
Frequency response	+/- 0.1 dB RIAA / 25 Hz – 20 kHz
Input sensitivity	100 $\mu$ V – 1 mV
Gain	58 dB, 62 dB, 68 dB, 72 dB (adjustable)
Input impedance	62 ohms – 1 kohm
Output impedance	100 ohms
Signal-to-noise ratio (input short-circuited at gain of 72 dB)	-74 dB/2.5 V output level
Signal-to-noise ratio (input short-circuited at gain of 52 dB)	-86 dB/2.5 V output level
Maximum input level	2.3 mV at 1 kHz
Total harmonic distortion	0.008% at 5.4 V RMS

## TECHNICAL DATA

## 7.3. General data

General data	
Power consumption	< 2 W
Weight of preamplifier	0.8 kg
Weight of power supply	0.1 kg
Dimensions of power amplifier	Width x height x depth = 100 x 55 x 167 mm
Dimensions of power supply	Width x height x depth = 50 x 55 x 40 mm
Supplied accessories	External power supply

## 7.4. Dimensions

## Unit dimensions (in mm)

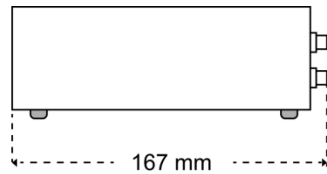
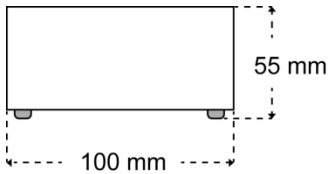

## 7.5. Diagrams

### 7.5.1. Phono MC frequency response, RIAA

Frequency response with subsonic filter

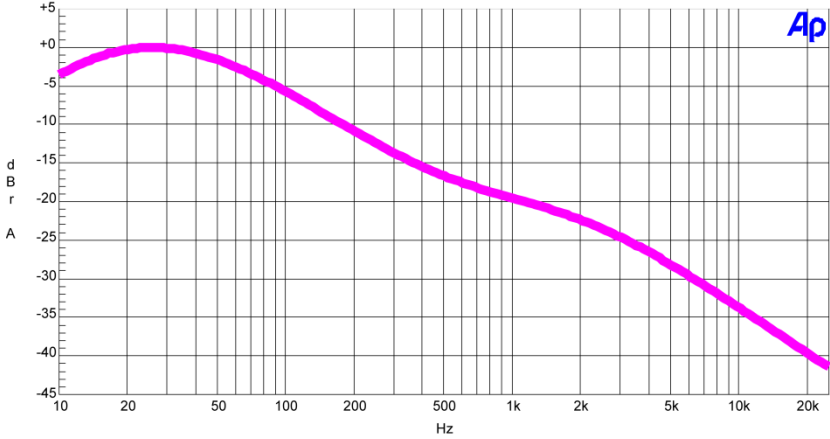

### 7.5.2. Hum and noise level

Hum and noise level with MC, gain = 58 dB

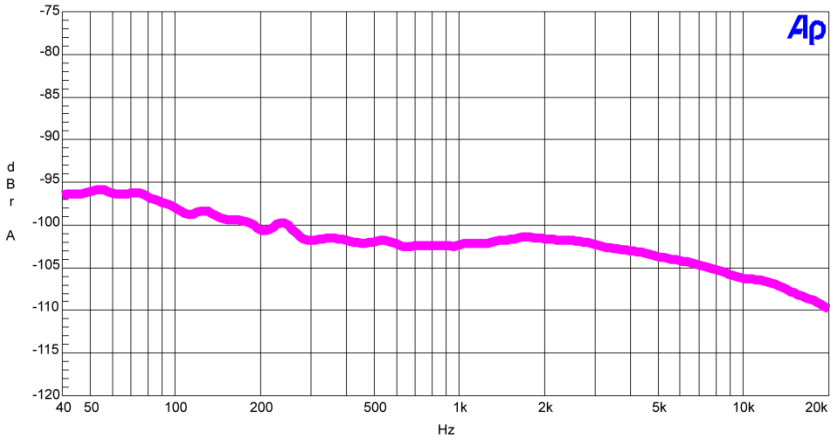

The logo for OCTAVE, featuring the word "OCTAVE" in a stylized, outlined font within a rectangular border.

We reserve the right to alter and improve the specifications in pursuit of better. OCTAVE is a registered trademark of Andreas Hofmann Octave Audio. This manual is the copyright of Andreas Hofmann.

Reproduction in whole or part is prohibited.

EN2015.02

OCTAVE AUDIO  
Germany  
[www.octave.de](http://www.octave.de)

A solid dark grey horizontal bar at the bottom of the page.







ANDREAS HOFMANN  
OCTAVE AUDIO  
INDUSTRIESTR. 13  
76307 KARLSBAD  
GERMANY  
TEL +49 72 48 / 32 78  
FAX +49 72 48 / 32 79  
HOFMANN@OCTAVE.DE  
WWW.OCTAVE.DE

