

element · 

MUSIC STREAMER COMBO

User Manual

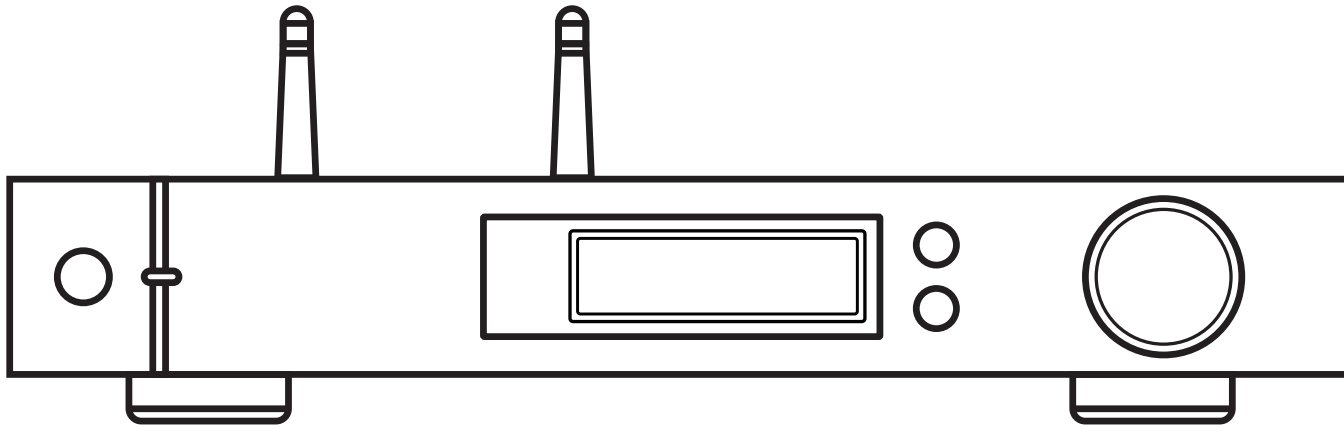

HIGH PERFORMANCE AUDIO

www.matrix-digi.com

Matrix Electronic Technology Co., Ltd.
+86-29-86211122
B-801, No.111 Fengcheng 5th Rd.,
Xi'an, China
support@matrix-digi.com



Catalog

1. Packing list	01	4.1.2 Select the input source	08	5.9 User defined button settings	14
2. Parts and name	01	4.1.3 Volume control	09	5.10 Network Type	14
2.1 Front panel	01	4.1.3.1 Volume adjustment	09	5.11 Remote Control	15
2.2 Rear panel	02	4.1.3.2 Mute	09	5.12 Load Default	15
2.3 Display screen	02	4.1.3.3 Hearing protection	09	5.13 Product information	15
2.3.1 Display in main interface area	02	4.1.4 Filter settings	10	6. Appendix	15
2.3.2 Volume control	03	4.1.5 Auto sleep and wake up	10	6.1 File formats and sampling rate supported ..	15
2.3.3 Display for input channel	03	4.1.6 Remote control	10	6.2 About MQA	15
2.4 Remote control	03	4.2 Play music through optical, coaxial or IIS-LVDS port	11	6.3 USB storage device requirements	16
3. Connection	04	4.3 Play music through AirPlay or DLNA	11	6.4 IIS-LVDS Port	16
3.1 Connect to AC power	04	4.4 Play music in USB storage devices\SD Card\NAS	11	6.5 Technical specifications	17
3.2 Connect to input source	05	4.5 USB Audio mode	11		
3.3 Connect to speakers	05	5. Settings	13		
3.4 Connect to storage devices	06	5.1 PCM Filters	13		
3.5 Connect to LAN	06	5.2 DSD Filters	13		
3.6 Connect to WLAN	07	5.3 Dither	13		
4. Play	08	5.4 Jitter Eliminator	13		
4.1 Basic operation	08	5.5 DPLL Bandwidth	14		
4.1.1 Power on	08	5.6 IIS-LVDS Port Definition	14		
		5.7 Dimmer	14		
		5.8 Auto Sleep	14		

1. Packing list

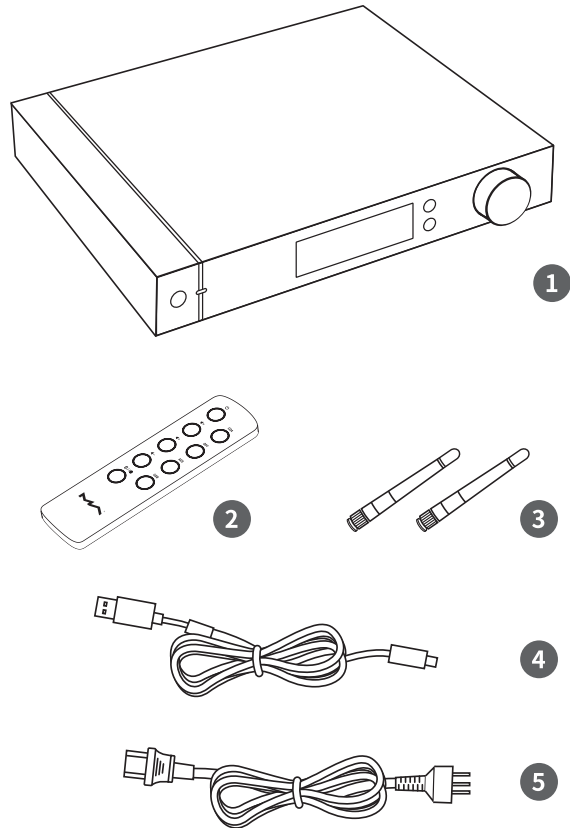

1. Product ×1

2. Remote ×1

3. Wi-Fi antenna ×2

4. USB cable ×1

5. Power cable ×1

2. Parts and name

2.1 Front panel

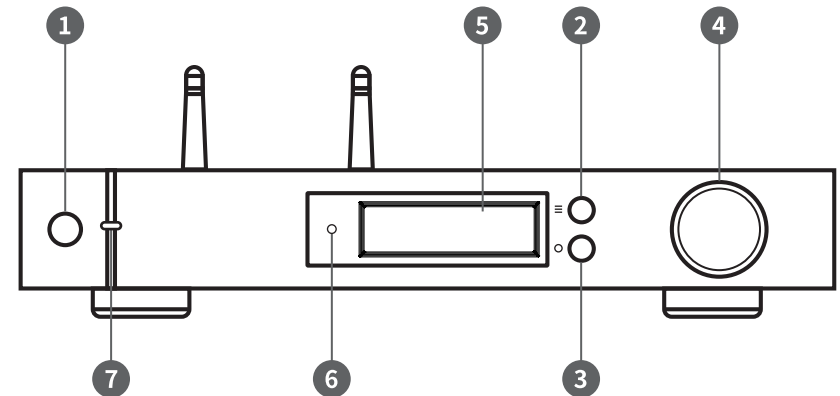

1. Standby

2. Menu

3. User-defined

4. Volume/control knob

5. Display

6. Remote control sensor

7. Indicator light

2.2 Rear panel

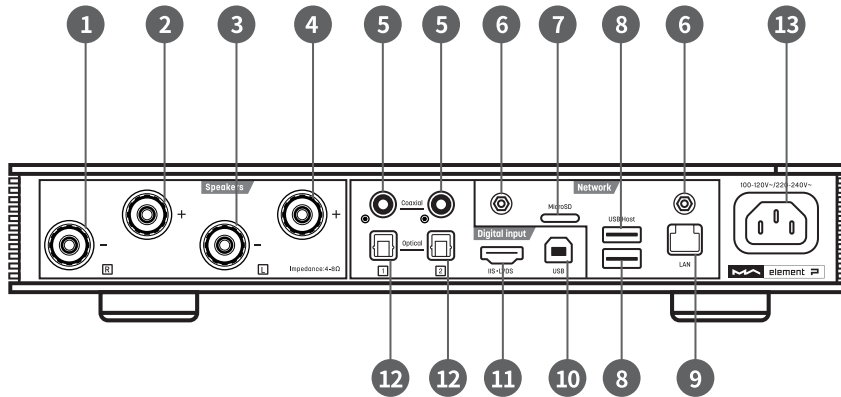

- 1. Right channel speaker - output
- 2. Right channel speaker + output
- 3. Left channel speaker - output
- 4. Left channel speaker + output
- 5. Coaxial input
- 6. Wi-Fi antenna jack
- 7. MicroSD card slot
- 8. USB HOST port
- 9. LAN port
- 10. USB Audio port
- 11. IIS·LVDS input
- 12. Optical input
- 13. Power input

2.3 Display screen

2.3.1 Display in main interface area

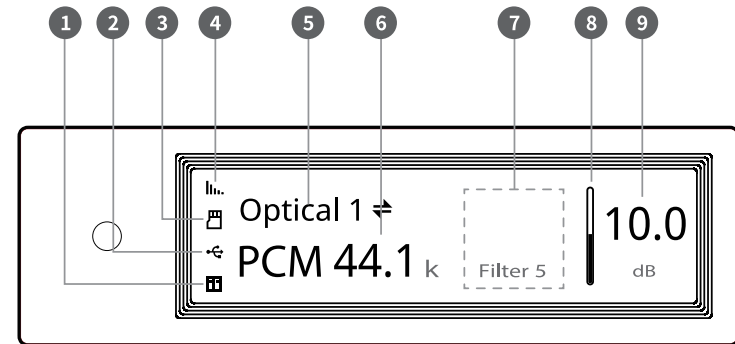

- 1. NAS connection status
- 2. USB storage device connection status
- 3. MicroSD card status
- 4. Wi-Fi and LAN connection status
- 5. Input channel
- 6. Sampling rate
- 7. Auxiliary information
- 8. Volume bar
- 9. Output volume dB level

2.3.2 Volume control

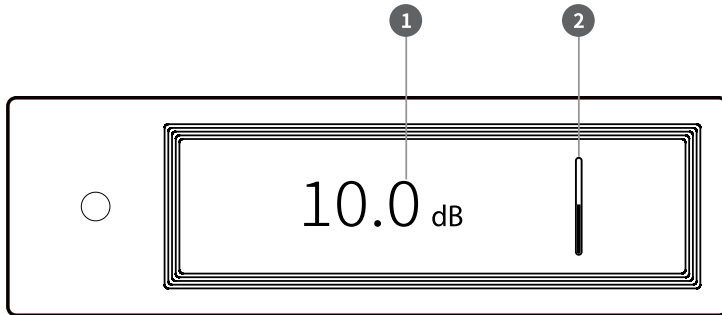

- 1. Current volume dB level
- 2. Volume bar

2.3.3 Display for input channel

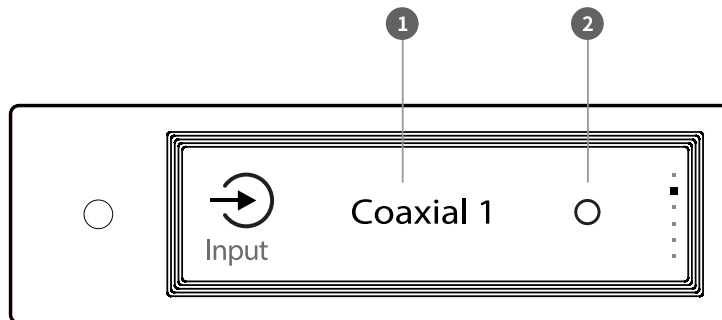

- 1. Input channel
- 2. Select indicator

2.4 Remote control

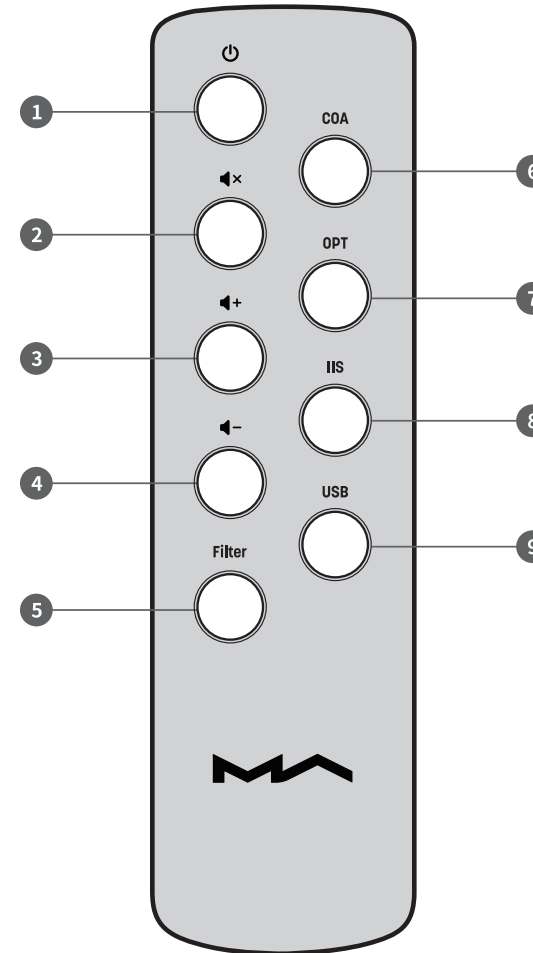

- 1. Standby
- 2. Mute
- 3. Volume+
- 4. Volume-
- 5. Filter
- 6. Coaxial
- 7. Optical
- 8. IIS
- 9. USB/Network*

*This button can switch input channels between USB and Network.

3. Connection

3.1 Connect to AC power

element P is compatible with AC100-120V and AC220-240V power specifications.
Please make sure to switch the bottom power voltage according to your local voltage environment before using. As shown:

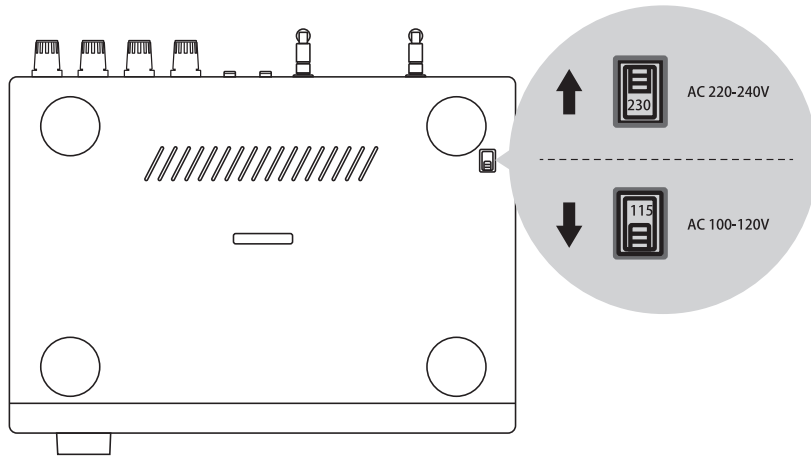

The two sections of the voltage switch are 115V and 230V, each section for:

115V position is fit for AC100V-120V 50/60Hz

230V position is fit for AC220V-240V 50/60Hz

Please use the right three-phase power cable which includes the ground terminal and ensure the ground is reliable connected, or you will have a sense of electric shock when you touch it.

Please unplug the power cable, if you need the element P is disconnected the power thoroughly.

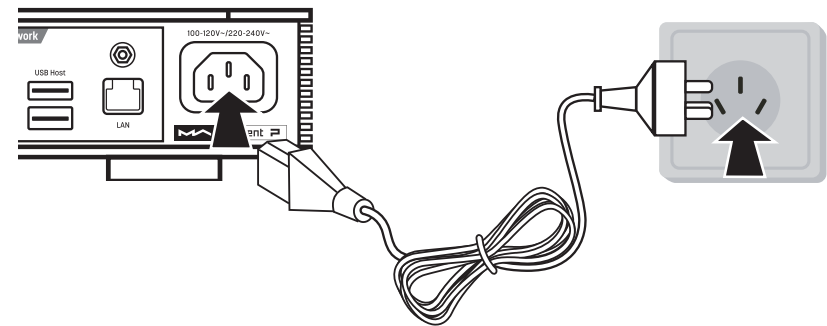

3.2 Connect to input source

Connect to front-end devices including S/PDIF output signal through coaxial and optical port, connect to Matrix digital audio interface products through IIS port.

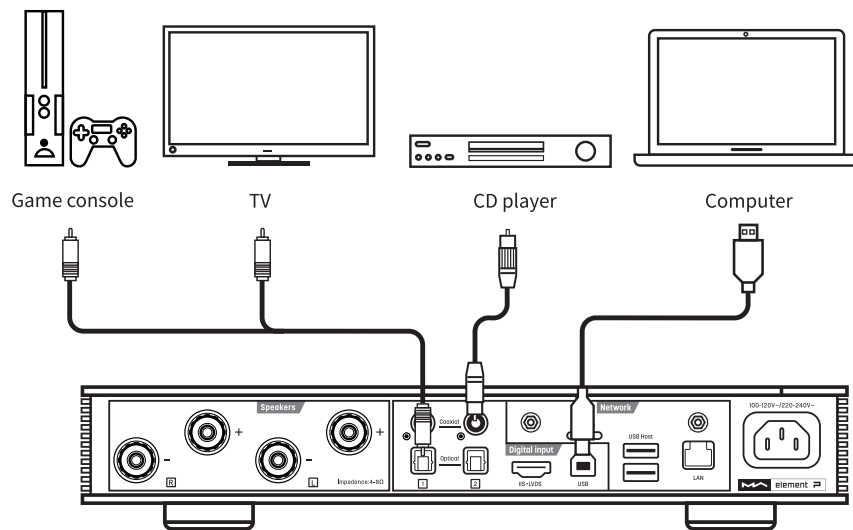

3.3 Connect to speakers

Connect 4-8Ω passive speakers to the connectors at the rear panel of element P. Please disconnect the power supply of element P before connect the speakers to it, and make sure the speaker cables are not shorted.

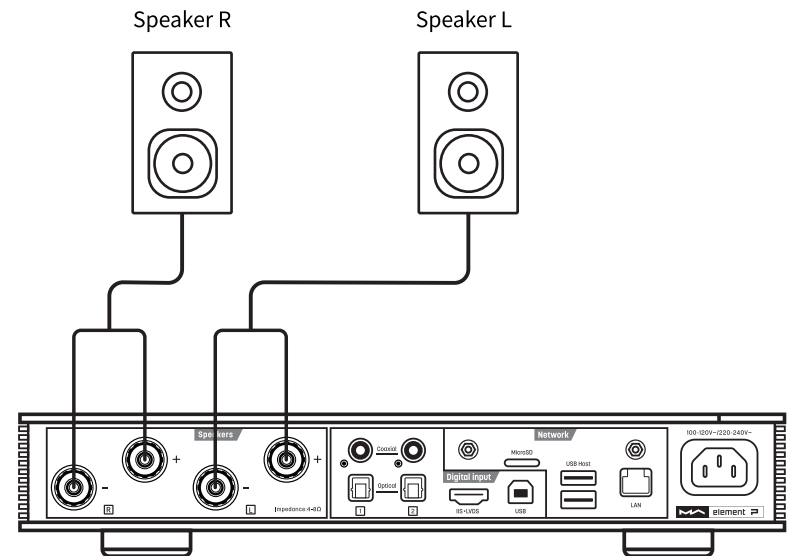

3.4 Connect to storage devices

There are two USB Host ports on the rear panel to connect with standard mass storage USB devices.

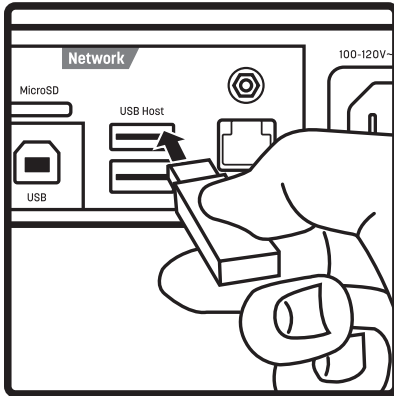

The MicroSD card support up to 128GB, push to install or popup the card.

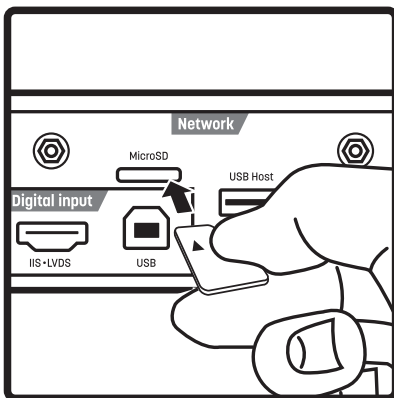

3.5 Connect to LAN

Connect to LAN, please use ethernet cable to connect element P with router (recommend using CAT-5 or higher version shield ethernet cable), and let element P in the network status as shown below:

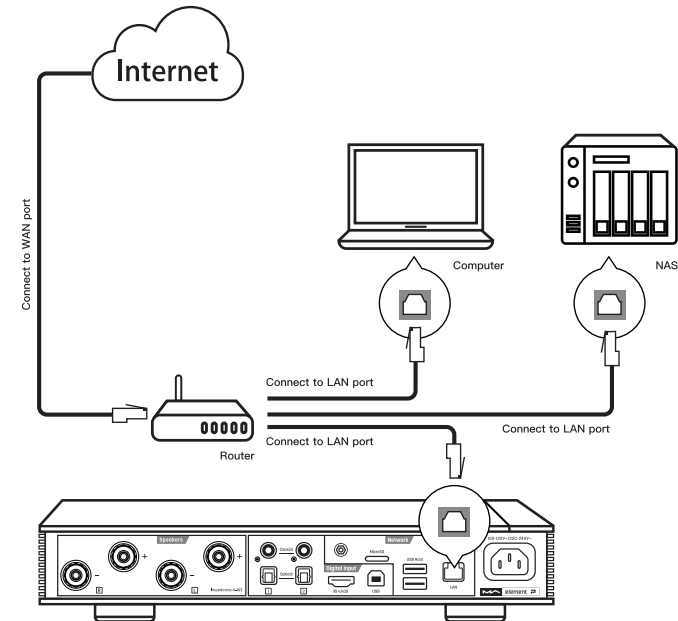

It is advisable to set up the router as DHCP server, and this function will allocate the device IP address in LAN automatically.

3.6 Connect to WLAN

3.6.1. Please make sure reliable installation of two Wi-Fi antennas on the rear panel (insert the Wi-Fi antenna into the jack and tighten it clockwise). You can adjust the antenna angle to change the signal effect.

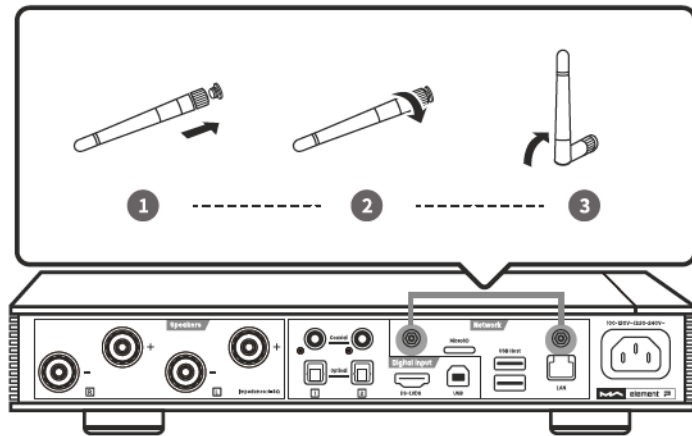

3.6.2. Let element P in the network status as shown below:

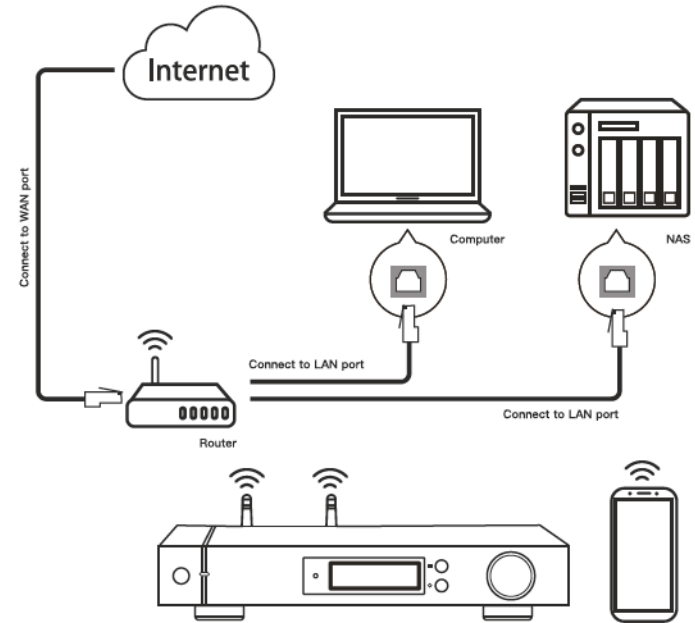

3.7.3. Scan QR code below to download MA Remote app, please run the app on your mobile device and follow the configuration wizard to set up the wireless network.



MA Remote APP

4. Play

4.1. Basic operation

4.1.1 Power on

The LED indicator will turn to dark white after element P connected to power supply, indicating that it enters the standby status, press the 'Standby' key on the unit body or remote control, element P will power on, and the LED indicator will turn to highlight white.

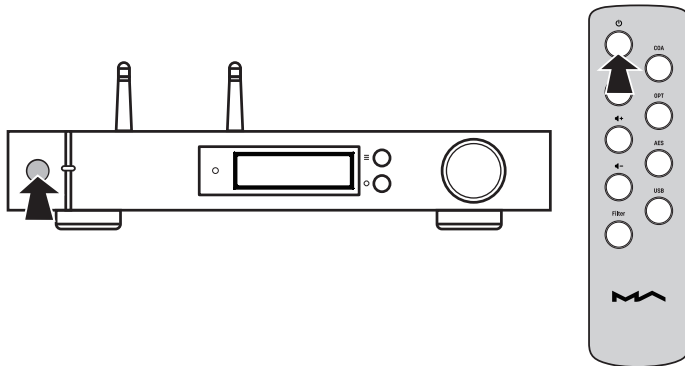

When element P is on, press the standby key for about 2 seconds to turn it into standby mode and the LED indicator will turn to dark white.

4.1.2 Select the input source

Repeat pressing the menu key '≡' and switch to channel option menu, then rotate the knob to select between auto, coaxial 1, coaxial 2, optical 1, optical 2, IIS LVDS, USB Audio and network, you can press the knob to affirm the channel.

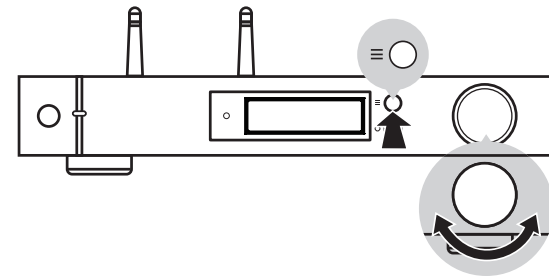

Under 'Auto' mode, element X will automatically scan all digital input channels, the first connected input channel will be locked immediately. It will continue to scan other channels until the current channel signal is lost. When there are several input channels being connected, element X is always locking the signal which is scanned at first. The order of input channel scanning is as shown,

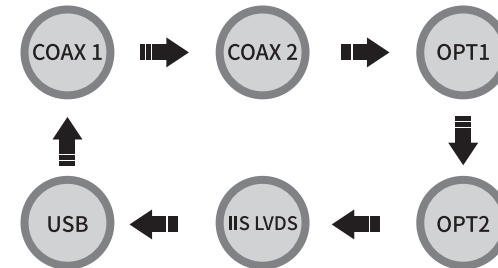

When selected 'Auto' channel and the input signal being locked, it will show the auto scan mark besides of the channel name. As shown,

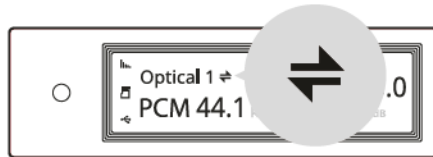

When using network related music source such as AirPlay, DLNA, ROON or MA player, please select Network input channel.

4.1.3 Volume control

4.1.3.1 Volume adjustment

The volume can be adjusted by the knob or the and key on the remote control, and the screen will show the current volume level at the same time. Line output and headphone output have independent volume control level, also, the line output can be configured as fixed level output.

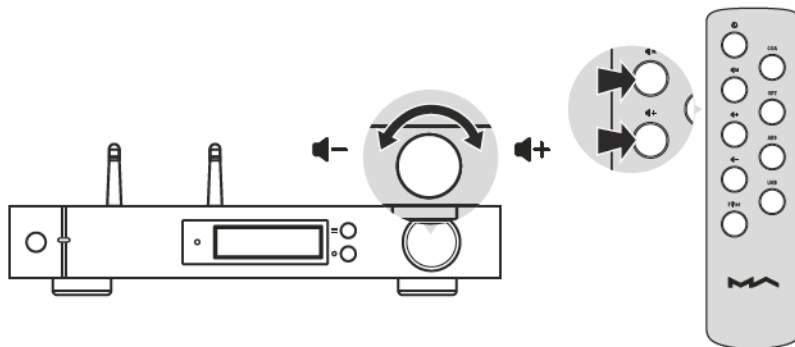

4.1.3.2 Mute

In playback status, you can press the volume knob or 'Mute' on the remote control to active mute; press the 'Mute' again or turn the volume knob to exit mute. There will be a mute icon on the screen when mute is activated.

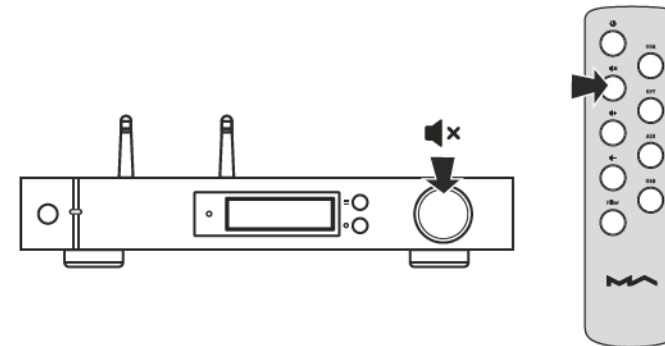

4.1.3.3 Hearing protection

In order to protect your hearing and avoid scaring by loud sound, when the volume level is higher than -20dB, the volume will be recovered to -20dB after reboot; if the volume level is lower than -20dB, it will return to the same volume as you set last time.

4.1.4 Filter settings

When element P is playing PCM or DSD music, users can select the digital filters to get different sound performance. Users can switch it on 1st and 2nd option in the setting menu or add the Filter setting to shortcut key 'O' on 9th option to fast switch it (page 13-14). The current selected filter will displayed in the auxiliary information area on the screen, and the encoding mode of the DSD audio is also displayed there.

When playing MQA files, the PCM filter will invalid.

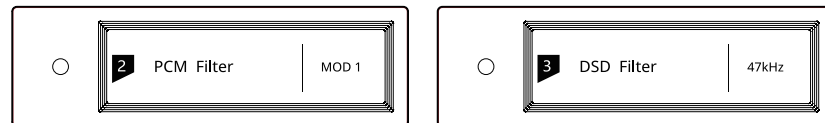

4.1.5 Auto sleep and wake up

element P will enter sleep mode when the current selected digital channel has no input signal and no operation for more than 5 minutes.

The following operations can wake up element P from sleep status,

- Press the volume knob on the front panel of element P
- Press the 'Standby' button on element P or remote control
- Recover the input signal of the selected channel or recover signal of any digital channels under Auto Scan mode

When element P stopped playing for more than 5 minutes on Network input channel, and no operation more than 5 minutes, it will enter sleep mode automatically, and will wake up by the following conditions:

- Push music to element P through AirPlay or DLNA
- Play music through MA player
- Play music as a ROON endpointv

4.1.6 Remote control

Remote control uses a CR2032 button cell battery. Pull out the battery slot at the bottom to install battery and make sure to put in the right polarity.

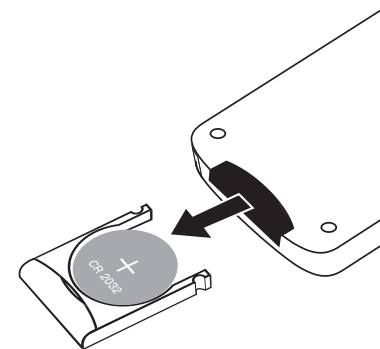

Please let the remote control point to the remote sensor among the area in the following picture, the remote distance is about 8 meters and the battery life is about one year, please change new battery if the remote distance become shorter or is not sensitive as before.

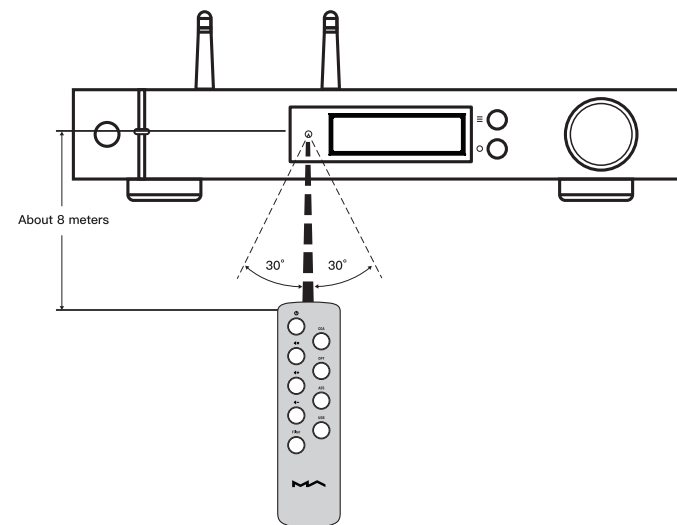

4.2 Play music through optical, coaxial or IIS-LVDS port

When it is connected with front-end devices, which including S/PDIF output digital signal through coaxial and optical port or Matrix digital audio interface products through IIS port, the screen will show sampling rate and signal format of the selected input channel.

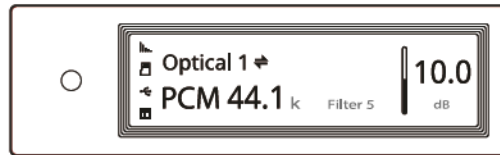

If the sampling rate and signal format on the screen is not displayed correctly, please check if the cable is reliable connected or the front-end devices is outputting signal.

4.3 Play music through AirPlay or DLNA

When the element P connected to the local area network, the mobile devices in the same network can push music to element P through AirPlay or DLNA.

Connect the Wi-Fi of your iPhone or iPad to the same local area network as the element P, and click AirPlay to select element P as audio device, then choose and enjoy your favored music.

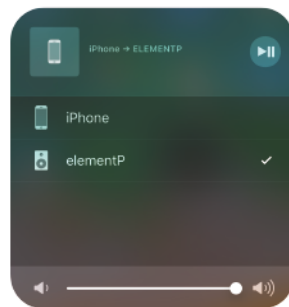

Connect the Android devices and element P through Wi-Fi under the same LAN, and open the APP including DLNA function, then play music and push it to element P.

The experience of using element P with an Android device is due to the compatibility of music APPs, not all the Android devices or music APPs have DLNA function.

4.4 Play music in USB storage devices\MicroSD Card\NAS

element P can play the music from USB storage devices\MicroSD Card\NAS through MA player. Download MA Remote APP to get more detail about user guide.

MA player can play kinds of lossless format audio files, as well as DSD music, it also includes an MQA full decoder technology, we believe you will feel a new experience when enjoying music collections.

4.5 USB Audio

When the element P need to be connected to computer as an USB DAC, please install driver for Windows 7/8/10 which can be found in Matrix official website, the URL of the download page is: <https://matrix-digi.com/en/downloads/>, the installation process as follow,

Install the Windows driver for element P

Step 1:

Double-click the driver installation file, and click 'Next'

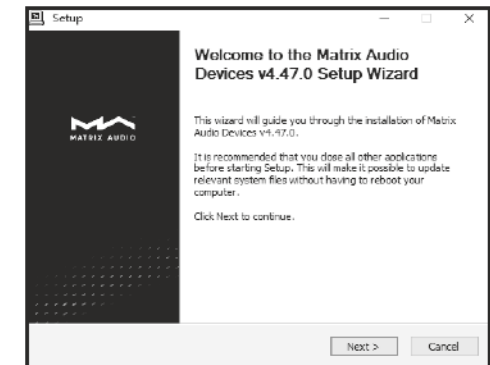

Step 2:
Please select the installation path and click 'Install'

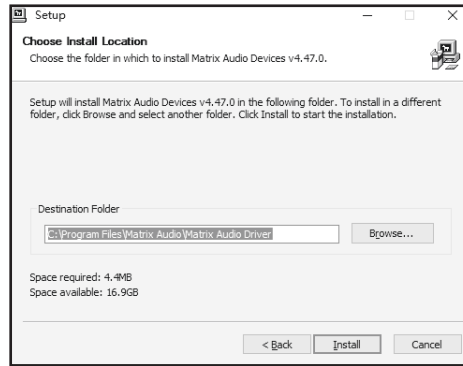

Step 3:
Installation is completed and click 'Next'

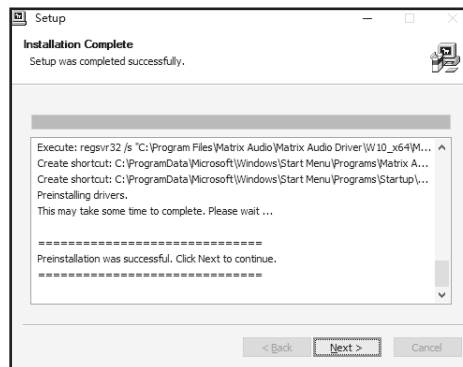

Step 4:
Click 'Finish', the driver installation is completed.

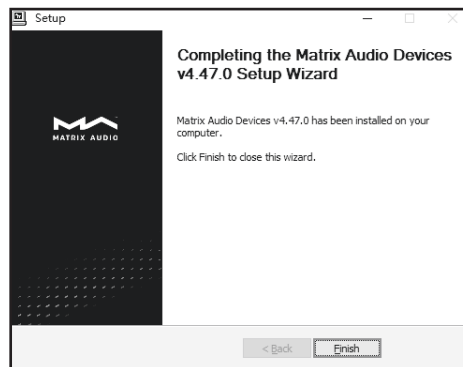

Use element P under Mac OS X

Mac OS X do not need driver. Please select the audio device as 'element Series' in System Preferences.



Connect element P to mobile devices via USB port

Use Apple Lightening to USB Camera Kits to connect element P with iOS devices. element P can be connected to an Android device with Micro USB or Type-C USB port via the OTG cable, but it's not guaranteed to be compatible with all the Android devices.

5. Settings

Repeat pressing the 'Menu' key to enter configuration menu, then press the knob to enter configuration items.

As shown:

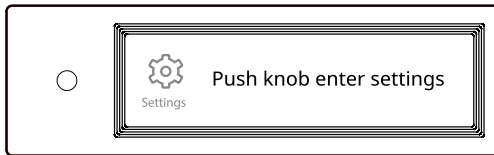

There are 13 items in the configuration menu as follow:

5.1 PCM Filters

Configurable 7 digital filters with different frequency response curves, to set filters for different timbre

MOD1 fast roll-off, minimum phase filter (Default)

MOD2 slow roll-off, minimum phase filter

MOD3 fast roll-off, linear phase filter

MOD4 slow roll-off, linear phase filter

MOD5 brickwall filter

MOD6 hybrid, fast roll-off, minimum phase filter

MOD7 Apodizing, fast roll-off, linear phase filter

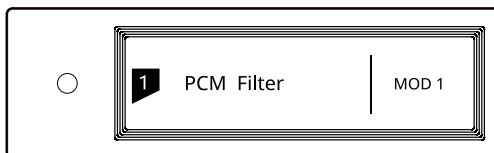

The frequency response curve of 7 different filters are as follow:

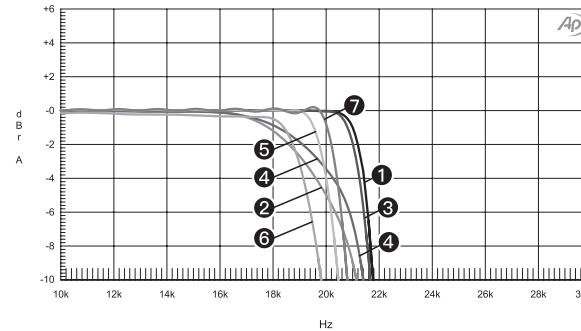

Sweep	Trace	Line Style	Thick	Data	Axis	Comment
1	1	Solid	1	DSP Anlr.Level A	Left	mod1_fast roll-off,minimum ①
2	1	Solid	1	DSP Anlr.Level A	Left	mod2_slow roll-off,minimum ②
3	1	Solid	1	DSP Anlr.Level A	Left	mod3_fast roll-off,linear ③
4	1	Solid	1	DSP Anlr.Level A	Left	mod4_slow roll-off,linear ④
5	1	Solid	1	DSP Anlr.Level A	Left	mod5_brickwall ⑤
6	1	Solid	1	DSP Anlr.Level A	Left	mod6_hybrid ⑥
7	1	Solid	1	DSP Anlr.Level A	Left	mod7_apodizing ⑦

(Tested at 1kHz)

5.2 DSD Filters

Set the cut-off frequency of DSD digital filter

47kHz (Default), 50kHz, 60kHz, 70kHz, AUTO

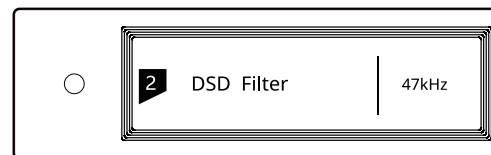

Suggestion:

DSD64 - 47k, DSD128 - 50k, and so on. When this option sets to AUTO, the DSD filter will be selected automatically.

5.3 Dither

Configure to turn ON/OFF the dither function, it can effectively reduce the quantizing distortion.

ON (Default)

OFF

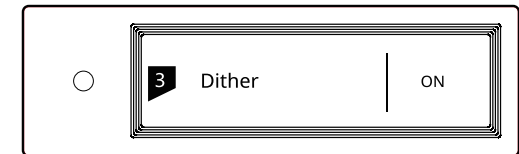

5.4 Jitter Eliminator

Set the internal time-base jitter elimination circuit for turn ON or OFF.

ON (Default)

OFF

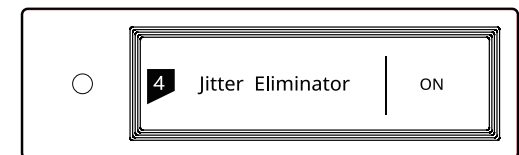

5.5 DPLL Bandwidth

Set the DPLL Bandwidth

Low: Low bandwidth High: High bandwidth

Normal: Standard bandwidth (Default)

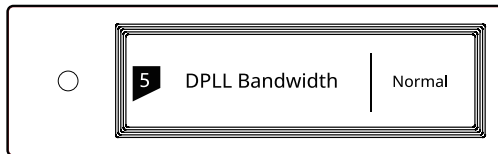

It's recommended to set the DPLL bandwidth to default, but when the quality of digital signal which output from front-end device is poor and the element P can not lock the signal stably, please select high bandwidth, while the sound quality may be reduced under high bandwidth mode.

5.6 IIS-LVDS Port Definition

There are 4 kinds of IIS-LVDS port definition for option, the different definitions are shown in the appendix,

TYPE A (Default)

TYPE B

TYPE C

TYPE D

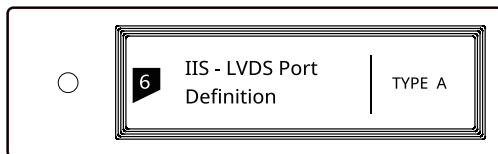

Please select 'TYPE A' when collocated with Matrix audio products.

5.7 Dimmer

In order to avoid the interference from the LED indicator and the screen, element P can enter dimmer mode after no operation for 5 minutes, when turn on this option. At dimmer mode, the LED indicator will reduce brightness and the screen will turn off. The screen can be activated by operating on the remote control or on the unit body. Turn off this option to prevent element P enter dimmer mode.

ON

OFF (Default)

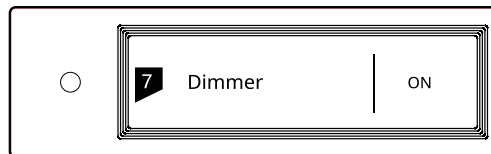

5.8 Auto Sleep

When there is no input signal from the selected channel and no operation for more than 5 minutes, element P will enter Sleep mode. element P will not enter 'Auto Sleep' mode when 'Auto Sleep' function is off.

ON

OFF (Default)

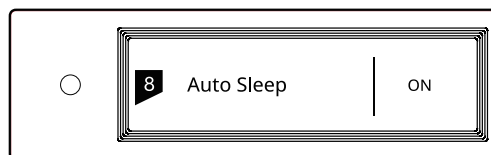

5.9 User defined button settings

Set the function of 'O' button on the front panel

There are three functions available:

INPUT (set as quick-switch input channels, every keystroke switch to another input channel)

OUTPUT (set as quick-switch output channels, every keystroke switch to another output channel)

FILTER (set as quick-switch filters, every keystroke switch to another filter)

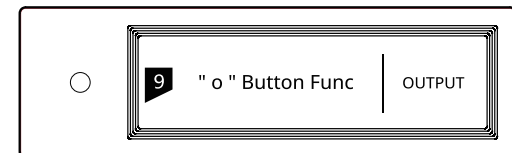

5.10 Network Type

Select network access method for element X, when you select the option LAN, Wi-Fi is disabled and vice versa if you select Wi-Fi, ethernet is disabled.

LAN: Wired network

Wi-Fi: Wireless network (Default)

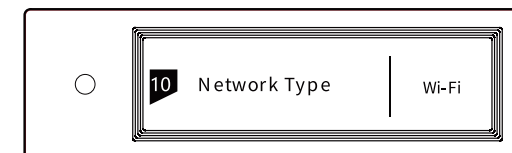

5.11 Remote Control

If there are more than 1 Matrix device in the same place, in order to prevent one remote control from controlling multiple device at the same time, element P has built-in 5 sets of remote control address codes, which can be switched under this option to achieve 'one-to-one' control between the remote control and the host.

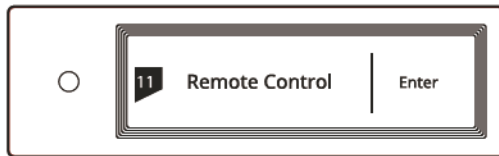

Press the knob to enter the remote control settings as shown below, at this time, you will see the current remote control address code on the screen, press the button on the remote control and the screen will display the corresponding name. Hold the Standby and Filter buttons on the remote control for 5 seconds at the same time, the screen will display a new address code, press the 2 buttons again within 5 seconds to switch to the next address code, repeat the operations above to select the address code, press '≡' or 'O' to return to the menu page.

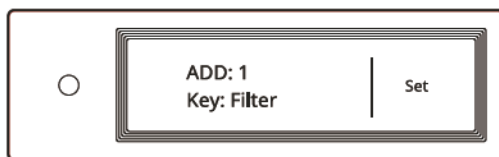

5.12 Load Default

Press the knob in this option, all the settings will return to default.

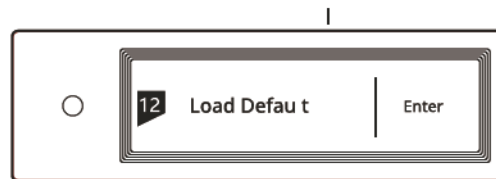

5.13 Product information

Push the knob under this option, the hardware and software information will shown on the screen.



6. Appendix

6.1 Audio file formats and sampling rate supported

MA player supports the following audio file formats:

MP3, WMA, WAV, AIF, AIFC, AIFF, AAC, FLAC, OGG, APE, ALAC, M4A, DSF, DFF

PCM sampling rate support up to:

PCM 16/24/32Bit 44.1kHz, 48kHz, 88.2kHz, 96kHz, 176.4kHz, 192kHz, 352.8kHz, 384kHz, 705.6kHz, 768kHz

DSD sampling rate support up to:

DSD 2.8 MHz, 5.6 MHz, 11.2 MHz, 22.4MHz

More audio file formats could be supported through future firmware updates.

6.2 About MQA (Master Quality Authenticated)

MQA is an award-winning British technology that delivers the sound of the original master recording. The master MQA file is fully authenticated and is small enough to stream or download.

'MQA' or 'MQA.' indicates that the product is decoding and playing an MQA stream or file, and denotes provenance to ensure that the sound is identical to that of the source material.

'MQA.' indicates it is playing an MQA Studio file, which has either been approved in the studio by the artist/producer or has been verified by the copyright

owner. The MA player delivers the final unfold of the MQA file and displays the original sample rate of the file. The sampling rate for MQA encoded playback covers 44.1k-384kHz.

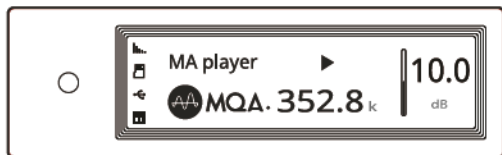

6.3 USB storage device requirements

- element P can use devices that comply with the USB mass storage standard, but cannot guarantee compatibility with all storage devices or memory cards.
- USB storage devices support FAT, FAT32, exFAT, NTFS formats.
- If the USB storage device is partitioned, each partition will be treated as a separated device.
- When using extension cable to connect a USB storage device may result in unstable connection.
- When using a USB hub to connect the USB storage device to element P, it may not work properly.
- The USB port of element P cannot supply more than 500 mA to the peripherals.
- If USB storage device comes with a power adapter, please connect power adapter to the storage device.

CAUTION:

Matrix Audio is not responsible for data loss, modification, or failure to the USB storage devices. We strongly recommend you back up the data in the USB storage device before using it on element P.

6.4 IIS-LVDS Port

The IIS port of element P is a standard 19-pin HDMI connector. It uses four sets of LVDS differential signals to transmit IIS data. It supports up to 32Bit/768kHz PCM signal input and 1Bit/45.1MHz DSD signal input. The PCM format is the standard IIS format, the DSD format supports the original DSD format (Native DSD) and DoP (DSD over PCM) encoding.

The IIS port of element P could be defined as TYPE A, B, C and D, which can be configured in the setting menu.

The port definition as shown below:

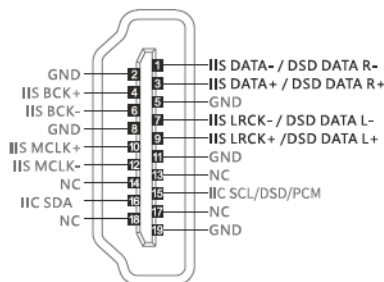

TYPE A:
IIS standard definition

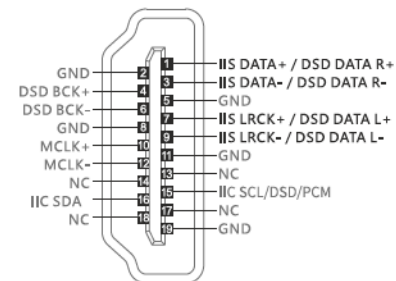

TYPE B:
IIS reverse definition

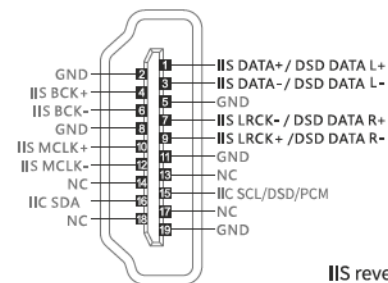

TYPE C:
IIS reverse definition

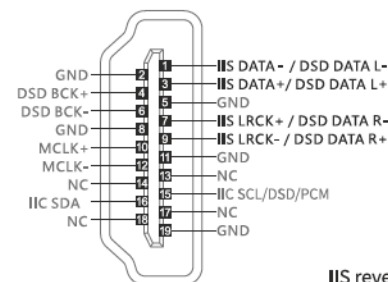

TYPE D:
IIS reverse definition

6.5 Technical Specifications

Digital Input

Coaxial and optical:

PCM 16-24Bit/44.1kHz, 48kHz, 88.2kHz, 96kHz,
176.4kHz, 192kHz

DSD DSD64(DoP)

IIS-LVDS:

PCM 16-32Bit /44.1kHz, 48kHz, 88.2kHz, 96kHz
176.4kHz, 192kHz, 352.8kHz, 384kHz,
705.6kHz, 768kHz

DSD DSD64/128/256/(DoP)

DSD DSD64/128/256/512/1024(Native)

USB audio:

PCM 16-24Bit /44.1kHz, 48kHz, 88.2kHz, 96kHz,
176.4kHz, 192kHz, 352.8kHz, 384kHz,
705.6kHz, 768kHz

DSD DSD64/128/256(DoP)

DSD DSD64/128/256/512(Native)

Speaker output

SNR: >-121dB

THD+N: <0.008% @1W (8Ω, 1kHz)

Frequency response: 20Hz-20kHz ±0.25 -3dB@85kHz

Output impedance: <25mΩ

Output power: 230W@4Ω, 110W@8Ω (1%THD+N)

Gain: +40dB

Network

LAN: 10BASE-T/100BASE-TX

WLAN: 2.4GHz/5GHz, IEEE 802.11 a/b/g/n/ac standard

Power Supply

Power voltage:

230V position is fit for AC220V-240V 50/60Hz

115V position is fit for AC100V-120V 50/60Hz

Standby power consumption: < 1W

Sleep power consumption: < 4W

Non-playing power consumption: <22W

Dimension

340×281×60mm

(L×W×H, including the protruding part)

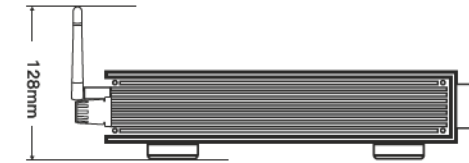
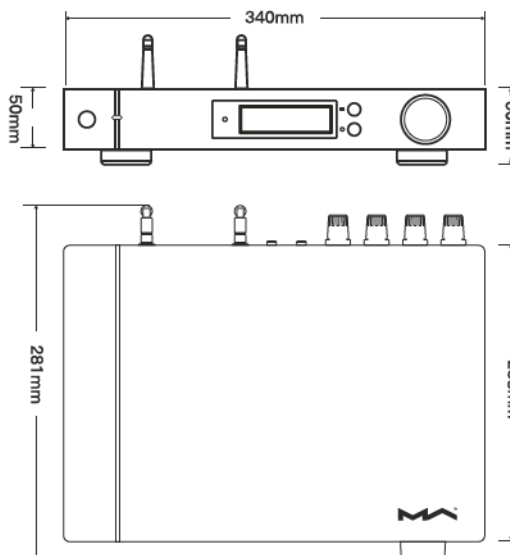

Weight

4.5kg

For improvement purpose, specifications subject to changes without prior notice.

The product with Hi-Res Audio logo is conformed to High-Resolution Audio standard defined by Japan Audio Society. This logo is used under license from Japan Audio Society.

The MQA logo is a trade mark of MQA Limited.

© MQA Limited 2018.