

**element · M**

---

# **MUSIC STREAMER COMBO**

## **User Manual**

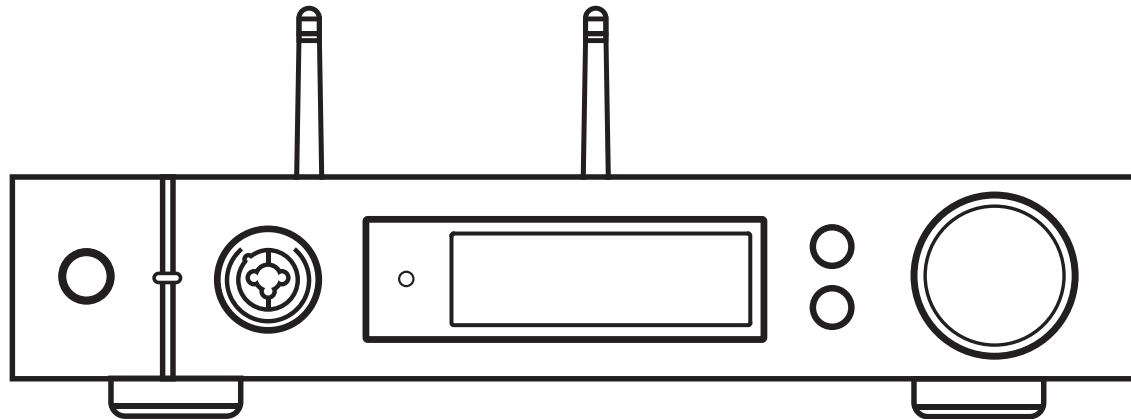

# HIGH PERFORMANCE AUDIO

[www.matrix-digi.com](http://www.matrix-digi.com)

Matrix Electronic Technology Co., Ltd.  
+86-29-86211122  
B-801, No.111 Fengcheng 5th Rd.,  
Xi'an, China  
[support@matrix-digi.com](mailto:support@matrix-digi.com)



## Catalog

<b>1. Packing list</b>	01	<b>4.1.2 Select the input source</b>	08	<b>5.9 Auto Sleep</b>	14
<b>2. Parts and name</b>	01	<b>4.1.3 Select output channel</b>	08	<b>5.10 User Defined Button Settings</b>	14
2.1 Front panel	01	<b>4.1.4 Volume control</b>	08	<b>5.11 Network Type</b>	14
2.2 Rear panel	02	4.1.4.1 Volume adjustment	08	<b>5.12 Remote Control</b>	14
2.3 Display screen	02	4.1.4.2 Mute	09	<b>5.13 Load Default</b>	15
2.3.1 Display in main interface area	02	4.1.4.3 Hearing protection	09	<b>5.14 Product Information</b>	15
2.3.2 Volume control	02	<b>4.1.5 Gain control</b>	09	<b>6. Appendix</b>	15
2.3.3 Display for input channel	03	4.1.6 Auto sleep and wake up	09	6.1 File formats and sampling rate supported	15
2.3.4 Display for Output channel	03	<b>4.1.7 Remote control</b>	10	6.2 About MQA	15
2.4 Remote control	03	<b>4.2 Play music through optical, coaxial or IIS-LVDS port</b>	10	6.3 USB storage device requirements	16
<b>3. Connections</b>	04	<b>4.3 Play music through AirPlay or DLNA</b>	10	6.4 IIS-LVDS Port	16
3.1 Connect to AC power	04	<b>4.4 Play music in USB storage devices\SD Card\NAS</b>	10	6.5 Technical specifications	16
3.2 Connect to input source	05	<b>4.5 USB Audio</b>	11		
3.3 Connect to headphone	05	<b>5. Settings</b>	12		
3.4 Connect to active speaker or AMP	05	5.1 Lineout Mode	12		
3.5 Connect to storage devices	06	5.2 PCM Filters	13		
3.6 Connect to LAN	06	5.3 DSD Filters	13		
3.7 Connect to WLAN	07	5.4 Dither	13		
<b>4. Play</b>	07	5.5 Jitter Eliminator	13		
4.1 Basic operation	07	5.6 DPLL Bandwidth	13		
4.1.1 Power on	07	<b>5.7 IIS-LVDS Port Definition</b>	14		
		<b>5.8 Dimmer</b>	14		

## 1. Packing list

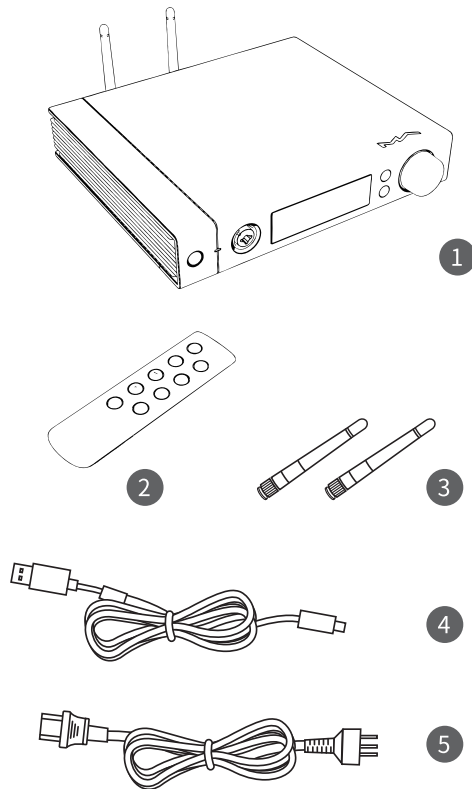

- 1. Product ×1
- 2. Remote ×1
- 3. Wi-Fi antenna ×2
- 4. USB cable ×1
- 5. Power cable ×1

## 2. Parts and name

### 2.1 Front panel

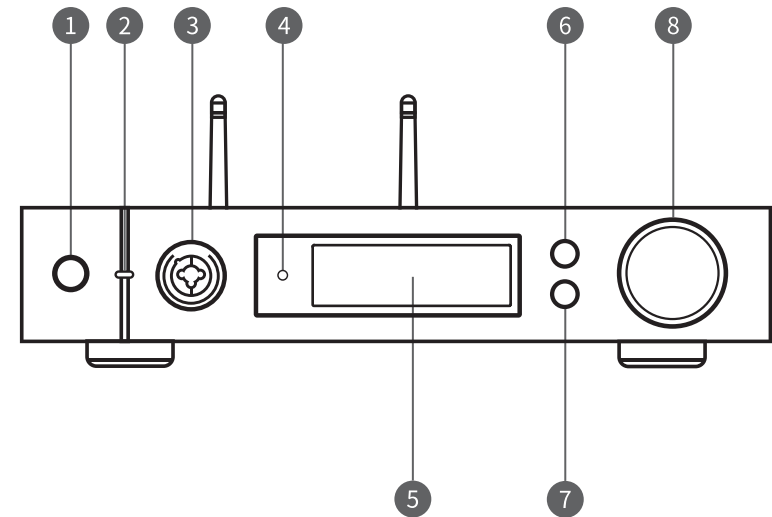

- 1. Standby
- 2. LED indicator
- 3. XLR3/6.35mm headphone jack
- 4. Remote control sensor
- 5. Display
- 6. Menu
- 7. User-defined
- 8. Volume/control knob

## 2.2 Rear panel

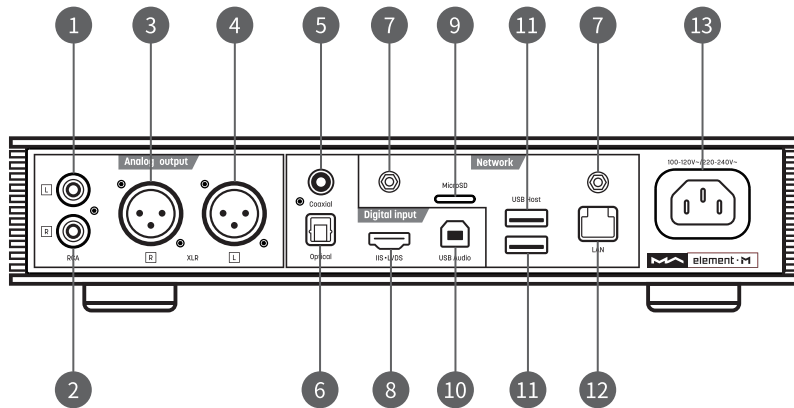

- |                             |                        |
|-----------------------------|------------------------|
| 1. RCA left channel output  | 8. IIS LVDS input      |
| 2. RCA right channel output | 9. MicroSD card slot   |
| 3. XLR right channel output | 10. USB Audio port     |
| 4. XLR left channel output  | 11. USB Host port      |
| 5. Coaxial input            | 12. Wired network port |
| 6. Optical input            | 13. Power input        |
| 7. Wi-Fi antenna jack       |                        |

## 2.3 Display screen

### 2.3.1 Display in main interface area

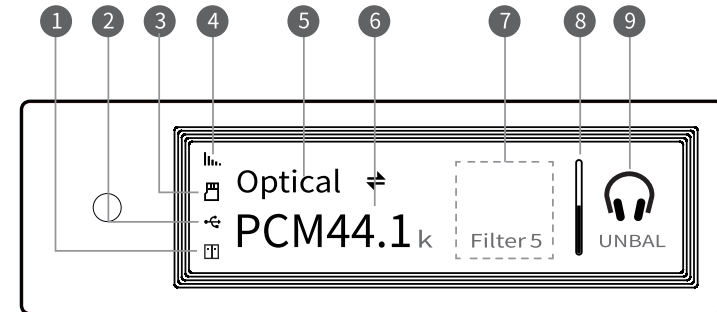

- |   |                          |
|---|--------------------------|
| 1. Status for NAS devices                   | 5. Input channel         |
| 2. Status for USB storage devices           | 6. Sampling rate         |
| 3. Status for MicroSD card                  | 7. Assistant information |
| 4. Status for Wi-Fi and ethernet connection | 8. Volume bar            |
|   | 9. Output mode           |

### 2.3.2 Volume control

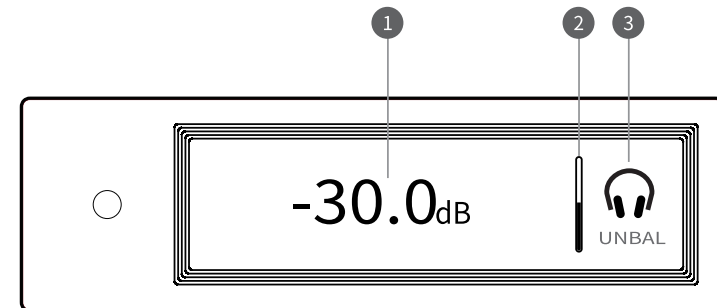

- |                            |               |                |
|----------------------------|---------------|----------------|
| 1. Current volume dB level | 2. Volume bar | 3. Output mode |
|----------------------------|---------------|----------------|

2.3.3 Display for input channel

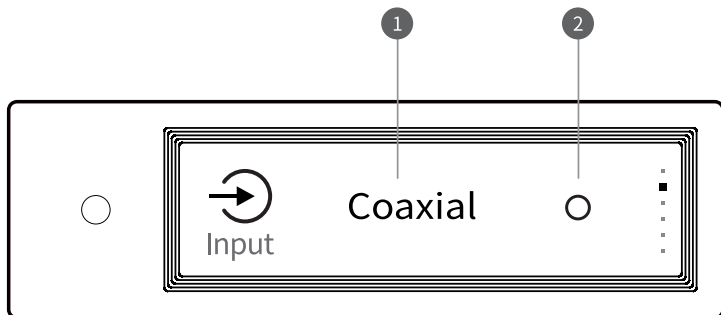

- 1. Input channel
- 2. Unselected

2.3.4 Display for output channel

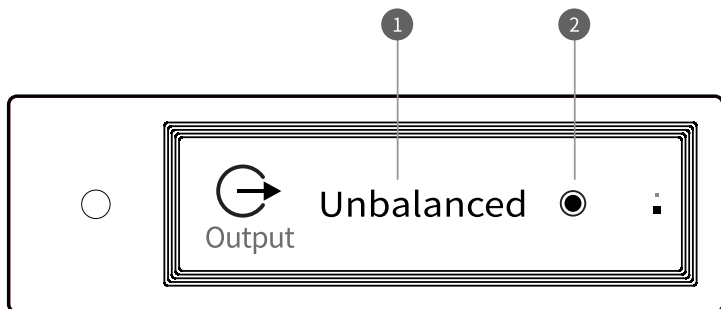

- 1. Current output mode
- 2. Selected

2.4 Remote control

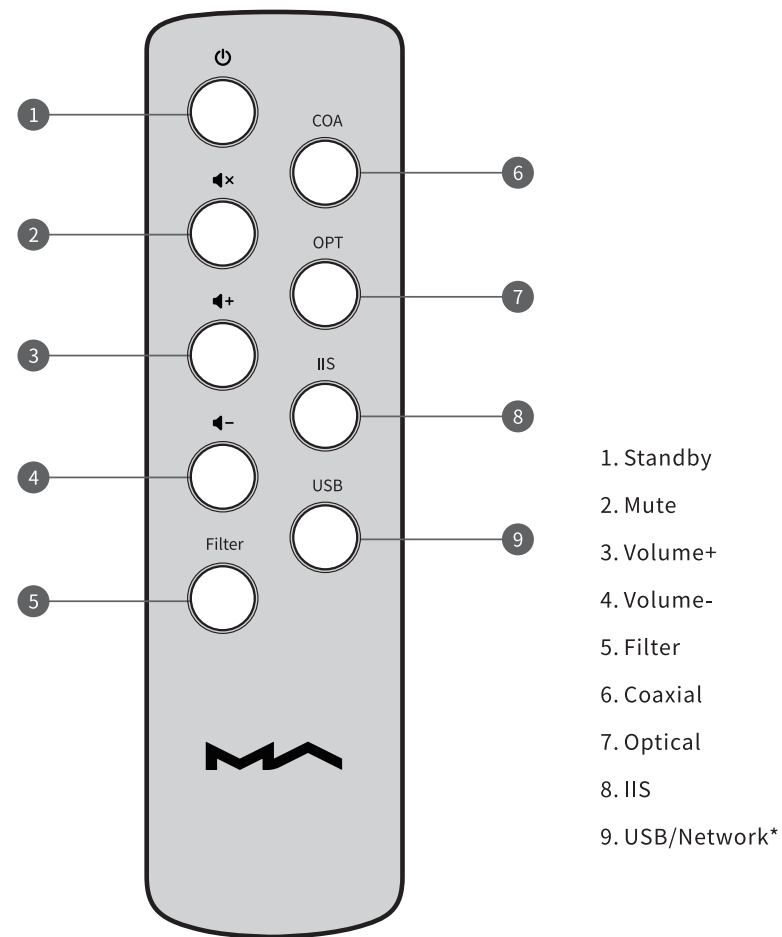

\*This button can switch input channels between USB and Network.

## 3. Connections

### 3.1 Connect to AC power

element M is compatible with AC100-120V and AC220-240V power specifications.

Please make sure to switch the bottom power voltage according to your local voltage environment before using. As shown:

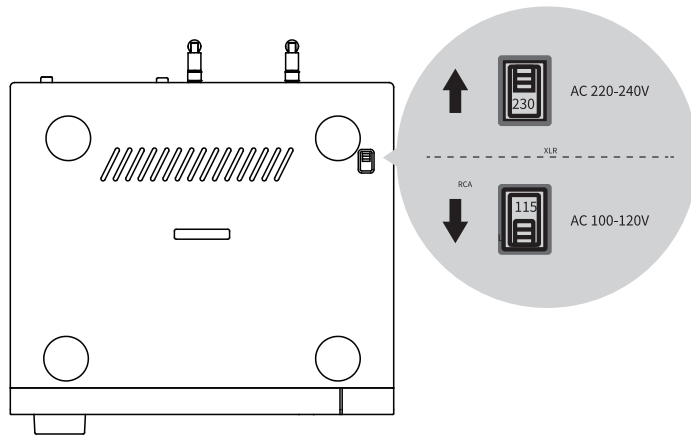

Please use three-phase power cable which includes the ground terminal and ensure the ground is reliably connected, or you will have a sense of electric shock when you touch it.

Please unplug the power cable if you need the element M is disconnected the power thoroughly.

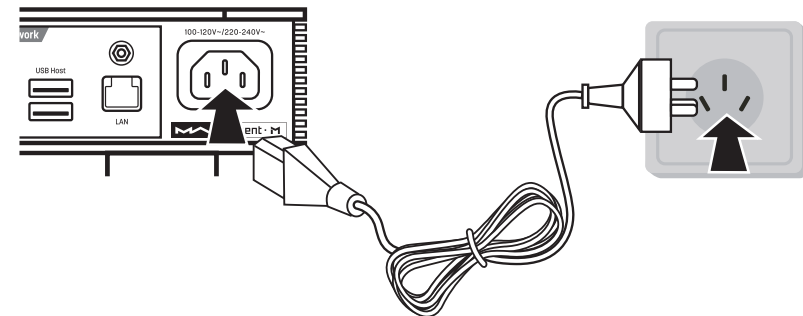

The two sections of the voltage switch are 115V and 230V, each section for:

115V position is fit for AC100V-120V 50/60Hz

230V position is fit for AC220V-240V 50/60Hz

### 3.2 Connect to input source

Connection for front-end devices including S/PDIF output signal through coaxial and optical port;

Connection for digital interface products of Matrix through IIS port

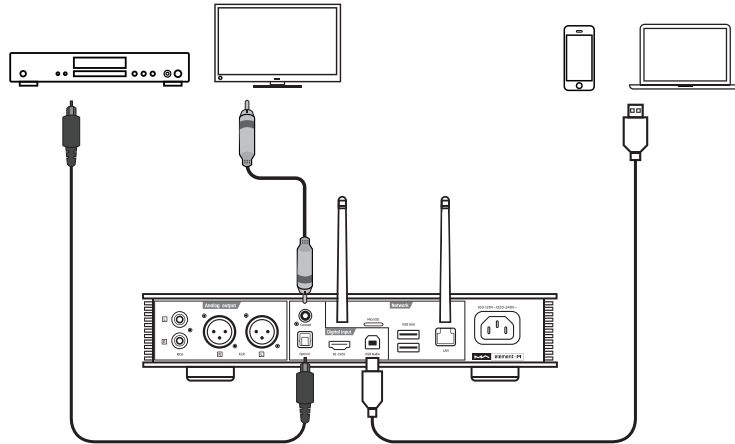

### 3.3 Connect headphones

There is a hybrid headphone jack on the front panel of element M. You can connect 2 kinds of headphones as shown below:

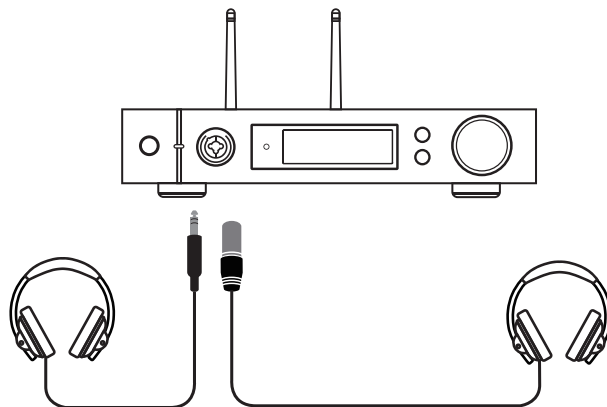

### 3.4 Connect to active speakers or AMPs

In order to avoid damage to your devices, please turn off the active speakers or amplifiers before you connect them to element M.

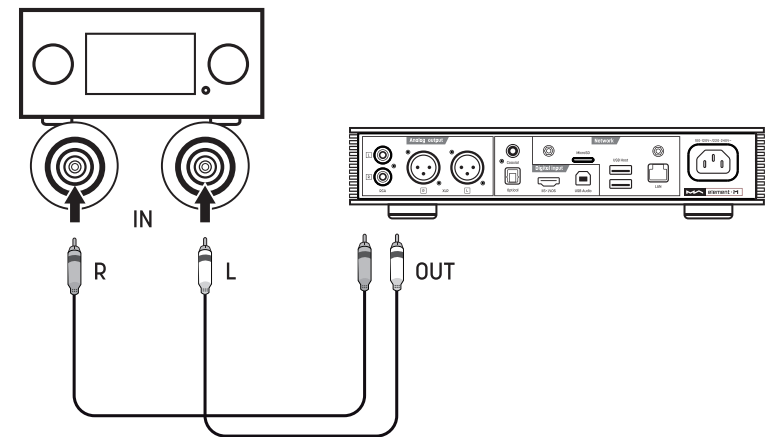
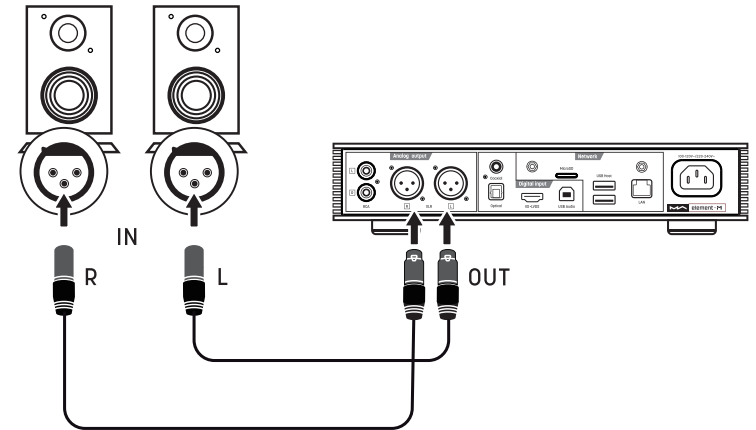



### 3.5 Connect to storage devices

There are two USB HOST ports on the rear panel to connect with standard mass storage USB devices.

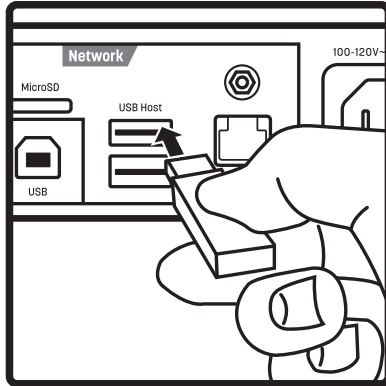

The MicroSD card support up to 128GB, push to install or popup the card.

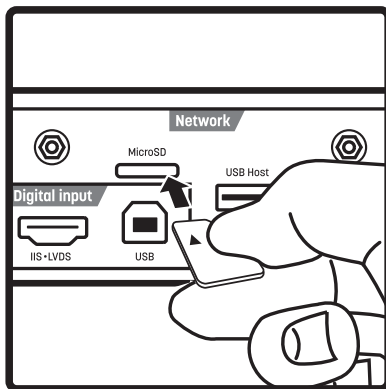

### 3.6 Connect to LAN

Please use ethernet cable to connect element M to your network router (recommend using CAT-5 or higher version shield ethernet cable), and let element M in the status as shown below:

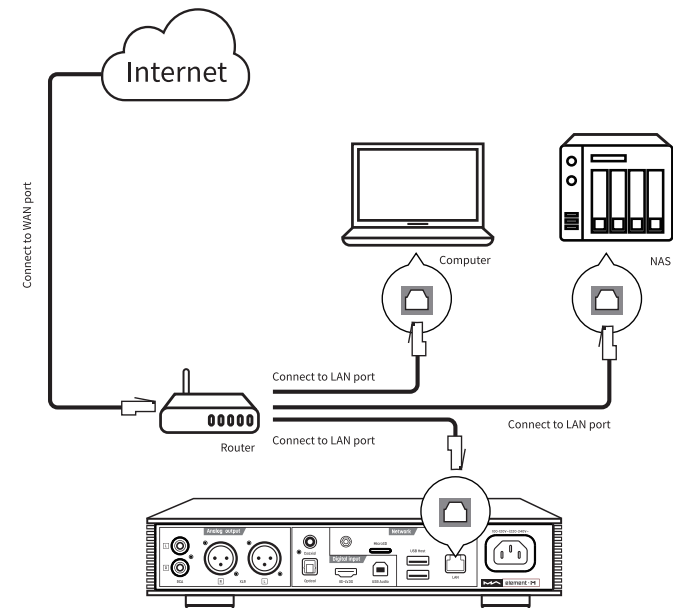

It is advisable to set up the router as DHCP server, and this function will allocate the device IP address in LAN automatically.

### 3.7 Connect to WLAN

3.7.1. Please install 2 Wi-Fi antennas on the rear panel reliably (plug the Wi-Fi antenna into the jack and tighten it clockwise). You can adjust the antenna angle to ensure signal reception is stable.

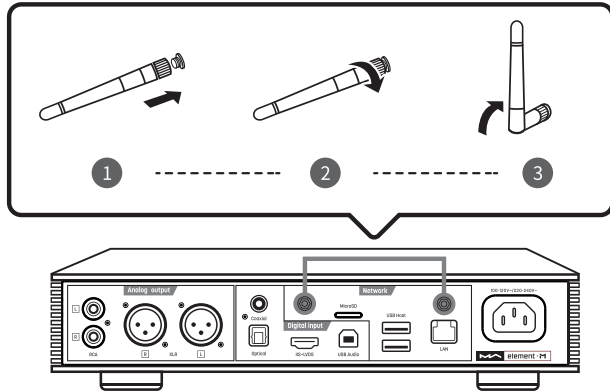

3.7.2. Let element M in the status as shown below:

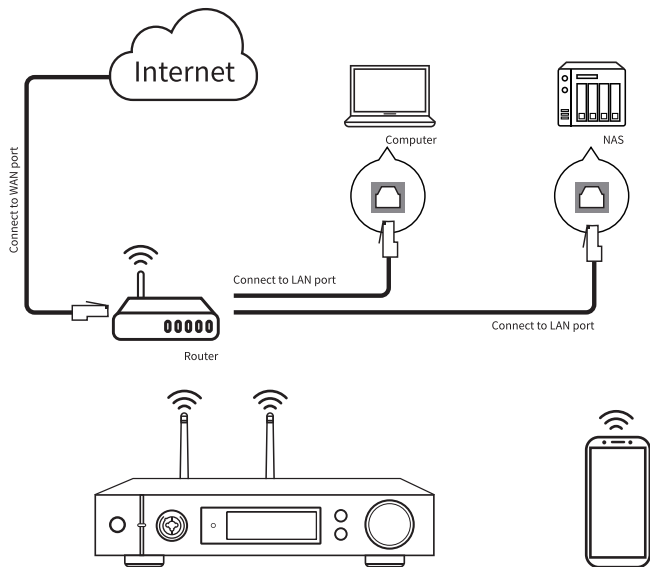

3.7.3. Scan QR code below to download MA Remote app, please run the app on your mobile device and follow the configuration wizard to set up the wireless network.



## 4. Play

### 4.1. Basic operation

#### 4.1.1 Power on

The LED indicator will turn to dark white after element M connected to power supply, indicating that it enters the standby status, press the 'Standby' button on the unit body or remote control, element M will power on, and the LED indicator will turn to highlight white.

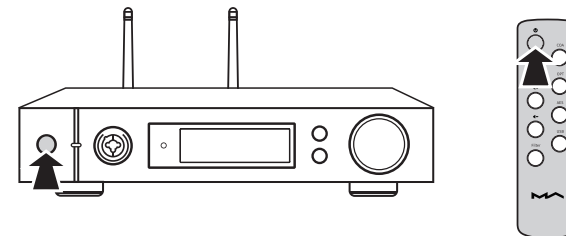

When element M is on, press the standby key for about 2 seconds to turn it into standby mode and the LED indicator will turn to dark white.

### 4.1.2 Select the input source

Press the menu button '≡' to switch to channel option menu, then rotate the knob to select between auto, coaxial, optical, IIS LVDS, USB Audio and network, you can press the knob to select the channel.

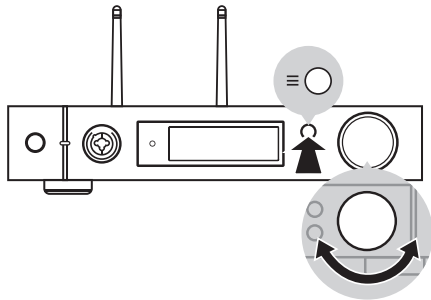

Under 'Auto' mode, element M will automatically scan all digital input channels, the first connected input channel will be locked immediately. It will continue to scan other channels until the current channel signal is lost. When there are several input channels being connected, element M is always locking the signal which is scanned at first. The order of input channel scanning is as shown,

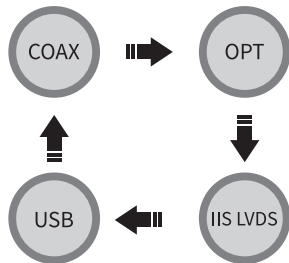

When the USB Audio function is closed, the auto scan will ignore USB channel. When selected 'Auto' channel and the input signal being locked, it will show the auto scan mark besides of the channel name. As shown,

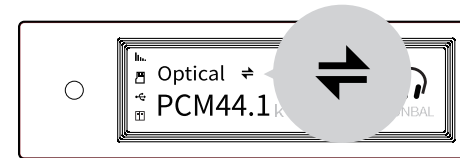

When using network related music source such as AirPlay, DLNA, ROON or MA player, please select Network input channel.

### 4.1.3 Select output channel

Press the 'O' button on the front panel to select output channel between single-ended headphone output and line output, then push the button for confirmation. The switching order is as follow,

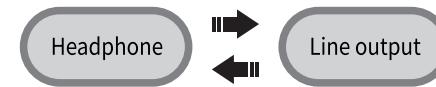

### 4.1.4 Volume control

#### 4.1.4.1 Volume adjustment

The volume can be adjusted by the knob ◀- or ▶+ the and key on the remote control, and the screen will show the current volume level at the same time. Line output and headphone output have independent volume control level, also, the line output can be configured as fixed level output.

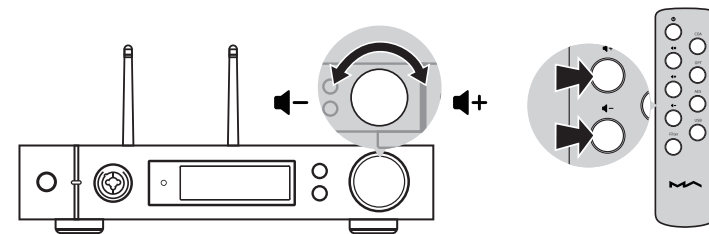

## CAUTION

'Fixed output' means that the device outputs signal with maximum level at 0dB. Before selecting this mode, please make sure that your power amplifier or active speaker has been adjusted to a lower volume level. If the amplifier or speakers do not have volume control, DO NOT set up to 'Fixed output' mode, otherwise this operation may damage to your devices and harm to your ears.

### 4.1.4.2 Mute

In playback status, you can press the volume knob or 'Mute' on the remote control to active mute; press the 'Mute' again or turn the volume knob to exit mute. There will be a mute icon on the screen when mute is activated.

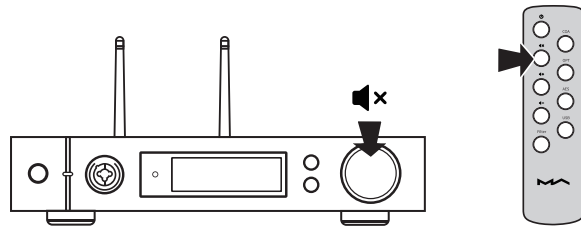

### 4.1.4.3 Hearing protection

In order to protect your hearing and avoid scaring by loud sound, when the volume level of single-ended headphone is higher than -30dB, the volume will be recovered to -30dB after element M reboot; if the volume is lower than -30dB, it will return to the same volume level as you set last time.

### 4.1.5 Filter settings

When element M is playing PCM or DSD music, users can select the digital filters to get different sound performance. Users can switch it on 2nd option in the setting menu or add the Filter setting to shortcut key 'O' on 10th option to fast switch it. The current selected filter will displayed in the assistant information area on the screen, and the encoding mode of the DSD audio is also displayed there.

When playing MQA files, the PCM filter will invalid.

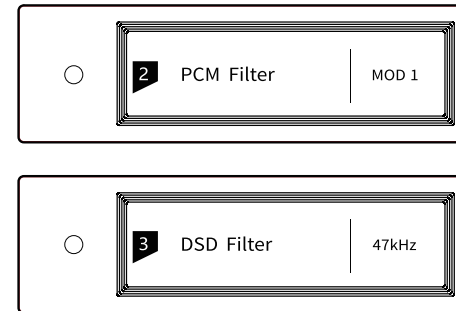

### 4.1.6 Auto sleep and wake up

element M will enter sleep mode when the current selected digital channel has no input signal and no operation for more than 5 minutes.

The following operations can wake up element M from sleep status,

- Press the volume knob on the front panel of element M
- Press the 'Standby' button on element M or remote control
- Recover the input signal of the selected channel or recover signal of any digital channels under Auto Scan mode

When element M stopped playing for more than 5 minutes on Network input channel, and no operation more than 5 minutes, it will enter sleep mode automatically, and will wake up by the following conditions:

- Push music to element M through AirPlay or DLNA
- Play music through MA player
- Play music as a ROON endpoint

### 4.1.7 Remote control

Remote control uses a CR2032 button cell battery. Pull out the battery slot at the bottom to install battery and make sure to put in the right polarity.

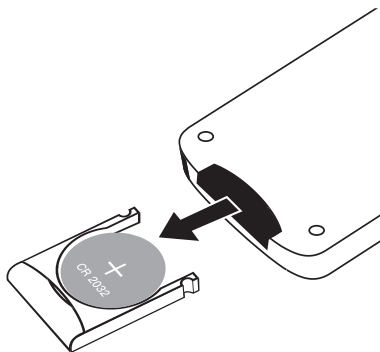

Please let the remote control point to the remote sensor among the area in the following picture, the remote distance is about 8 meters and the battery life is about one year, please change new battery if the remote distance become shorter or is not sensitive as before.

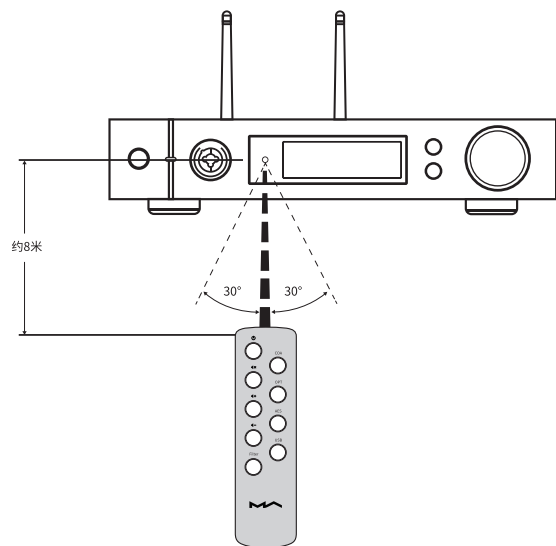

### 4.2 Play music through optical, coaxial or IIS-LVDS port

When it is connected with front-end devices, which including S/PDIF output digital signal through coaxial and optical port or digital interface products of Matrix Audio through IIS port, the screen will show sampling rate and signal format of the selected input channel.

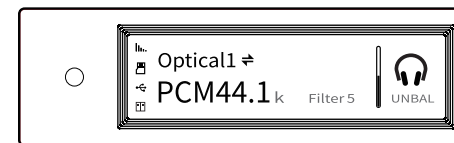

If the sampling rate and signal format on the screen is not displayed correctly, please check if the cable is reliable connected or the front-end devices is outputting signal.

### 4.3 Play music in USB storage devices\MicroSD Card\NAS

element M can play the music from USB storage devices\MicroSD Card\NAS through MA player. Download MA Remote APP to get more detail about user guide.

MA player can play kinds of lossless format audio files, as well as DSD music, it also includes an MQA full decoder technology, we believe you will feel a new experience when enjoying music collections.

### 4.4 Play music through AirPlay or DLNA

After element M connected to LAN with the ethernet cable or wireless, users can push the music from your smart phone or other mobile devices to it through AirPlay or DLNA.

Connect the Wi-Fi of your iPhone or iPad to the same local area network as the element M, and click AirPlay to select element M as audio device, then choose and enjoy your favored music.

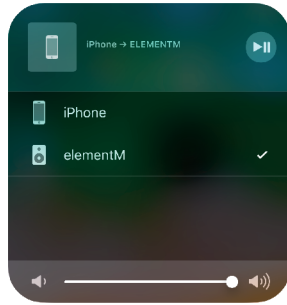

Connect the Android devices and element M through Wi-Fi under the same LAN, and open the APP including DLNA function, then play music and push it to element M.

The experience of using element M with an Android device is due to the compatibility of music APPs, not all the Android devices or music APPs have DLNA function.

### 4.5 USB Audio

When the element M need to be connected to computer as an USB DAC, please install driver for Windows 7/8/10 which can be found in Matrix official website, the URL of the download page is:

<https://matrix-digi.com/en/downloads/>, the installation process as follow,

### Install the Windows driver for element M

Step 1:  
Double-click the driver installation file, and click 'Next'

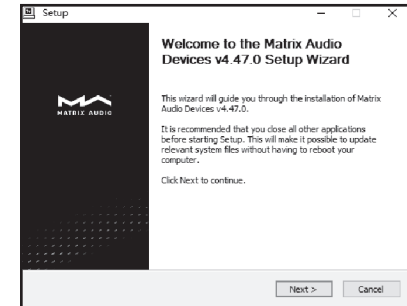

Step 2:  
Please select the installation path and click 'Install'

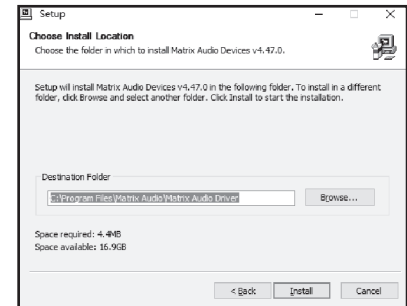

Step 3:  
Installation is completed and click 'Next'

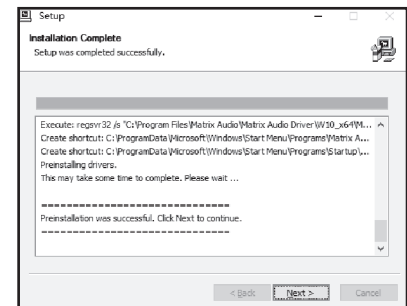

Step 4:  
Click 'Finish', the driver installation is completed.



Use element M under Mac OS X

Mac OS X do not need driver. Please select the audio device as 'element Series' in System Preferences.



Connect element M to mobile devices via USB port

Use Apple Lightning to USB Camera Kits to connect element M with iOS devices.

element M can be connected to an Android device with Micro USB or Type-C USB port via the OTG cable, but it's not guaranteed to be compatible with all the Android devices.

## 5. Settings

Repeat pressing the 'Menu' key to enter into configuration menu, then press the knob to enter configuration items.

As shown:

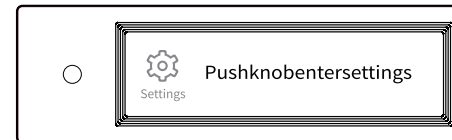

There are 14 items in the configuration menu as follow:

### 5.1 Lineout Mode

Lineout mode can be set as,

0dB Fixed: 0dB gain , fixed

0dB ADJ: 0dB gain, attenuation adjustable ( Default)

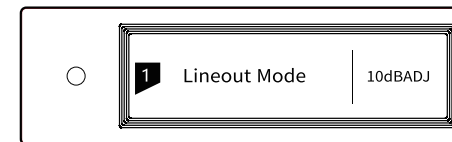

Connect to active speakers, recommend to set as '0dB ADJ' .

Connect to power amplifier including volume control, recommend to set as '0dB Fixed' .

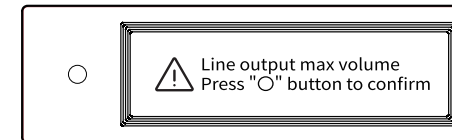

In order to avoid misoperation, switching from 0dB ADJ to 0dB Fixed need 2-step confirmation, press "O" button to confirm, other operations will cancel this setting.

### 5.2 PCM Filters

There are 7 kinds of digital filters with different frequency response curves built-in, to set filters for different timbre

- MOD1 fast roll-off, minimum phase filter (Default)
- MOD2 slow roll-off, minimum phase filter
- MOD3 fast roll-off, linear phase filter
- MOD4 slow roll-off, linear phase filter
- MOD5 brickwall filter
- MOD6 hybrid, fast roll-off, minimum phase filter
- MOD7 Apodizing, fast roll-off, linear phase filter

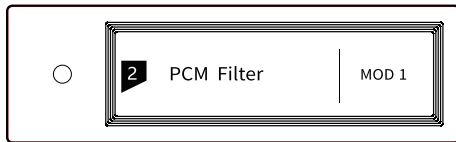

The frequency response curve of 7 different filters are as follow:

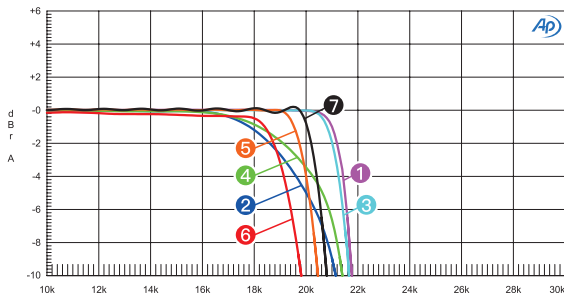

Sweep	Trace	Line Style	Thick	Data	Axis	Comment
1	1	Solid	1	DSP Anlr.Level A	Left	mod1_fast roll-off_minimum
2	1	Solid	1	DSP Anlr.Level A	Left	mod2_slow roll-off_minimum
3	1	Solid	1	DSP Anlr.Level A	Left	mod3_fast roll-off_linear
4	1	Solid	1	DSP Anlr.Level A	Left	mod4_slow roll-off_linear
5	1	Solid	1	DSP Anlr.Level A	Left	mod5_brickwall
6	1	Solid	1	DSP Anlr.Level A	Left	mod6_hybrid
7	1	Solid	1	DSP Anlr.Level A	Left	mod7_apodizing

(Tested at 44.1kHz)

### 5.3 DSD Filters

Set the cut-off frequency of DSD digital filter 47kHz (Default), 50kHz, 60kHz, 70kHz, AUTO



Suggestion:

DSD64 - 47k, DSD128 - 50k, and so on. When this option sets to AUTO, the DSD filter will be selected automatically.

### 5.4 Dither

Configure to turn ON/OFF the dither function, it can effectively reduce the quantizing distortion.

- ON (Default)
- OFF

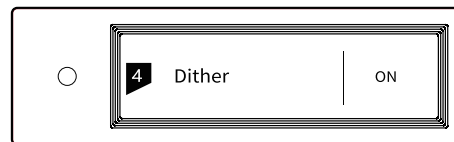

### 5.5 Jitter Eliminator

Set the internal time-base jitter elimination circuit for turn ON or OFF.

- ON (Default)
- OFF

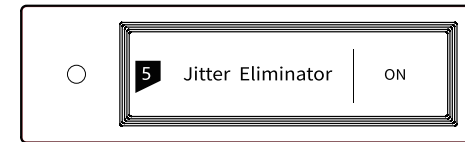

### 5.6 DPLL Bandwidth

Set the DPLL Bandwidth

- Low: Low bandwidth
- High: High bandwidth
- Normal: Standard bandwidth (Default)

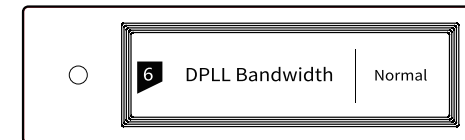

It's recommended to set the DPLL bandwidth to default, when the quality of digital signal which output from front-end device is poor and the element M can not lock the signal stably, please select high bandwidth, while the sound quality may be reduced under high bandwidth mode.



5.7 IIS-LVDS Port Definition

There are two kinds of IIS-LVDS port definition for option, two different definitions as shown bellow,

TYPE A (Default)

TYPE B

TYPE C

TYPE D

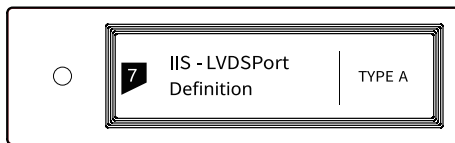

Please select 'TYPE A' when collocated with Matrix audio products.

5.8 Dimmer

In order to avoid the interference from the LED indicator and the screen, element M can enter dimmer mode after no operation for 5 minutes, when turn on this option. At dimmer mode, the LED indicator will reduce brightness and the screen will turn off. The screen can be activated by operating on the remote control or on the unit body. Turn off this option to prevent element M enter dimmer mode.

ON (Default)

OFF

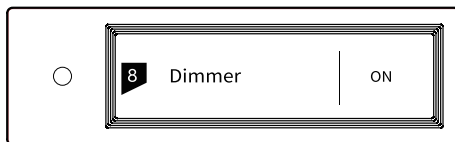

5.9 Auto Sleep

When there is no input signal from the selected channel and no operation for more than 5 minutes, element M will enter Sleep mode. element M will not enter 'Auto Sleep' mode when 'Auto Sleep' function is off.

ON

OFF (Default)

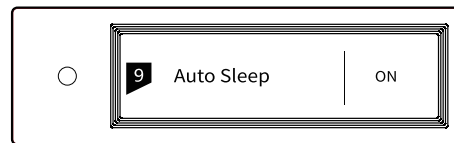

5.10 User defined button settings

Set the function of 'O' button on the front panel There are three functions available:

INPUT: Set as input channels switching shortcut

OUTPUT: Set as output channels switching shortcut (Default)

FILTER: Set as filters switching shortcut

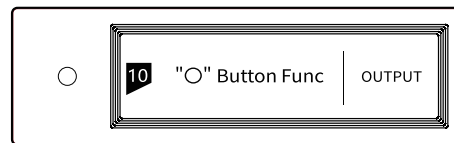

5.11 Network Type

Select network access method for element M, when you select the option LAN, Wi-Fi is disabled and vice versa if you select Wi-Fi, ethernet is disabled.

LAN: Wired network

Wi-Fi: Wireless network (Default)

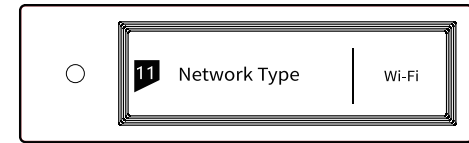

5.12 Remote Control

If there are more than 1 Matrix device in the same place, in order to prevent one remote control from controlling multiple device at the same time, element M has built-in 5 sets of remote control address codes, which can be switched under this option to achieve 'one-to-one' control between the remote control and the host.

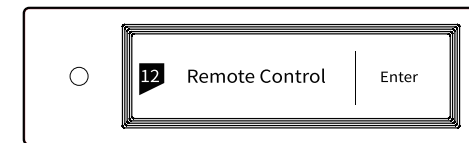

Press the knob to enter the remote control settings as shown below, at this time, you will see the current remote control address code on the screen, press the button on the remote control and the screen will display the corresponding name. Hold the Standby and Filter buttons on the remote control for 5 seconds at the same time, the screen will display a new address code, press the 2 buttons again within 5 seconds to switch to the next address code, repeat the operations above to select the address code, press '≡' or '○' to return to the menu page.

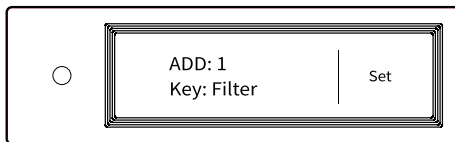

### 5.13 Load Default

Press the knob in this option, all the settings will return to default.

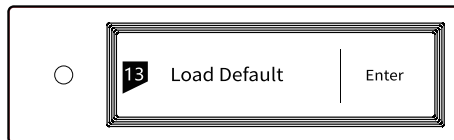

### 5.14 Product Information

Push the knob under this option, the hardware and software information will shown on the screen.



## 6. Appendix

### 6.1 Audio file formats and sampling rate supported

MA player supports the following audio file formats: Mp3, WMA, WAV, AIF, AIFC, AIFF, AAC, FLAC, OGG, APE, ALAC, M4A, DSF, DFF

PCM sampling rate support up to:

PCM 16/24/32Bit 44.1kHz, 48kHz, 88.2kHz, 96kHz, 176.4kHz, 192kHz, 352.8kHz, 384kHz, 705.6kHz, 768kHz

DSD sampling rate support up to:

DSD 2.8 MHz, 5.6 MHz, 11.2 MHz, 22.4MHz

More audio file formats could be supported through future firmware updates.

### 6.2 About MQA (Master Quality Authenticated)

MQA is an award-winning British technology that delivers the sound of the original master recording. The master MQA file is fully authenticated and is small enough to stream or download.

'MQA' or 'MQA.' indicates that the product is decoding and playing an MQA stream or file, and denotes provenance to ensure that the sound is identical to that of the source material.

'MQA.' indicates it is playing an MQA Studio file, which has either been approved in the studio by the artist/producer or has been verified by the copyright owner. The MA player delivers the final unfold of the MQA file and displays the original sample rate of the file. The sampling rate for MQA encoded playback covers 44.1k-384kHz.

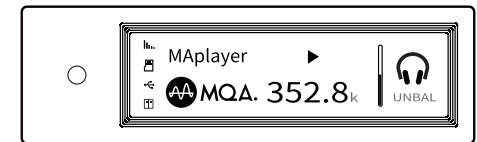

### 6.3 USB storage device requirements

- element M can use devices that comply with the USB mass storage standard, but cannot guarantee compatibility with all storage devices or memory cards.
- USB storage devices support FAT32, exFAT, NTFS formats.
- If the USB storage device is partitioned, each partition will be treated as a separated device.
- When using extension cable to connect a USB storage device may result in unstable connection.
- When using a USB hub to connect the USB storage device to element M, it may not work properly.
- The USB port of element M cannot supply more than 500 mA to the peripherals.
- If USB storage device comes with a power adapter, please connect power adapter to the storage device.

**CAUTION**

Matrix Audio is not responsible for data loss, modification, or failure to the USB storage devices. We strongly recommend you back up the data in the USB storage device before using it on element M.

### 6.4 IIS-LVDS Port

The IIS port of element M is a standard 19-pin HDMI connector. It uses four sets of LVDS differential signals to transmit IIS data. It supports up to 32Bit/768kHz PCM signal input and 1Bit/45.1MHz DSD signal input. The PCM format is the standard IIS format, the DSD format supports the original DSD format (Native DSD) and the DSD format of DoP encoding.

The IIS port of element M is compatible with TYPE A, B, C and D. These are 4 different interface definitions, which can be configured in the 8th setting option.

The port definition as shown bellow:

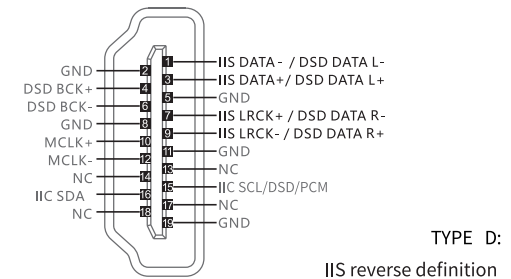
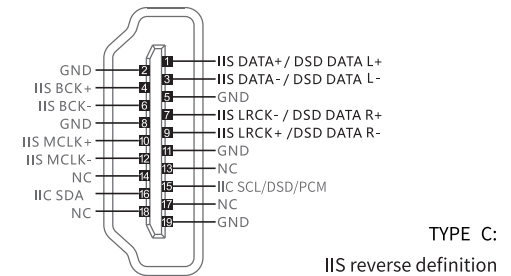
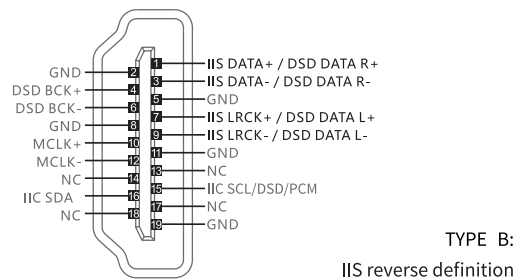
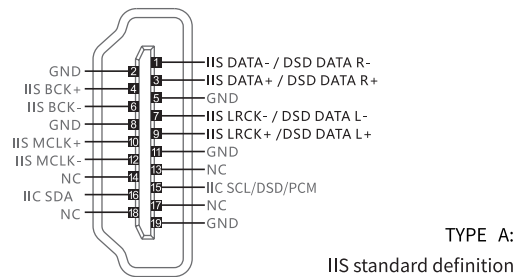

### 6.5 Technical Specifications

#### Digital Input

##### COAXIAL & OPTICAL:

PCM 16-24Bit/44.1kHz, 48kHz, 88.2kHz, 96kHz, 176.4kHz, 192kHz

##### DSD DSD64(DoP)

##### IIS-LVDS:

PCM 16-32Bit /44.1kHz, 48kHz, 88.2kHz, 96kHz, 176.4kHz, 192kHz, 352.8kHz, 384kHz, 705.6kHz, 768kHz

DSD DSD64/128/256/(DoP)DSD  
DSD64/128/256/512/1024(Native)

USB Audio: PCM 16-24Bit /44.1kHz, 48kHz, 88.2kHz  
 96kHz, 176.4kHz, 192kHz, 352.8kHz  
 384kHz, 705.6kHz, 768kHz  
 DSD DSD64/128/256(DoP)  
 DSD DSD64/128/256/512(Native)

**Line Output**

**XLR**

XLR Pin Definition:

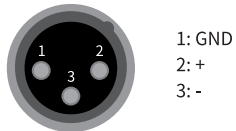

SNR: > -128dB  
 THD+N: <0.00022%@1kHz  
 <0.00025%@20Hz-20kHz  
 Frequency Response: 20Hz-20kHz ±0.05  
 -3dB@150kHz  
 Crosstalk: > -145dB  
 Amplitude: 4.0VRMS@0dB

**RCA**

SNR: > -125dB  
 THD+N: <0.00028%@1kHz  
 <0.00045%@20Hz-20kHz  
 Frequency Response: 20Hz-20kHz ±0.05  
 -3dB@120kHz  
 Crosstalk: > -128dB  
 Amplitude: 2.0VRMS@0dB

**Headphone Output**

TRS 6.35mm Definition:

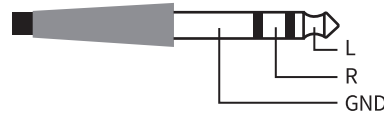

**XLR3 Definition**

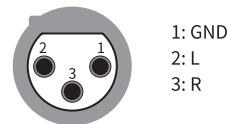

SNR: > -111dB@2VRMS  
 THD+N: <0.0006%@1VRMS  
 Frequency Response: 20Hz-20kHz±0.1 -3dB@47kHz  
 Output Impedance: <0.6Ω  
 Output Power: 1320mW@33Ω, 248mW@300Ω, 124mW@600Ω  
 (1%THD)  
 Gain: +12dB

**Network**

LAN: 10BASE-T/100BASE-TX  
 WLAN: 2.4GHz/5GHz, IEEE 802.11 a/b/g/n/ac standard

**Power Supply**

Power Voltage:

230V position is fit for AC220V-240V 50/60Hz  
 115V position is fit for AC100V-120V 50/60Hz  
 Standby Power Consumption: < 1W  
 Sleep Power Consumption: < 4W  
 Max Power Consumption: < 25W

**Dimension**

340x2801x60mm (LxWxH, including the protruding part)

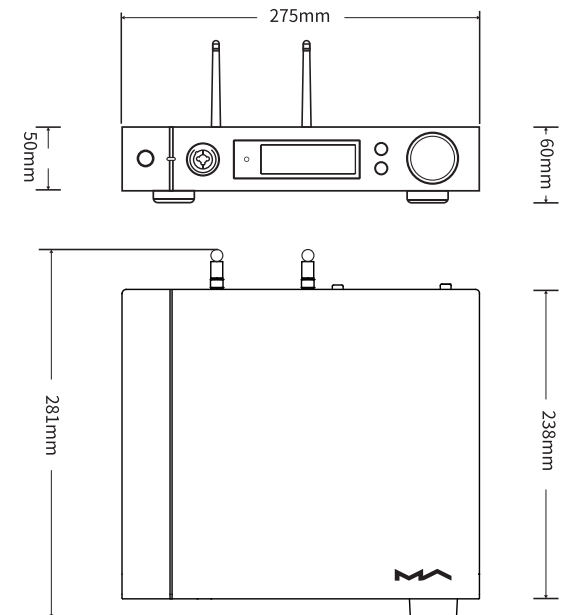



### Weight

3.7kg

For improvement purpose, specifications subject to changes without prior notice.

The product with Hi-Res Audio logo is conformed to High-Resolution Audio standard defined by Japan Audio Society. This logo is used under license from Japan Audio Society.

MQA and the Sound Wave Device are registered trade marks of MQA Limited.© 2016