

48" 3-POINT HITCH SLASHER TOPPER

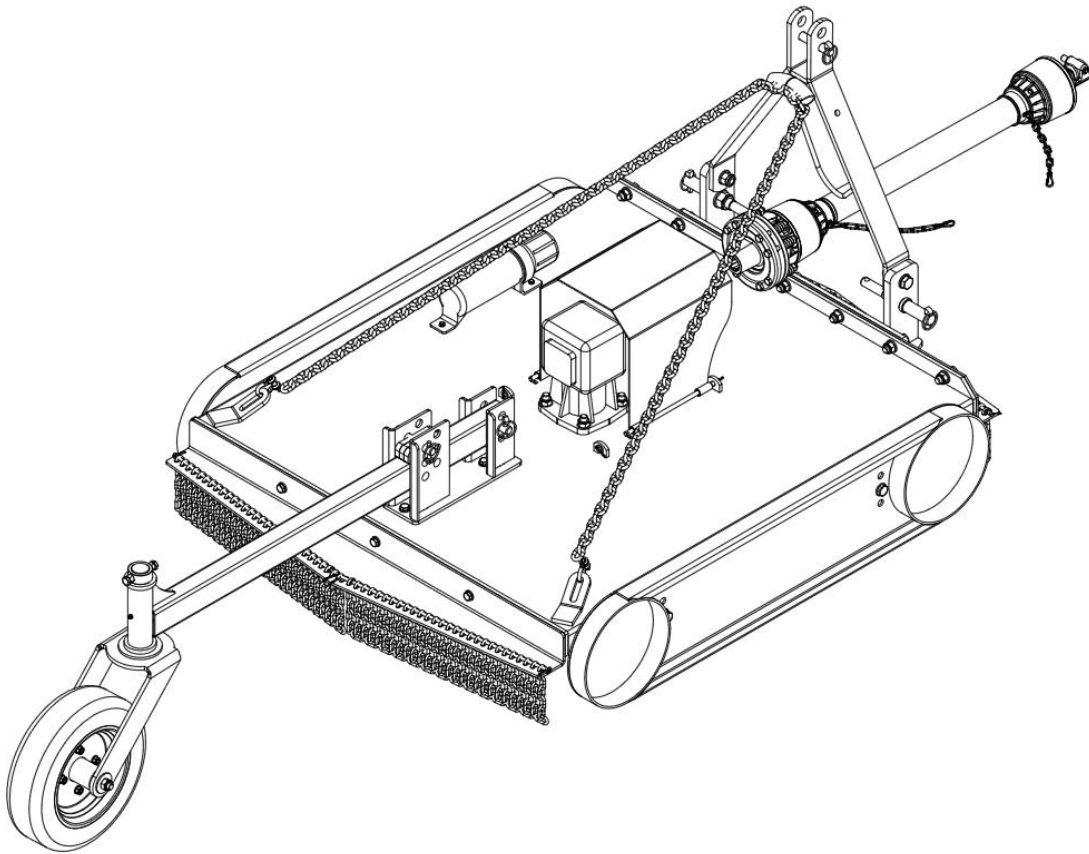

▲ WARNING



- Please read and understand the product manual completely before assembly
- Check against the parts list to make sure all parts are received
- Wear proper safety goggles or other protective gears while in assembly
- Do not return the product to dealer. They are not equipped to handle your requests.

Missing parts or questions on assembly?

Please call: 1-877-761-2819 or email: cs@tmgindustrial.com

TABLE OF CONTENTS

SAFETY INSTRUCTIONS.....	3
GENERAL SAFETY GUIDELINES.....	4
PRODUCTS SPECIFICATIONS.....	7
PARTS DESCRIPTION AND FUNCTION.....	8
SAFETY DECAL LOCATIONS.....	9
UNPACKING & ASSEMBLY.....	11
CONNECTING TRACTOR.....	18
PRIOR TO OPERATION.....	20
MAINTENANCE.....	23
STORAGE	27
TROUBLESHOOTING.....	27
EXPLODED VIEW & PARTS LIST.....	29

IMPORTANT SAFETY INFORMATION

Safety Instructions

Good safety practices not only protect you but also the people around you. Please ensure that everyone using his equipment is familiar with the recommended operating and maintenance procedures, has read and understood the Operators Manual and follows all the safety precautions. Most accidents can be prevented. Do not risk serious injury or death by ignoring good safety practices.

The alert symbol is used throughout this manual and this manual and on the product safety decals. This symbol indicates attention is required and identifies hazards concerning your personal safety and the safety of others. Please follow the recommended precautions



The safety alert symbol means...
ATTENTION! BECOME ALERT! YOUR SAFETY IS INVOLVED!



CAUTION

The Caution Symbol indicates a potentially hazardous situation that, if not avoided, may result in minor or moderate injury. It may also be used to alert against unsafe practices.



WARNING

The Warning Symbol indicates a potentially hazardous situation that, if not avoided, could result in death or serious injury and includes hazards that are exposed when guards are removed. It may also be used to alert against unsafe practices.



DANGER

The Danger Symbol indicates an imminently hazardous situation that, if not avoided will result in death or serious injury. This signal word is to be limited to the most extreme situations, typically for machine components that, for functional purposes, cannot be guarded.

General Safety Guidelines

- Have a first-aid kit available for use and know how to use it.
- Have a fire extinguisher available, stored in a highly visible location and know how to use it.
- Wear appropriate protective gear. This list may include but is not limited to:
 - hard hat
 - protective shoes with slip resistant soles and steel caps
 - protective glasses or goggles
 - heavy gloves
 - wet weather gear
 - hearing protection
 - respirator or filter mask
- Read and understand the Operator's Manual and all safety decals before operating, servicing, adjusting, repairing or hitching the equipment.
- Do not attempt any unauthorised modifications to your product as this could affect function or safety and could affect the life of the equipment.
- Never start or operate the Slasher except from the operators station on the power unit.
- Inspect and clean the working area before operating. Remove all obstructions such as rocks, stumps and wire.
- Keep hands, feet, clothing, and hair away from moving parts.
- Ensure bystanders are clear of the area before operating. A minimum distance of 100 meters should be kept from all bystanders when Slasher is in operation.
- Never operate this equipment while using alcoholic beverages or drugs that can hinder alertness or coordination. Consult your doctor about operating this machine while taking any medication.
- Under no circumstances should children under the age of 18 be allowed to work with or around this equipment. Do not allow anyone to operate or assemble this equipment until they have read and understood this manual.
- This equipment is dangerous to anyone unfamiliar with its operation. The operator should be responsible, properly qualified and physically able person familiar with farm machinery and competent in this equipment operation.
- All new operators or owners must review the manual before using the equipment and at least annually thereafter.
- In order to provide a clear view, certain illustrations in this manual may show an assembly with a safety guard removed equipment should never be operated in this condition. Keep all guards in place. If guard removal becomes necessary for repairs, reinstall the guards prior to use.
- Replace any safety decal that is not legible or is missing. The locations of such safety decals are indicated in this manual.
- Never exceed the limits of a piece of machinery. If its ability to do a job, or to do so safely, is in question -DONT TRYIT.
- In addition to the design of this implement, safety decals and safety equipment, accident prevention is dependent upon the awareness, common sense, forethought, and proper training of everyone involved in the operation, transport, maintenance and storage of the machine. Also refer to safety messages and operating instructions in each of the appropriate sections of the tractor manual. Pay close attention to the safety decals affixed to the tractor and the Slasher.

Employer/Controller Responsibilities

OH&S legislation places obligations on the employer, or the controller of the Slasher, to identify the hazards and control the risks associated with the use of the Slasher in their workplace and to do so in accordance with the manufacturer's instructions.

When purchasing a Slasher:

- Ensure the manufacturer's instructions are provided at the point of purchase.
- Ensure the Slasher conforms to industry safety standards.
- Discuss your needs with the supplier, to ensure the Slasher is compatible with the power of your tractor and is appropriate for the intended application-consider the speed of your tractor's PTO and its compatibility with the Slasher's gearbox.
- Seek practical advice and instruction from the supplier on the use and limitations of the Slasher. If you are hiring, leasing or borrowing a Slasher on a temporary basis, get safe use instructions from the person supplying it.
- The employer must provide safety instructions to all those involved in using a Slasher.
- A copy of safety instructions must be kept in good condition with the Slasher.
- Generally, the safety instructions should be the manufacturer's instructions. Any variations from the manufacturer's instructions must be based on a risk assessment and must not remove any of the safety features nor expose anyone to risks.

Supervision, Instruction and Training

The employer must provide safe systems of work, adequate supervision, instruction and training to all those involved in using a Slasher. They must be instructed in the safe operation of the Slasher, including hazards specific to the workplace, including the terrain, stability of the tractor, working environment and the like. The employer should ensure that everyone achieves a level of understanding that enables them to safely and competently operate the Slasher.

Inspection, Maintenance and Repair

- The Slasher must be inspected according to the manufacturer's instructions, prior to use. See page 25 for Maintenance Instructions.
- All problems identified must be rectified, prior to use.
- The Slasher must be maintained according to the manufacturer's instructions.
- Replacement parts must be to the original manufacturer's specifications or their equivalent.
- Safety signs and decals should be legible, maintained and where necessary replaced. · Repairs should be carried out by a competent person.
- When suspending the Slasher for maintenance or repair, whether attached to the tractor or suspended in another way, adequate safety stands must be used to prevent inadvertent lowering of the Slasher.

Service and Maintenance Safety

- Stop engine, set brake, remove ignition key and wait for all moving parts to stop before servicing, adjusting, repairing or unplugging.
- Support the equipment with blocks or safety stands before working beneath it.
- Follow good shop practices including:
 - keep service area clean and dry
 - be sure electrical outlets and tools are properly grounded
 - use adequate light for the job.
- Use only tools, jacks and hoists of sufficient capacity for the job.
- Replace and secure all shields removed during servicing before operating.
- Use heavy leather gloves to handle sharp objects.

Start-up Safety

- Do not let inexperienced operators or children use this equipment.
- Place all tractor and machine controls in neutral before starting.
- Operate only with Roll Over Protective System(ROPS) and seat belt equipped tractors.
- Do not operate inside a building unless there is adequate ventilation.
- Ensure all shields are in place and in good condition before operating.
- Stay clear of PTO shaft and machine when engaging PTO.

Operation

Prior to use, the Slasher should be inspected to ensure it is working correctly. All safety features must be included in this inspection. If any safety feature is not working correctly, the Slasher must not be used. The Slasher must be operated according to the manufacturer's instructions.

The operator must ensure that no-one is exposed to risks arising from the slashing operation.

Additional safety controls may be required when operating in the vicinity of people or traffic - e.g. alongside highways, roads or other public areas.

Where adjustable or removable guarding is provided for specific applications, such as vineyards and horticulture, and the guarding has been removed or is no longer effective, appropriate control measures must be implemented. These controls must ensure that the risk of injury is eliminated or controlled. Before using a Slasher in an application other than that outlined above, the guards must be readjusted or replaced so as to be effective.

Operation Safety

- Do not permit riders.
- Do not wear loose fitting clothing during operation.
- Never operate over 540 PTO rpm speed.
- Never operate the equipment in the raised position.

Personal Protective Equipment(PPE)

Prior to use, a risk assessment must be undertaken to determine the appropriate PPE required. Any identified PPE must be provided by the employer and must be used by those involved in the operation and maintenance of the Slasher. Examples of PPE are appropriate footwear and hearing & eye protection.

Storage and Transport

When not in use, the Slasher must be transported and stored according to the manufacturer's instructions. Requirements may differ when transporting a Slasher within a property and on a public road - you must comply with all statutory requirements.

Storage Safety

- Store the unit in an area away from human activity.
- Do not permit children to play on or around the stored machine.
- Support the frame on stands and blocks to provide a secure base.

Transport Safety

- Review Transport Safety instructions in tractor manual before moving.
- Check with local authorities regarding transport on public roads. Obey all applicable laws and regulations.
- Make sure the SMV (Slow Moving Vehicle) emblem and all the lights and reflectors that are required by the local highway and transport authorities are in place, are clean, and can be seen clearly by all overtaking and oncoming traffic.
- Never have the equipment in operation during transport.
- Always travel at a safe speed.

Modifications

A Slasher should not be modified or altered. However, if it is necessary to make modifications, they must be done by a competent person and based on a risk assessment. All modifications must comply with this industry safety standard.

Before any modifications are done, contact the manufacturer or supplier.

Anyone who undertakes modifications subsequently assumes the role and responsibilities of the designer and manufacturer.

This does not include shortening a PTO shaft and cover when first installing the Slasher on a tractor (refer to page 19 for details).

The instructions relating to the Slasher and its use may need to be revised following a modification. Any modifications made without manufacturers approval will void Warranty.

Safety Signs

- Refer pages 9-10 for the approximate location and detail of safety signs.
- Keep all safety signs clean and legible and replace any that are damaged or missing.
- When original parts are replaced, any safety signs affixed to those parts should be replaced as well. Replacement safety signs are available from your local dealer.

Installation of Safety Signs

- To install safety signs, ensure the installation area is clean and dry. Decide on the exact position before you remove the backing paper. Remove the smallest portion of the split backing paper and align over the specified area. Carefully press in place.
- Slowly peel back the remaining paper and smooth the remaining portion in place. Small air pockets can be pierced with a pin and smoothed out.

PRODUCTS SPECIFICATIONS

Model	TMG-TST48
Working width	48"
Cutting height	1-1/2"-4"
Blade No	2
Tractor horsepower	35~45 HP
PTO speed	540 RPM
Power From	PTO shaft
Hitch type	CAT 1 & CAT2
Weight	750lb
Packing Size	65"x51"x22"

PARTS DESCRIPTION AND FUNCTION

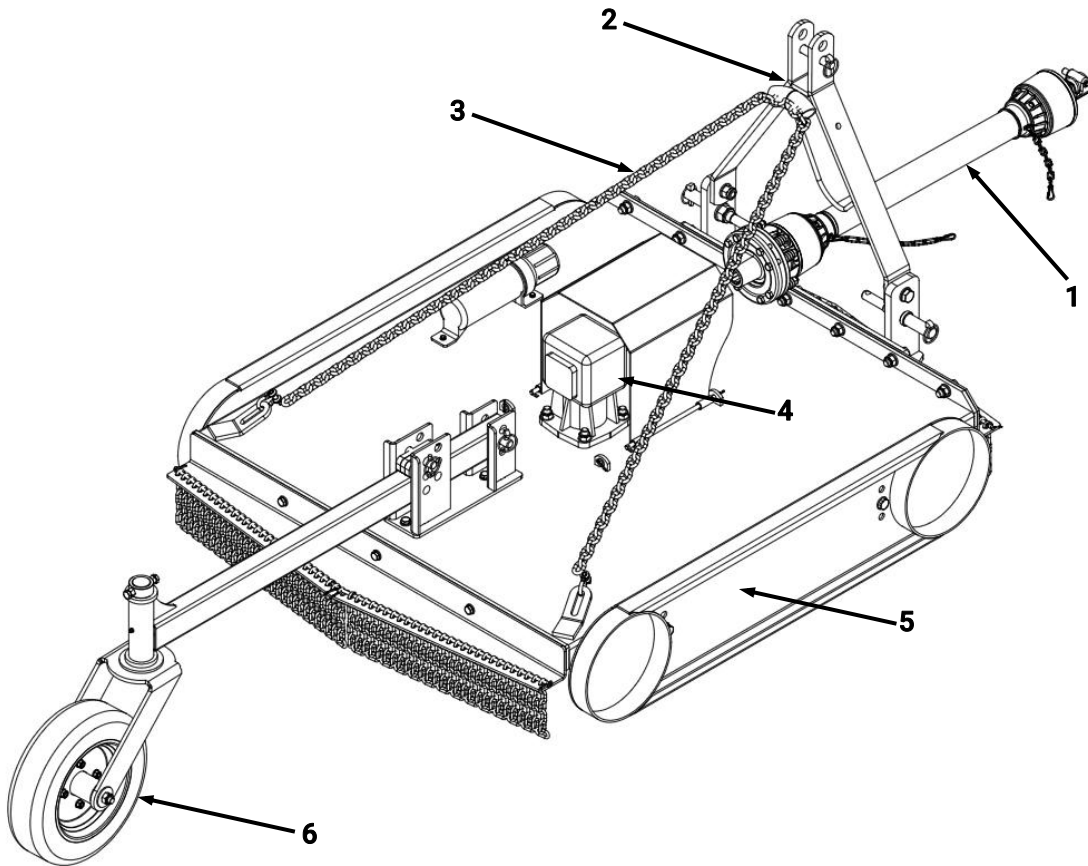

1. **PTO shaft** Transfer the tractor power output to the gearbox
2. **Three-point linkage** Connect tractor and Slasher
3. **Lifting chain** Coordinate three point suspension to adjust cutting height
4. **Gearbox** Change the output speed of the tractor and transmit power to the blade axle.
5. **Skateboard welds** Support when mowing normally, blocking already cut grass and twigs to prevent spatter injury, adjust cutting height
6. **Tail wheel** Support when mowing normally, adjust cutting height

SAFETY DECAL LOCATIONS

The safety decals and their positions are shown on the illustration below. Good safety requires that you familiarize yourself with the various safety decals, the type of warning and the area or specific function related to that area that requires your SAFETY AWARENESS.

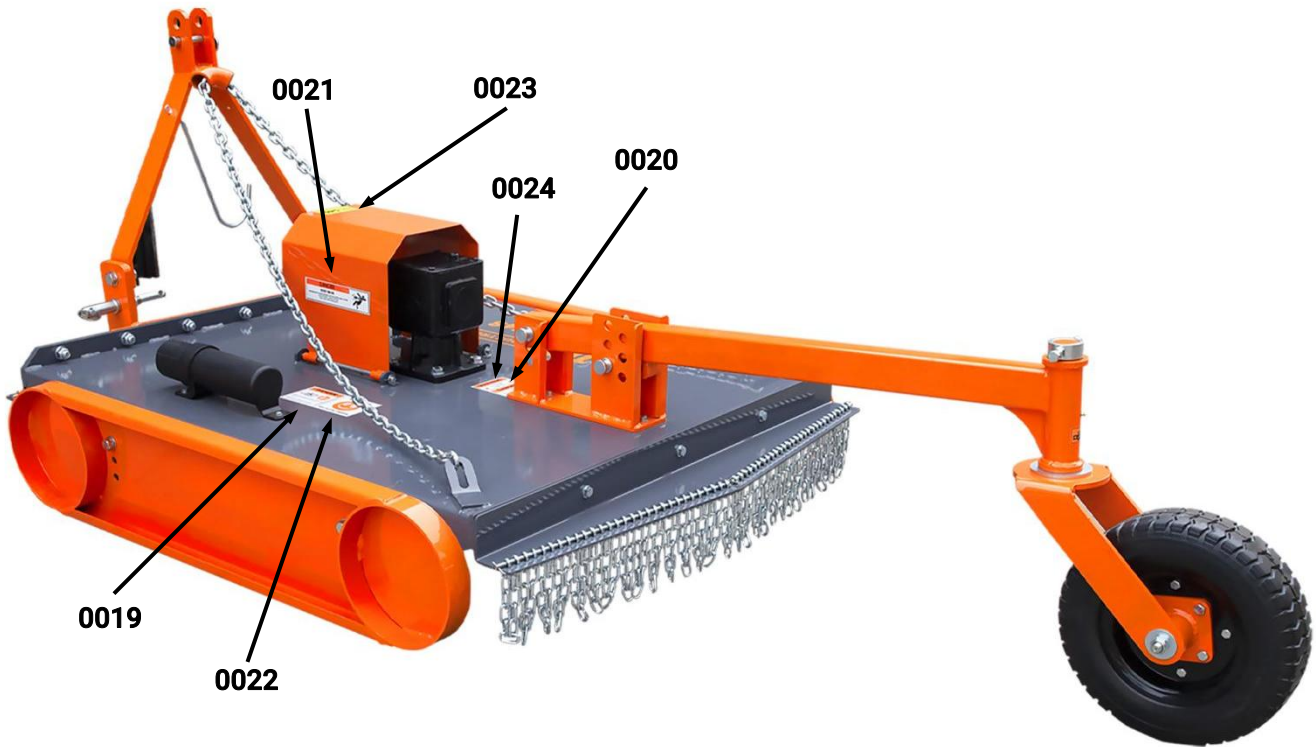



DANGER



DO NOT start, operate or service machine until you read and understand the operator's manual.

Failure to do so could result in **DEATH** or **SERIOUS INJURY**, or damage to equipment.

TMG-GNRL-0019

HEARING PROTECTION



MUST BE WORN

TMG-GNRL-0022

DANGER

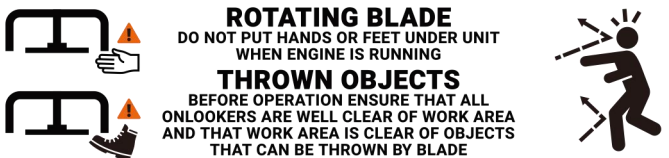

ROTATING BLADE
DO NOT PUT HANDS OR FEET UNDER UNIT WHEN ENGINE IS RUNNING

THROWN OBJECTS
BEFORE OPERATION ENSURE THAT ALL ONLOOKERS ARE WELL CLEAR OF WORK AREA AND THAT WORK AREA IS CLEAR OF OBJECTS THAT CAN BE THROWN BY BLADE

TMG-GNRL-0020

WARNING



STRICTLY NO RIDING ON MACHINE.

DO NOT CARRY PASSENGERS AT ANY TIME.

TMG-GNRL-0024

MAX PTO 540 RPM

TMG-GNRL-0023

DANGER

KEEP BACK

Entanglement in rotating driveline can cause serious injury or death.
Keep all shields in place at all times.
Avoid contact with rotating parts.



UNPACKING & ASSEMBLY

1. After unpacking, check the following components

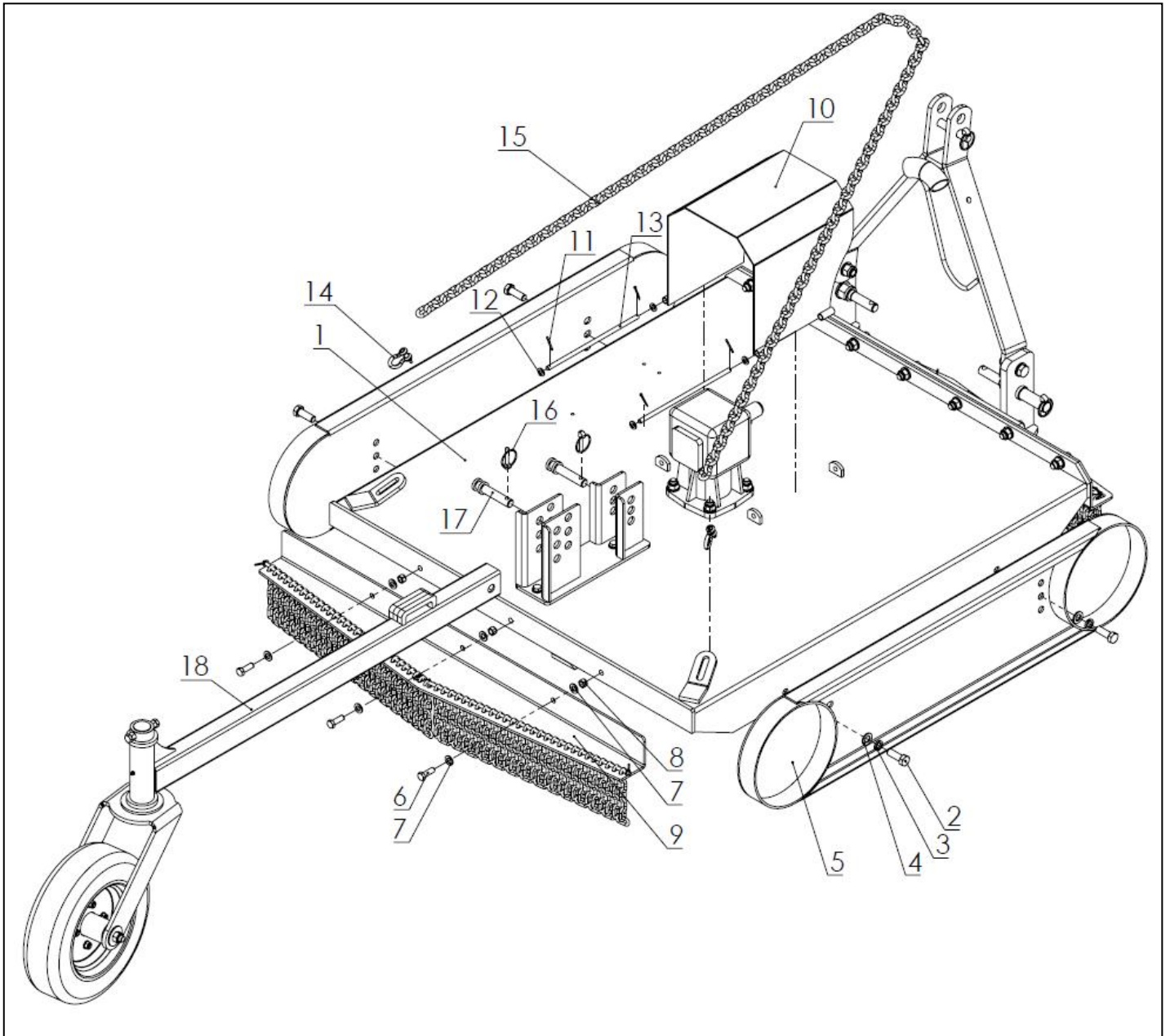

The parts marked with numbers in the figure are the parts that need to be assembled.

*. All numbers are not part numbers in the drawings. For correct part numbers, see explosive diagram.

NO.	DESCRIPTION	QTY	NO.	DESCRIPTION	QTY
1	Host	1	10	Gearbox cover welds	1
2	Full thread hexagon bolt M16x45	4	11	Cotter pin 3.2x25	4
3	Spring washer Ø16	4	12	Flat washer Ø10	4
4	Flat washer Ø16	4	13	Housing connecting pin	2
5	Skateboard Welds	2	14	Lock accessories	2
6	Full thread hexagon bolt M12x35	3	15	Lifting chain 8x8x24-107	1
7	Flat washer Ø12	6	16	Lock pin	2
8	Hex lock nut M12	3	17	Tail wheel connecting pin	2
9	Rear chain plate assembly	1	18	Tail wheel assembly	1

*.All numbers are not part numbers in the drawings. For correct part numbers, see explosive diagram.

TOOLS FOR INSTALLATION				
NO	DESCRIPTION	SPECIFICATION	CONDITIONS OF USE	QTY
1	Open End Wrench	18/24	M12,M16 bolt tightening	2
2	Air Impact Wrench	1280t	Tighten the bolt with the corresponding socket instead of the Wrench	1
3	Hammer			1
4	Torque Wrench	10-220N·m	Measuring torque	1

After the parts are confirmed to be correct and the tools for installation are ready, start the assembly. The specific operation steps are described below.

2. Install skateboard assembly

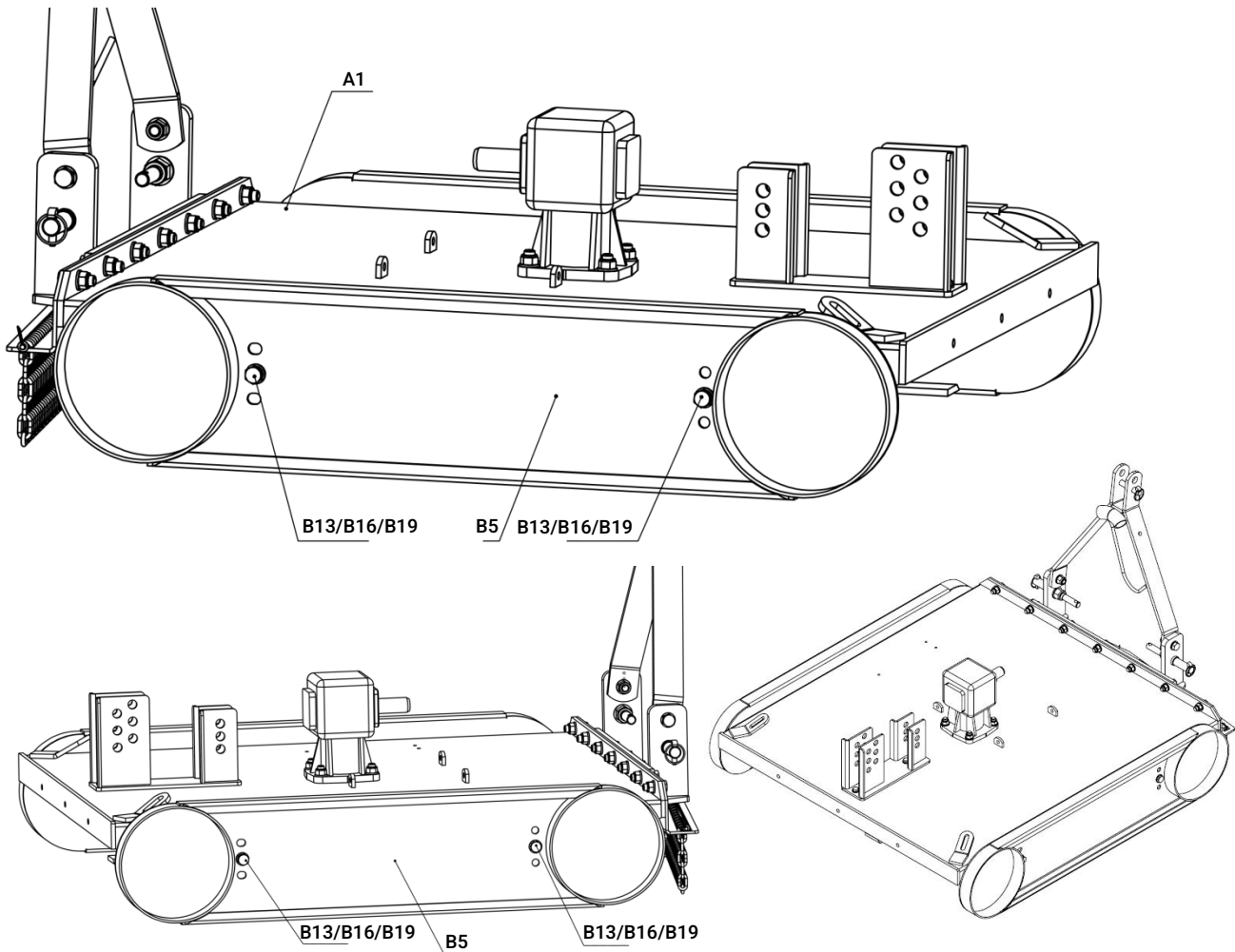

Installation steps:

Lift the HOST(A1) with a forklift, place the SKATEBOARD WELDS (B5) on the two side of the host as shown in the figure above, align with the mounting holes on the host, and install the FLAT WASHER(B13), SPRING WASHER(B19), and BOLT(B16) in sequence, tighten with a wrench.

Importance: All bolts are locked in place without shaking.

NOTE: M16 Torque is 193-257 N·m



WARNING: Once the assembly bolts are not fastened in place, there will be abnormal noises when the machine is working.

PART NO.	DESCRIPTION	QTY
A1	Connecting shaft 35x270	1
B5	Skateboard Welds	1
B13	Flat washer Ø16	4
B16	Full thread hexagon bolt M16x45	4
B19	Spring washer Ø16	4

3. Install rear chain plate assembly

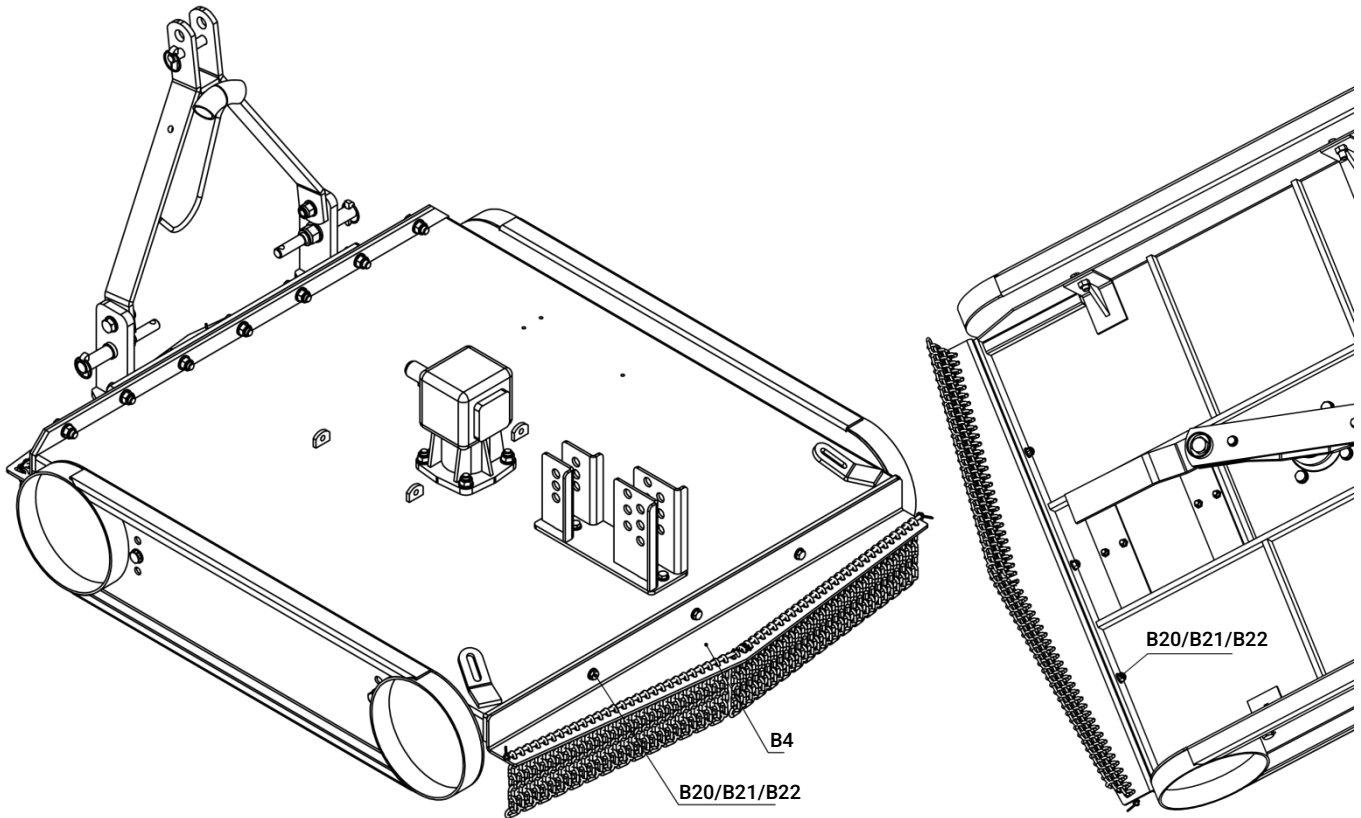

Installation steps:

Place the REAR CHAIN PLATE ASSEMBLY (B4) in the position shown in the figure above, align it with the mounting holes on the host, and fasten it with BOLTS(B22), FLAT WASHER(B20) and LOCKNUTS(B21). (Note: One flat washer is placed on the bolt surface and the nut surface)

Importance: All bolts are locked in place without shaking.

NOTE: M12 Torque is 78-104 N·m



WARNING: Once the assembly bolts are not fastened in place, there will be abnormal noises when the machine is working.

PART NO.	DESCRIPTION	QTY
B4	Rear chain plate assembly	1
B20	Full thread hexagon bolt M12x35	3
B21	Flat washer Ø12	6
B22	Hex lock nut M12	3

4. Install gearbox cover

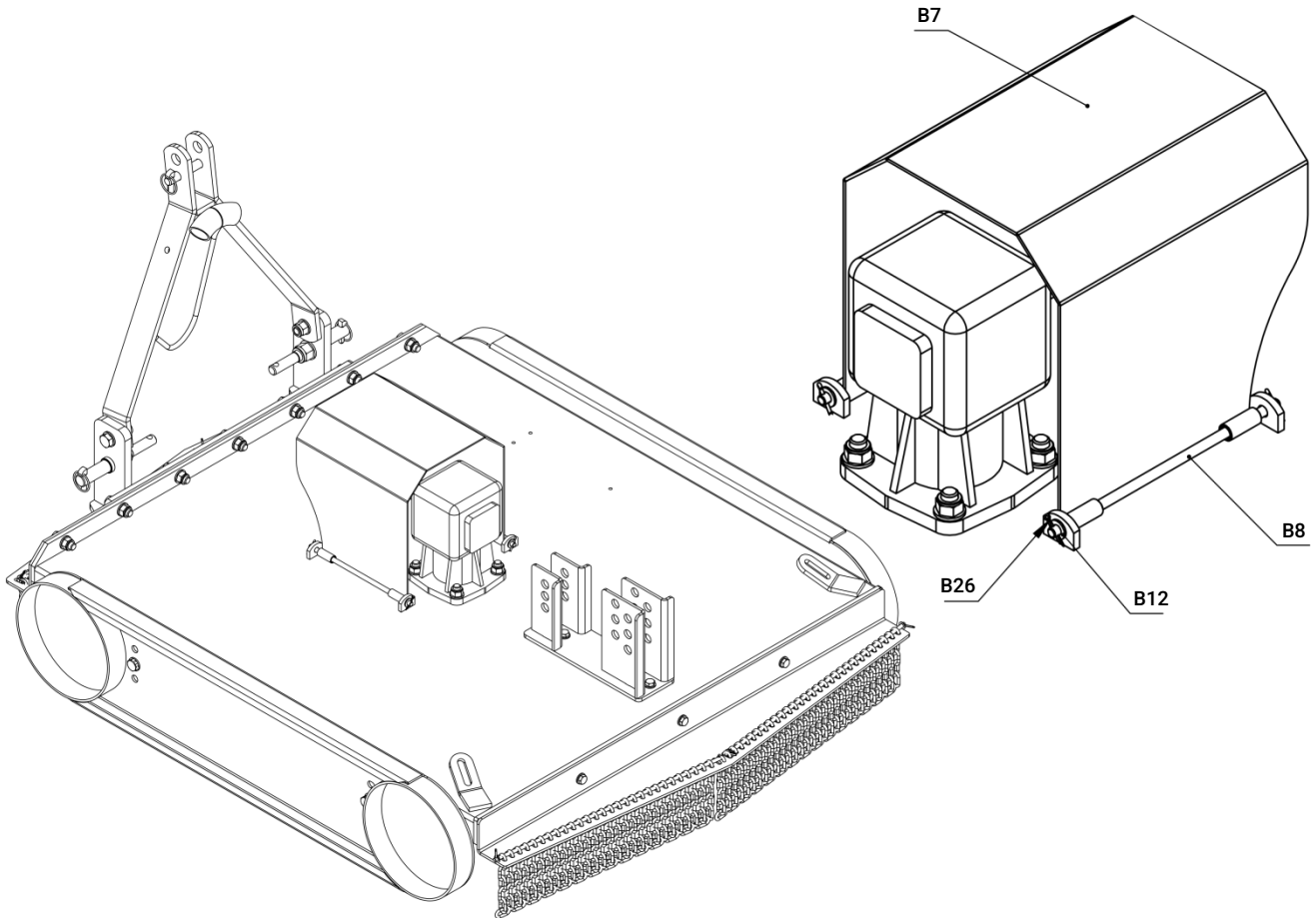

Installation steps:

Place the GEARBOX COVER WELD (B7) in the position shown above, and use the HOUSING CONNECTING PIN (B8) to pass through the connecting plate on the host, on both sides of the HOUSING CONNECTING PIN (B8) insert one FLAT WASHER(B12) each and insert COTTER PIN(B26) to secure it.

Importance: All bolts are locked in place without shaking.



WARNING: Once the assembly bolts are not fastened in place, there will be abnormal noises when the machine is working.

PART NO.	DESCRIPTION	QTY
B7	Gearbox cover welds	1
B8	Housing connecting pin	2
B12	Flat washer Ø10	4
B26	Cotter pin 3.2x25	4

5. Install the lifting chain

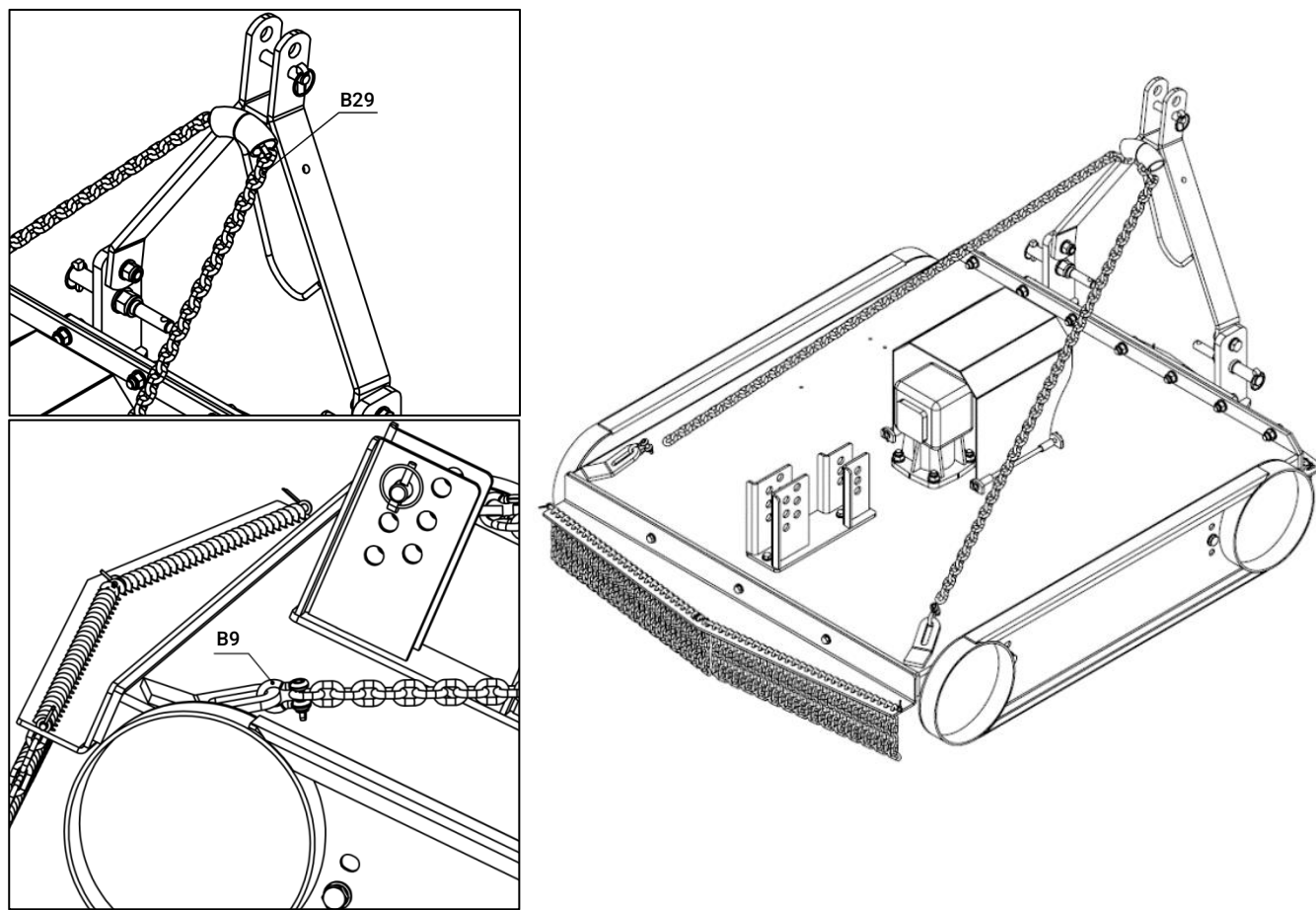

Installation steps:

As shown above, pass the LIFTING CHAIN (B29) through the connecting sleeve on the THREE-POINT LINKAGE, place the LOCK (B9) on the chain connection plate of the host, and secure the chain with the lock.

Importance: All bolts are locked in place without shaking.



WARNING: Once the assembly bolts are not fastened in place, there will be abnormal noises when the machine is working.

PART NO.	DESCRIPTION	QTY
B9	Lock accessories	2
B29	Lifting chain 8x8x24-107	1

6. Install the tail wheel assembly

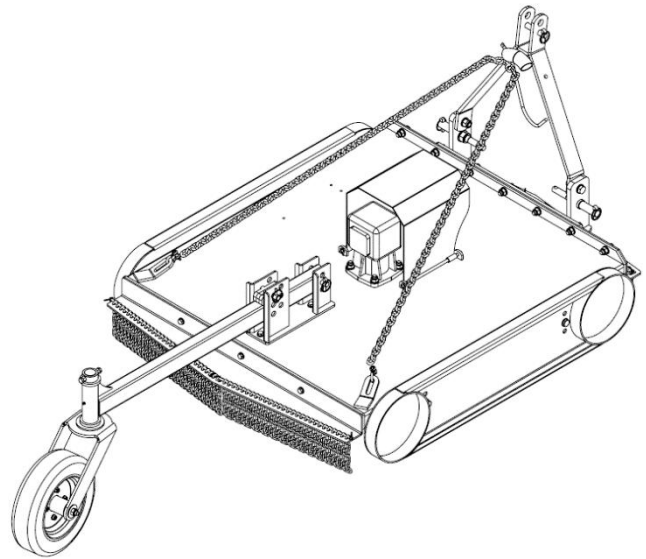
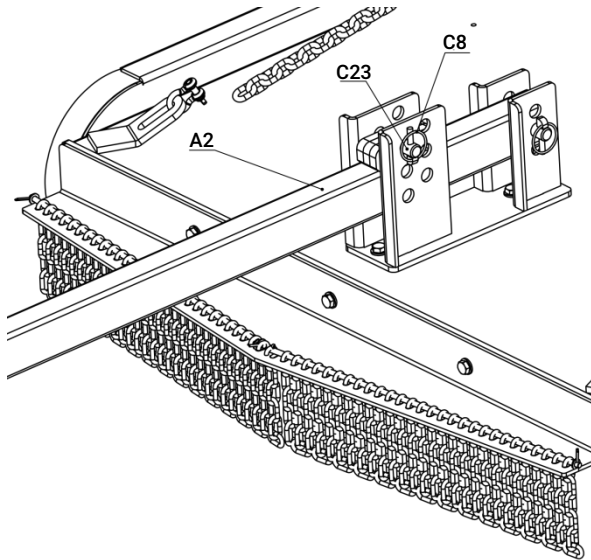

Installation steps:

Position the TAIL WHEEL ASSEMBLY (A2) as shown, align with the mounting holes on the host, pass the TAIL WHEEL CONNECTING PIN (C23), and insert the LOCK PIN (C8) to secure it.

Importance: All bolts are locked in place without shaking.



WARNING: Once the assembly bolts are not fastened in place, there will be abnormal noises when the machine is working.

PART NO.	DESCRIPTION	QTY
A2	Tail wheel assembly	1
C8	Lock pin	2
C23	Tail wheel connecting pin	2

CONNECTING TRACTOR

1. Three-point linkage



WARNING !

In the process of connection, when the tractor is moving, if there is people between the tractor and working machine, it may cause injury accident. Be sure no people stand between the tractor and working machine during the tractor moving.

LOWER LIFTING PIN TYPES	
TMG-TST48	CAT1 &CAT2

2. Connection and adjustment



CAUTION !

Make sure the tractor is fixed in the process of connection

- Start the tractor engine, tractor and machine head lower link under suspension corresponds to the position of the pin, rewind, stop, stop the engine, put up parking stalls.
- Connect Left towing arm, the left arm on the tractor towing the working machine is left hanging inserted pin, the locking detent. Right arm pulling the same way.
- Adjust the towing arms in the same height, as shown right:

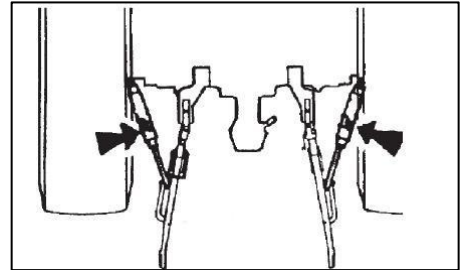

If the magnitude of the tractor towing arms is too narrow, adjust the left suspension pin inward as right:

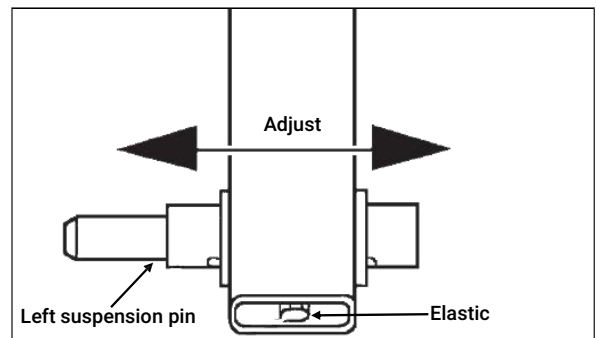

- Adjust angle, to obtain the most appropriate cutting angle, adjust the upon 3-point linkage suspension to ensure the suitable cutting angle.

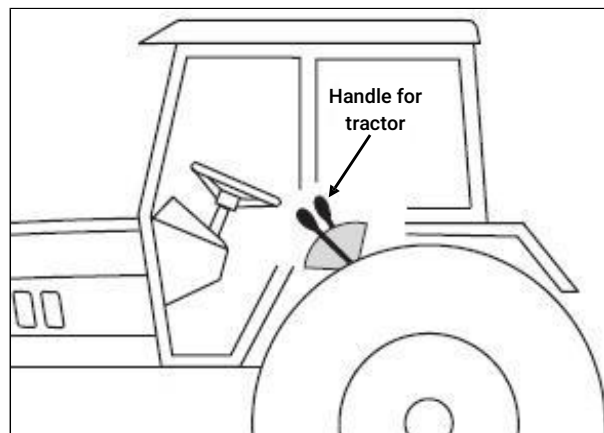
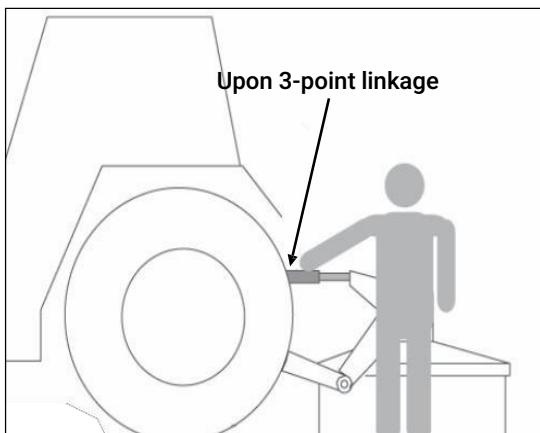

3.PTO Installation

In some cases it will be necessary to shorten the PTO assembly to match your particular tractor. The following procedure should be used:

1. Check that the driveline is the correct length. The minimum coupling length (overlap) must be no less than 150mm (6 inches) in each work position. The driveline travel must still be about 25mm (1 inch) in the maximum coupling (overlap) position.
2. Always couple the two end yokes of the driveline, check that they are locked in place. To achieve this condition, completely insert the latch pin into the groove in the PTO shaft on the tractor. Install the bolt through the yoke and input the shaft on the mixer. An unlocked shaft will slip out of position, causing notable mechanical damage and serious injury to anyone nearby. If the driveline is too long, it should be shortened in the following way:

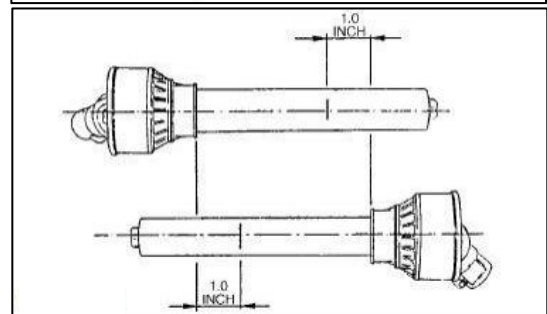
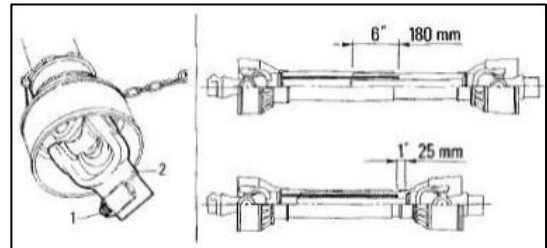

- Set the machine PTO input shaft at a minimum distance from the tractor PTO stub shaft, then set the tractor brakes, and switch the engine off.
- Separate the two halves of the driveline. Install the female part into the tractor PTO and the male part on the machine PTO, checking that the position is correct by means of the latch pin.
- Place the two halves of the driveline together, keeping them parallel. Using a felt-tip pen, mark the place where the two halves must be shortened, measuring 1.0 inch from the beginning of each half, as shown in Figure. Double check before making any cuts. Cut PTO drivelines cannot be returned.
- Raise and lower the Slasher to determine the position with the greatest distance between the PTO shaft and slasher input shaft. Shut the tractor off, leaving the slasher in the position of greatest distance between shafts. **SECURELY BLOCK THE SLASHER IN POSITION.**
- Hold the driveline sections parallel to each other and check for a minimum of 6" (15cm) overlap. If the driveline has been marked for cutting, the overlap will be the distance between the two marks. If the driveline has less than the minimum overlap, do not use it. Contact an authorized dealer.
- If the driveline must be cut to a shorter length, clamp it in a well-padded vise to prevent damage to the shield. Cut off the shield where it's marked. Using the removed sections of the shield as a guide, cut off the same amount from the shaft .
- Repeat the procedure on the other driveline half. Remove all burrs and cuttings.
- Apply multi-purpose grease to the inside of the outer (female) driveline section. Assemble the driveline and install on the tractor and the mixer. Pull on each driveline section to be sure the yokes lock into place. Make certain the driveline shielding is in place and in good condition.

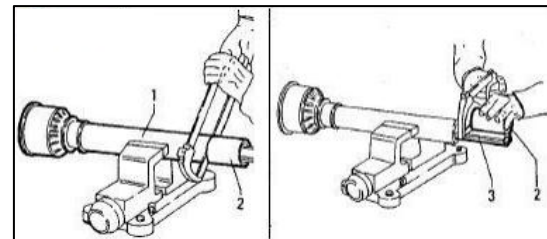

WARNING !

When attaching the PTO yoke to the tractor PTO shaft, it is important that spring-activated locking pins or balls operate freely and are seated in the groove on the PTO shaft. A loose shaft could slip off and result in personal injury or damage to equipment.

- Carefully raise and lower the mixer and check to be sure the PTO assembly does not jam . If it does, cut equal amounts from each half of the PTO assembly. If the PTO driveline assembly contacts the swinging drawbar, damage will occur to the driveshaft shield and possibly the driveshaft itself (NOT covered under warranty).
- Check the swinging drawbar of the tractor and make sure the PTO driveline assembly will not contact. The swinging drawbar can be moved forward on some tractors or it can be removed.

Note: This type of damage is NOT covered under warranty, as it is totally under the control and the responsibility of the operator.

PRIOR TO OPERATION

BEFORE PUTTING Slasher INTO SERVICE IMPORTANT INSTRUCTIONS PRIOR TO OPERATING MUST BE FOLLOWED.

SLASHER SHIPPED WITHOUT OIL IN GEAR BOXSAND WITHOUT GREASE IN GREASE FITTINGS. UNIT MUST BE SERVICED BEFORE USING.

Fill Gearbox using Multipurpose Gear Oil (85/140). For all Grease Fittings use a high-temp/multipurpose grease.

STEP1

Place Slasher so that the deck is secure and level.

STEP2

Remove the breather plug located at top of gearbox and plug /grub screw(located on the side or rear of the lower half of gearbox).

STEP3

Fill gearbox using multipurpose gear oil through top fill hole until gear oil is level with lower hole.

STEP4

Installation both the breather plug (located at top of gear box) and plug/grub screw (located at lower 1/2 of gearbox) and clean off any excess oil.

STEP5

Grease the following points:

- * Both Universal Joints and Safety Guard grease points on the PTO Shaft.
- * Grease points on the trail wheel.

STEP6

Inspect all guards to insure they are in good working order and properly secured. If not replace before using.

STEP7

Check all bolts and nuts to insure they are tight and secure.



CAUTION

DO NOT overfill gearbox. This could cause damage to oil seals and can cause permanent damage to the gearbox. Any defects or failures caused by overfilling will not be covered under warranty

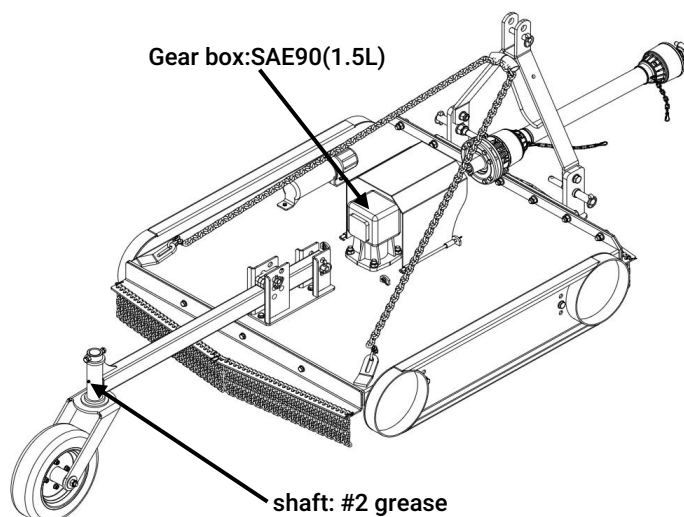

Preparation



Never operate the tractor and Slasher until you have read and completely understand this manual, the Tractor Operator's Manual and each of the messages found on the safety decals on the tractor and Slasher.

Personal protection equipment including hard hat, safety glasses, safety shoes, hearing protection and gloves are recommended during assembly, installation, operation, adjustment, maintenance, repairing, removal, or moving the implement. Do not wear loose fitting clothing or jewellery and be sure to contain long hair around equipment.

PROLONGEDEXPOSURETOLOUDNOISEMAYCAUSEFERMANENTHEARINGLOSS! Tractors with or without Slashers attached can often create enough noise to cause permanent hearing loss. We recommend that you use hearing protection at all times. Long-term exposure to noise levels over 80db can cause severe hearing loss. NOTE: Hearing loss from loud noises (from tractors, chain-saws, radios, and other sources close to the ear) is cumulative over a lifetime, with no chance of natural recovery.

Always wear your seat belt. Serious injury or even death could result from falling off the tractor particularly during a rollover when the operator could be trapped under the ROPS or the tractor.

Clear area to be cut of stones, branches and other debris that might be thrown causing injury or damage. Operate only in daylight. Do not operate Slasher in dry conditions as there is a risk of starting fires. Ensure Slasher is properly mounted, adjusted and in good operating condition.

Ensure that all safety guards and safety decals are properly installed and in good condition.

Starting and Stopping Safety



Check the tractor master guard over the PTO shaft. Make sure it is in good condition and fastened securely to the tractor. Purchase a new guard if old guard is damaged or missing.

All tractors that are not equipped with a "live" Power Take Off (PTO) need to be equipped with an over-running PTO clutch. These are available through most farm machinery dealers.

NOTE: The addition of an over-running PTO clutch may change the length of the PTO driveline required. Pay extra attention to the instructions on the PTO driveline installation refer page 19. Be sure that the driveline system guarding is sufficient.

Slasher operating power is supplied from the tractor PTO. Refer to your tractor manual for PTO engagement and disengagement instructions. Know how to stop the tractor and Slasher quickly in case of an emergency.

The engine RPM should always be at idle speed when engaging the PTO. Once engaged and you are ready to start cutting, increase the PTO speed to approximately 540 RPM and maintain throughout the cutting operation.

The use of this equipment is susceptible to certain hazards that cannot be protected against by mechanical means or product design. All operators of this equipment must read and understand this entire manual, paying particular attention to safety and operating instructions, prior to using.

Most accidents occur because of neglect or carelessness. Keep all assistants and bystanders one hundred meters from the operating Slasher. When machine is operated in populated areas where thrown objects could injure persons or property, operation must be stopped if anyone comes within one hundred meters.

The Slasher is designed for the use on tractors with 540-RPM power take off.



Install and secure all guards and shields before starting or operating. The discharge chute, flaps, chains, driveline guards and tractor guards should be used and maintained in good working condition. They should be inspected carefully daily for missing or broken cables, chain links, shields and guards. Worn items must be replaced at once to reduce the possibility of injury.

Disengage Power Take Off (PTO) and place tractor transmission in neutral before attempting to start engine.

Many varied objects, such as wire, cable, rope or chains can become entangled in the working parts of the Slasher. These objects could then swing outside the housing at a greater velocity than the blades. Such an occurrence is extremely hazardous. Inspect the cutting area for such objects before slashing. Remove any objects from the site.

Never allow the cutting blade to contact objects. Cut higher first, allowing Slasher to clear such hidden objects. Never assume an area is clear. Always check!

Always stop the tractor, disengage PTO, allow cutter blades to come to a complete stop, lower implement to the ground, set park brake, shut off the tractor engine and remove the ignition key before dismounting tractor. Never leave equipment unattended while the tractor is running.

Never place hands or feet under Slasher. Stay clear of all moving parts.

Do not reach or place any part of your body under the equipment until it is blocked securely.

Do not allow riders on the Slasher or tractor at any time. There is no safe place for riders.

Do not operate unless all personnel, livestock and pets are at least one hundred meters away to prevent injury by thrown objects. Never direct the discharge chute towards anyone.

Never operate tractor and Slasher under trees with low hanging limbs. Operators can be knocked off the tractor and then be run over by the Slasher.

The rotating parts of this machine have been designed and tested for rugged use. However, they could fail upon impact with heavy, solid objects such as steel, concrete, rocks or stumps. To reduce the possibility of property damage, serious injury or even death never allow the cutting blades to come in contact with such objects.

Stop Slasher and tractor immediately upon striking an obstruction. Turn engine off, remove key, engage park brake then inspect and repair any damage before resuming operation.

Stay alert for uneven terrain, holes, roots and other hidden hazards. Keep away from drop-offs and hazards that could cause roll-over. Use extreme caution and maintain minimum ground speed when transporting or operating on hillsides, over rough ground and when operating close to ditches or fences. Be careful and slow down when turning sharp corners and changing direction on slopes. Do not start or stop suddenly on slopes and avoid operating on steep slopes. In extremely uneven terrain, rear wheel weights, front tractor weights and / or tire ballast should be used to improve stability.

Drive Slasher diagonally over sharp dips and avoid sharp drops to prevent tractor and Slasher from "hanging up". Always cut downward on slopes, never cut across the face. Always check tractor manual for proper use on slopes. Practice will improve your skills in manoeuvring on rough terrain.

Transport Safety



Always observe state and local laws governing highway safety and the travel of farm machinery on public roads. When driving the tractor and equipment on roads or highways use flashing amber warning lights and a slow moving vehicle (SMV) identification emblem. Do not exceed 20kph. Reduce speed on rough roads and surfaces.

Plan your route to avoid heavy traffic.

Always install transport locks, pins or brackets before transporting.

Do not drink and drive.

Be a safe and courteous driver. Always yield to oncoming traffic in all circumstances, including narrow bridges, intersections etc. Watch for traffic when crossing or operating in close proximity to roadways.

Use extreme care and maintain minimum ground speed when operating close to ditches and or fences. Be careful when turning sharp corners. Never allow riders on either tractor or Slasher.

MAINTENANCE

The Cutting Height Adjustment

The cutting height can be set by lifting the slasher, undoing the bolts and nuts attaching the adjustable skids and repositioning the skid plates to the required height. When adjusting the skids, ensure the whole wear surface touches the ground to avoid uneven wear. Achieve this by adjusting the slasher attitude with the top link of the tractor. After adjusting the skids retighten the attaching bolts and nuts securely.



CAUTION: Disengage the PTO, stop the tractor engine and support the slasher on stands before adjusting the skid height.

Under heavy cutting conditions it is advantageous to set the rear of the slasher about 25mm higher than the front. This ensures that the material will only be cut once. If the slasher is lower at the rear the material will be cut a second time by the rear arc of the blades and will require considerably more power.

The Slasher Operation

Before starting to slash, check the area to be cleared to ensure that you are familiar with the ground conditions and that there are no dangerous hazards. This is especially important on land that has not been cut by you before, such as vacant blocks, sides of roads, channels and drains that can hold hazardous surprises.

Single Clutch

Tractors fitted with a single stage clutch will need an over-run clutch fitted in the PTO drive train. The slasher and tractor will begin moving at the same time. Once all safety procedures have been followed, start the tractor and raise the slasher approximately 200mm (6 inches) above the ground. Select the appropriate transmission gear and engage the 540 rpm PTO speed. Release the clutch and increase the engine revs to achieve 540 rpm at the PTO. Lower the slasher onto its skids to begin slashing. To minimize wear and tear on both tractor and slasher, the PTO speed should be maintained at 540 rpm. Lower speeds cause excessive wear, especially to blades and bolts, as the lower centrifugal force allows the blades to move on the bolts continuously.

If the slashing is very heavy and the tractor has difficulty handling it, take a narrower cut, which requires less power.

Stopping

Slow engine speed to idle and disengage the PTO shaft. Lower the slasher, switch off the tractor engine and apply the parking brake.

Maintenance Safety



Good maintenance is your responsibility.

- Follow good shop practices
- Keep service area clean and dry.
- Be sure electrical outlets and tools are properly grounded.
- Use adequate light for the job at hand.

Make sure there is ample ventilation. Never operate tractor engine in a closed building. The exhaust fumes may cause asphyxiation.

Before working on this machine, disengage the PTO, be certain all moving parts on attachments have come to a complete stop, shut off engine, set the park brakes and remove the ignition keys before attempting to perform maintenance.

Do not perform maintenance or work on the Slasher on uneven or sloping surfaces.

Never work under equipment unless Slasher is properly supported by blocks or stands under the body with appropriate approved weight capacity.

Always use personal protection devices such as eye, hand and hearing protectors when performing any service or maintenance.

Frequently tighten all bolts, nuts, screws and check to make certain unit is safe to operate.

When completing maintenance or service, make sure all safety guards and devices are installed before using the Slasher.

After servicing, be sure all tools, parts and service equipment are removed from the Slasher.

Do not allow debris, grease or oil to build up on any part of the deck or platform.

Where replacement parts are necessary for periodic maintenance and servicing, factory replacement parts must be used to restore your equipment to original specifications. Contact your local dealer replacement parts.

The manufacturer and / or distributor will not be responsible for injuries or damages caused by the use of unapproved parts and or accessories.

A first aid kit should be kept readily accessible while performing maintenance on this equipment.

Storage Safety



Following use, or when unhooking the Slasher, disengage the PTO, stop the tractor, set the park brakes, shut off the engine and remove the ignition keys.

Store the unit in an area away from human activity.

Do not park equipment where it can be exposed to direct contact with livestock for long periods of time. Damage to Slasher and or livestock could result. Make sure all parked machines are on a hard, level surface and that all safety devices are engaged.

Maintenance Schedule

Slasher recommends that the following routine service / maintenance schedule be followed to ensure the efficient and safe operation of your Slasher. If followed this maintenance schedule will maximise the working life of the Slasher.

PRIOR TO FIRST USE OF SLASHER

1. Check all bolts and nuts are tightened correctly
2. Check all hitch pins are securely locked
3. Check Bow Shackles on drag chains are tight
4. Ensure Quick Coupler Pins on the PTO shaft are secured correctly to both the Slip Clutch (Slasher end) and to the tractor PTO output shaft
5. Ensure slip clutch is set correctly
6. Check gearbox oil level. Add oil if required
7. Check PTO shaft has been greased as per instructions listed on next page.

AFTER EVERY EIGHT HOURS OF OPERATION

1. Grease PTO shaft as per instructions listed on bottom of next page.
2. Check Cutter Beam for any signs of damage and check Retaining Nut to gearbox is tight and split pin is still in place.
3. Check blades for signs of damage or excessive wear. Replace if necessary.
4. Ensure blade retaining plough bolts and self locking nuts are not damaged and are tight.
5. Check Clutch settings and make adjustments if necessary.
6. Check for any debris from cutting or items such as wire are not built up around gearbox output shaft and cutter beam.
7. Clean Slasher deck and remove any cuttings or other debris that has built up on the Slasher. In heavy slashing conditions cuttings may need to be cleared from the deck more frequently.

AFTER EVERY 40 HOURS OF OPERATION

1. Complete all processes as per eight hour service
2. Check all bolts and nuts are tightened correctly
3. Check all hitch pins are securely locked
4. Check Bow Shackles on drag chains are tight
5. Check PTO shaft universal joints for any signs of wear. Replace any worn components if required.

ANNUAL MAINTENANCE

1. Thoroughly clean the Slasher of mud and grass.
2. Drain the gearbox and clean it thoroughly. Fill with new gear oil up to the dedicated oil level.
3. Check and clean blade axles. Replace oil seals and grease them.
4. Check all blades, replace then if they are worn out or damaged.
5. Repair the side skirts; return them to original technical condition. Replace damaged or broken protective devices.
6. Remove the drive shaft from the machine. Pull the PTO shaft apart. Check and replace any components that are damaged or worn. Install the PTO shaft on the machine. The PTO shaft should telescope easily and the guard turn freely on the shaft

	8hrs/ Daily			40hrs/Weekly			Annually		
Lubricate PTO Shaft	✓			✓			✓		
Lubricate Jockey Wheels	✓			✓			✓		
Lubricate Blade Spindle	✓			✓			✓		
Check Gear Box Oil Level				✓			✓		
Clean Machine							✓		
Lubricate and Clean PTO Shaft Cover							✓		

PTO Shaft Maintenance

The PTO shaft is designed to telescope to allow for dimensional changes as the machine goes through its operating range. A tubular guard encloses the driving components and is designed to remain stationary on a turning shaft when required. The shaft should telescope easily and the guard turn freely on the shaft at all times. Annual disassembly, cleaning and lubrication is recommended to insure that all components function as intended. To maintain the shaft, follow this procedure:

1. Remove the shaft from the machine.
2. Pull shaft apart.
3. Use a screwdriver to pry the tabs out of the sleeves on each end. There are 3 tabs per guard.
4. Pull the shaft out of the plastic tubular guard.
5. Use a solvent to clean the male and female portions of the telescoping ends.
6. Apply a light coat of grease to each end.
7. Clean grooves on each end where the tabs are located. Clean each tab also.
8. Apply a light coat of grease to each groove.
9. Insert the shaft into its respective guard and align the slots with the groove.
10. Insert the tabs through the slots and seat in the groove.
11. Check that each guard turns freely on the shaft.
12. Assemble the shaft.
13. Check that the shaft telescopes easily.
14. Replace any components that are damaged or worn.
15. Install the shaft on the machine.

Gearbox Maintenance

The gearbox used on the Slasher will give many years of trouble-free service with minimal maintenance requirements. Maintain the gearbox by following this procedure:

Oil level:

- Remove the level plug from the rear or side of the gearbox.
- Add oil through the filler plug located on top of gearbox until oil comes out of level plug.
- Add through the fill plug if required.
- If gearbox has a dipstick on filler plug, then fill to indicator mark.

IMPORTANT: Check the oil level only when the unit is cold and the machine is on the level.

Replacing Blades

It is recommended that whenever blades require replacing on a Slasher the following components also be replaced. Blade retainer bolts, nylock nuts, washers, bolts must be tightened to 350 ft./lb. These are listed in the Parts List on pages 32-33 of this Manual. Specifications are also detailed and must be replaced using genuine parts. Please contact your local dealer for any parts required.

STORAGE

After the season's use, the machine should be thoroughly inspected and prepared for storage. Repair or replace any worn or damaged components to prevent any unnecessary down time at the start of next season. To insure a long, trouble free life, follow the procedure outlined below:

1. Thoroughly wash the machine using a pressure washer to remove all dirt, mud, debris and residue.
2. Inspect the blades and rotor for damage or entangled material. Repair or replace damaged parts. Remove all entangled material.
3. Lubricate all grease nipples. Make sure that all grease cavities have been filled with grease to remove any water residue from the inside.
4. Touch up all paint nicks and scratches to prevent rusting.
5. Move to storage area.
6. Select an area that is dry, level and free of debris.
7. Unhook from tractor .
8. If the machine cannot be placed inside, cover with a waterproof tarpaulin and tie securely in place.

Store the machine in an area away from human activity. Do not allow children to play on or around the stored machine.

TROUBLESHOOTING

PROBLEM	PROBABLE CAUSE	SOLUTION
Leaves a streak of uncut or partially cut grass	<ol style="list-style-type: none"> 1. Slasher not level side to side 2. Blades dull or bent 3. Carrier speed too low 4. Field conditions are so wet that the tractor tire is pushing grass into mud. 5. Ground speed too fast 6. Blades lock back 7. Blades riding up due to blade bolt wear. 8. Grass is laying down from previous weather conditions. 9. Possible build up of material under Slasher 10. Weed and grass stems are pushed down by the tractor tires and do not rebound up so they can be cut 	<ul style="list-style-type: none"> --- Level 3pt. hitch linkage on tractor --- Sharpen or replace blades --- Use correct PTO speed --- Too wet to slash. Stop operation and wait for drier conditions --- Reduce ground speed by shifting to a lower gear --- Free blades --- Replace blade bolts and hardened bushes' --- Slash in only one direction --- Clean Slasher --- Slash back and forth with enough overlap to slash tire track of previous cut again
Grass cut lower in centre swath than at edge	Height of Slasher lower at rear of front.	--- Adjust Slasher height and attitude so that Slasher rear and front are within 1/2" of same height
Gearbox overheating	<ol style="list-style-type: none"> 1. Low on lubricant 2. Improper type of lubricant 3. Excessive debris build-up 	<ul style="list-style-type: none"> --- Fill to proper level --- Replace with proper lubricant --- Remove debris around gearbox
Blade is scalping ground	<ol style="list-style-type: none"> 1. Slasher too low 2. Field is too ridged 3. Field is too wet 	<ul style="list-style-type: none"> --- Raise Slasher and 3pt.control stop --- Cut field at a different angle --- Stop and wait until it is drier
Slasher will not cut all the time	Slip clutch is slipping	--- Adjust slip clutch according to instructions
PTO contacts Slasher front frame when raised	Raising Slasher too high or incorrect adjustment of tractor top link	--- Adjust top link or tractor lift stops
Blade bolts come loose	<ol style="list-style-type: none"> 1. Bolts not tightened 2. Bolt hole elongated or oversized 3. Blade bolt threads are worn or damaged 	<ul style="list-style-type: none"> --- Tighten bolts to 350 ft./lb --- Replace blade carrier --- Replace blade bolt, washer, nylock nut and hardened bush

PROBLEM	PROBABLE CAUSE	SOLUTION
Blade wears too fast	<ol style="list-style-type: none"> 1. Cutting in sandy conditions 2. Cutting in rocky conditions 3. Blades hitting ground 	<ul style="list-style-type: none"> --- Increase cutting height --- Increase cutting height --- Increase cutting height
Slasher seems to require excessive power	<ol style="list-style-type: none"> 1. Advancing into grass or bush too rapidly 2. Hitting ground 3. Worn or dull blades 4. Tractor not large enough 	<ul style="list-style-type: none"> --- Reduce forward travel speed --- Raise Slasher --- Replace blades --- Use higher horsepower tractor
Gearbox noisy	<ol style="list-style-type: none"> 1. Rough gears 2. Worn bearings 3. Low oil in gearbox 	<ul style="list-style-type: none"> --- Run in or change gears --- Replace bearing --- Check level and add oil
Gearbox leaking	<ol style="list-style-type: none"> 1. Damaged oil seal 2. Bent shaft 3. Shaft rough on oil seal area 4. Oil seal installed incorrectly 5. Oil seal not sealing in the housing 6. Oil level too high 7. Hole in gearbox 8. Gasket damaged 9. Bolts loose 	<ul style="list-style-type: none"> --- Replace seal --- Replace oil seal and shaft --- Replace or repair shaft --- Replace seal and install correctly --- Replace seal or use a sealant on outside diameter of seal --- Drain oil to proper level --- Replace gearbox --- Replace gasket --- Tighten bolts
Excessive vibration	<ol style="list-style-type: none"> 1. Check gearbox bolts 2. Check for loose nuts on all components 3. Check for bent output shaft, oil will normally leak from bottom seal 4. Check to see if blades are free-swinging 5. Check for even wear on each blade tip. Were both blades changed at the same time? 6. Blade broken 7. Blade beam bent or damaged 8. New blade or bolts matched with worn blade or bolts 9. Drivelines not phased correctly implement and tractor yokes must be in line 10. Wire or rope wrapped around blade beam 11. Blades worn and are out of balance 	<ul style="list-style-type: none"> --- Tighten if loose --- Tighten if loose --- Replace shaft if bent --- Free blades so they swing --- Weight blades. Weight should be within 30grams. Always replace both blades --- Replace blades in sets --- Replace blades beam --- Replace blades and bolts in sets --- Replace driveline --- Remove wire or rope --- Replace blades in sets
Front hitch "A" frame bending sideways	<ol style="list-style-type: none"> 1. Operator turning sharply hitting objects with trail wheel frame or Slasher deck 2. Slasher is being operated too low and Slasher is contacting ground during turns 3. Tractor 3pt. hitch leaking / creeping down and Slasher deck is contacting ground 	<ul style="list-style-type: none"> --- Drive carefully and plan turns to avoid hitting buildings, posts, trees etc. --- A. Raise Slasher (especially on rough ground) B. Set stop on hitch controls lever so hitch lift arms do not drop Slasher o ground --- A. Repair tractor hitch hydraulic system B. Use limit chains to keep arms from going lower than set limit

EXPLODED VIEW & PARTS LIST

1. Main-frame assembly

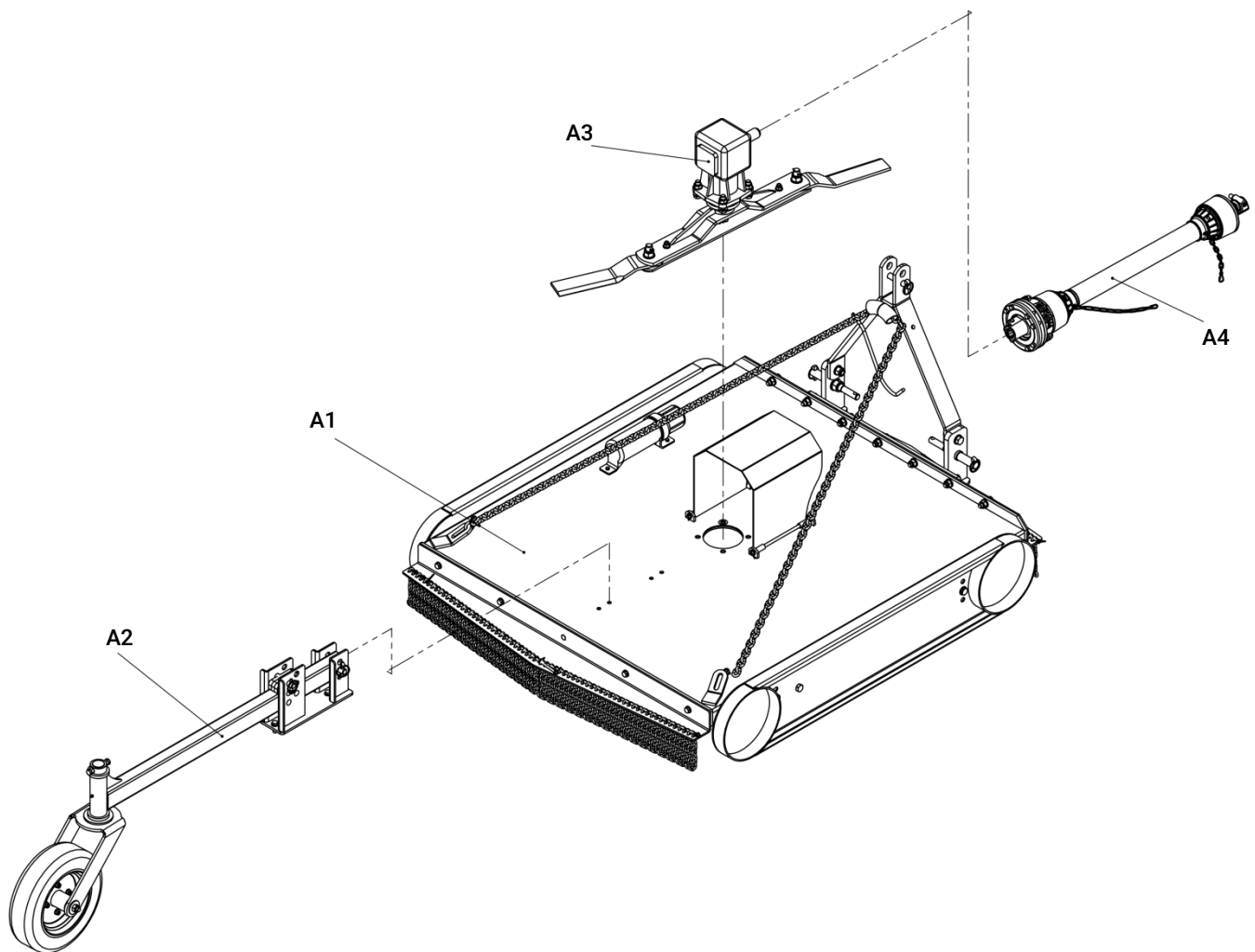

PARTS LIST

PART NO.	DESCRIPTION	QTY
A1	Host assembly	1
A2	Tailing wheel assembly	1
A3	Cutter assembly	1
A4	PTO shaft	1

2. Host assembly

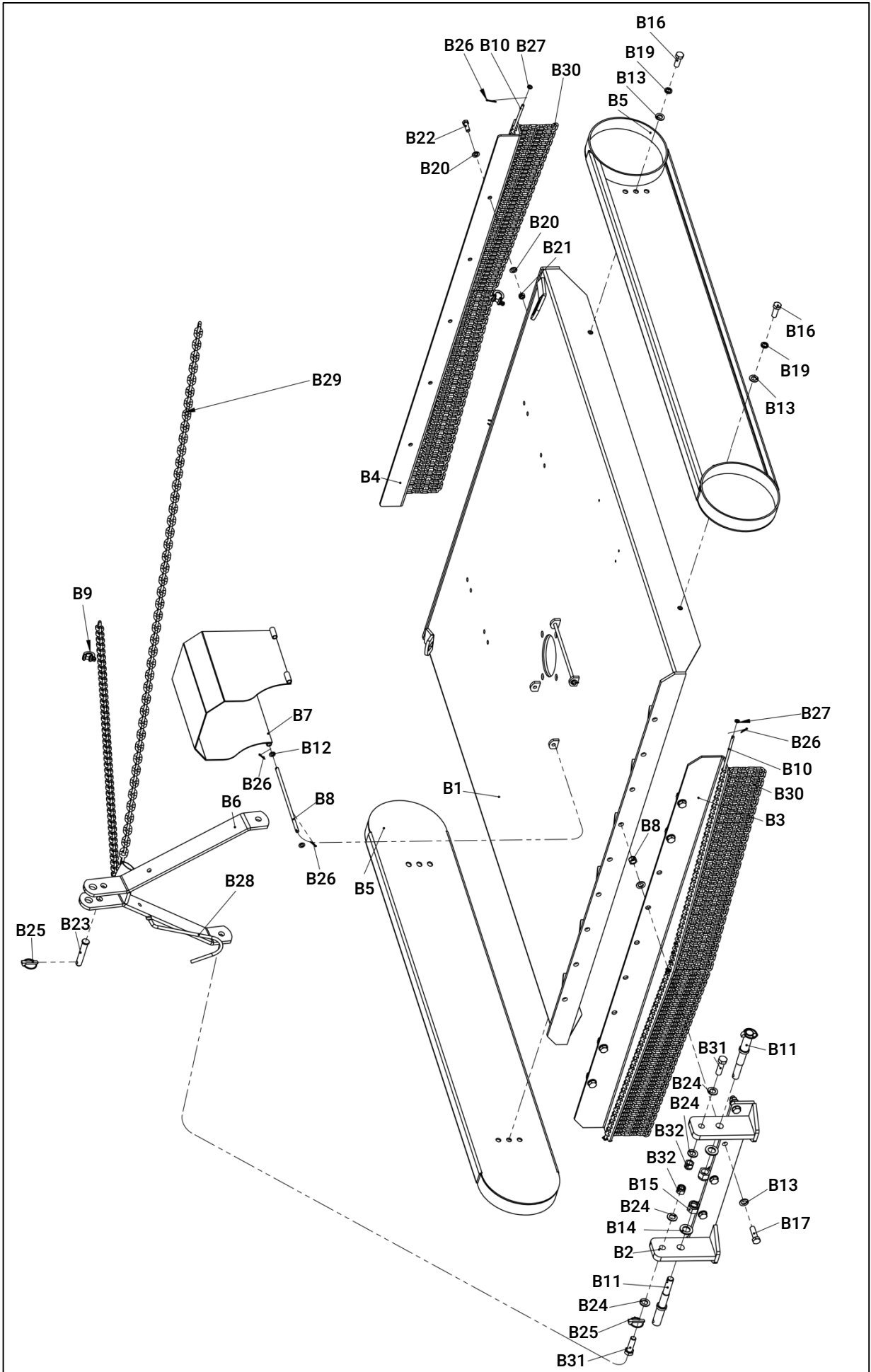

PARTS LIST

PART NO.	DESCRIPTION	QTY	PART NO.	DESCRIPTION	QTY
B1	Bottom Plate Weldment	1	B17	Full-thread hexagon bolts M16X55	5
B2	Conector Plate Weldment	1	B18	Locknut M16	7
B3	Front Chain Plate	1	B19	Spring washer Ø16	4
B4	Rear Chain Plate	1	B20	Plain washer Ø12	7
B5	Slide Plate Weldment	2	B21	Locknut M12	4
B6	Suspension Weldment	1	B22	Full-thread hexagon bolts M12x35	3
B7	Gear Cover Weldment	1	B23	Pin MT9503	1
B8	Connector Pin	2	B24	Plain washer Ø8	4
B9	Lock accessories	2	B25	Pin Ø12	3
B10	Chain Axle	4	B26	Split pin	12
B11	Low Pin	2	B27	Plain washer Ø18	8
B12	Plain washer Ø10	4	B28	Hook	1
B13	Plain washer Ø16	18	B29	Lifting chain 8x8x24	1
B14	Plain washer Ø24	2	B30	Galvanized chain 6x8x21	2
B15	Locknut (fine pitch) M24x28	2	B31	Full-thread hexagon bolts M18x60	2
B16	Full-thread hexagon bolts M16x45	6	B32	Locknut M18	2

3. Tailing wheel assembly

PARTS LIST

PART NO.	DESCRIPTION	QTY	PART NO.	DESCRIPTION	QTY
C1	Solid rubber wheel 450-8	1	C13	Plain washer Ø12	8
C2	Large plain washer Ø16	2	C14	Full-thread hexagon bolts M12x35	4
C3	Plain washer Ø10	8	C15	Locknut M12	4
C4	Full-thread hexagon bolts M10x35	4	C16	Tail wheel bar	1
C5	Locknut M10	4	C17	Tail wheel aircraft	1
C6	Full-thread hexagon bolts M12x30	2	C18	Last axle sets of welding parts	1
C7	Tail wheel plate weldment	1	C19	Spacer bush	2
C8	Pin 8	2	C20	Tail wheel bolts M16	1
C9	Hexagon nuts M12	2	C21	Deep spacer bush	1
C10	Grease nipple M6	1	C22	Fixed sleeve	1
C11	Deep groove ball bearing	2	C23	Wheel connection pin	2
C12	Locknut M16	2	C24	Wheel plain washer	1

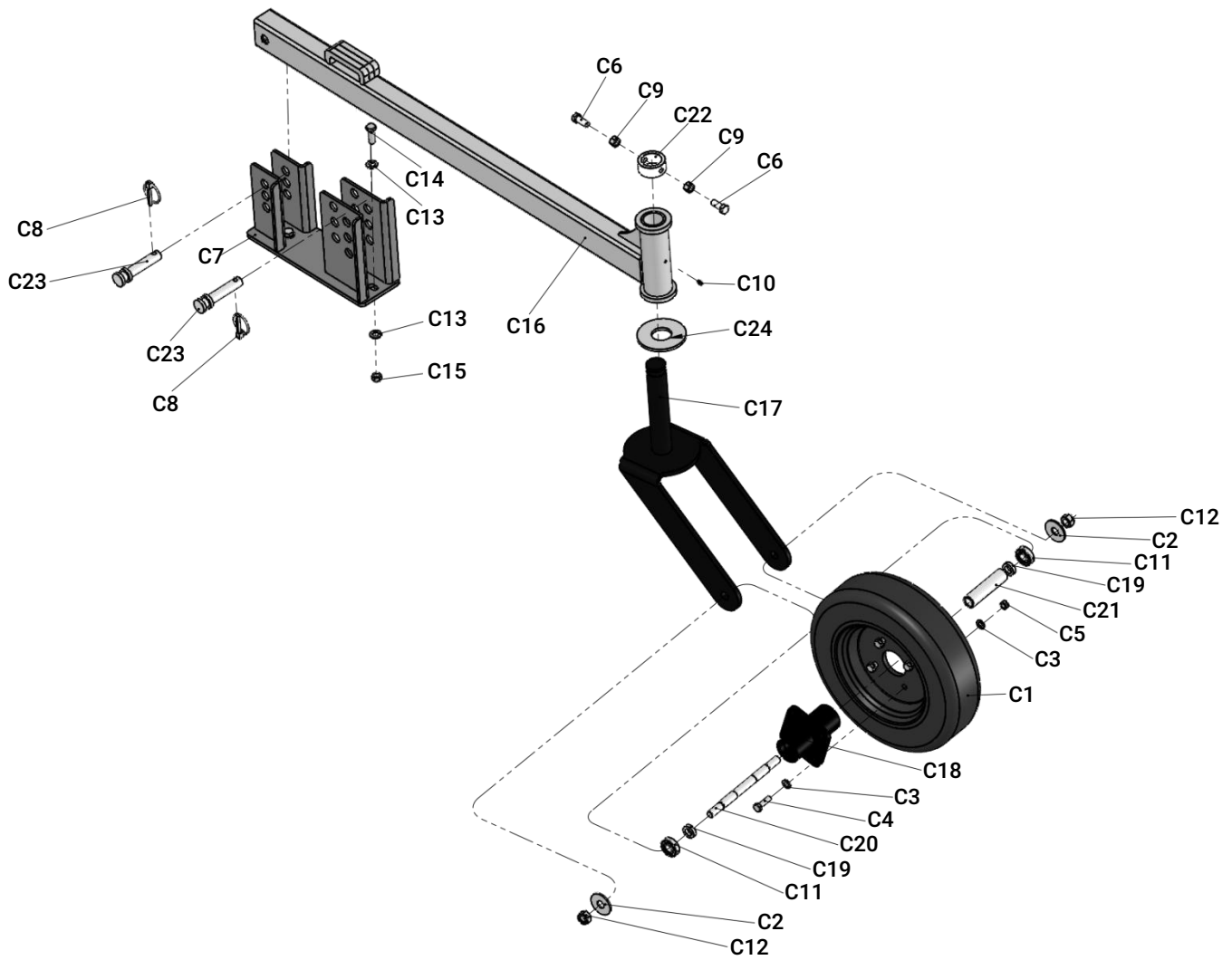

4. Cutter assembly

PARTS LIST

PART NO.	DESCRIPTION	QTY	PART NO.	DESCRIPTION	QTY
D1	Gear box 40HP	1	D10	Full-thread hexagon bolts M12x55	2
D2	Locknut M16	4	D11	Hexagon slotted and castle nuts	1
D3	Plain washer Ø16	8	D12	Split pin 5x35	2
D4	Full-thread hexagon bolts M16x55	4	D13	Locknut M22	2
D5	Split pin 5x40	1	D14	Plain washer Ø22	2
D6	Locknut M12	2	D15	Blade	2
D7	Plain washer Ø12	4	D16	Spacer	2
D8	Blade weldment	1	D17	Blade seat pad welding	1
D9	Flat washer	2	D18	Full-thread hexagon bolts M22x75	2

