

MODEL TMG-TSB65

65" 3-POINT TRACTOR STONE BURIER

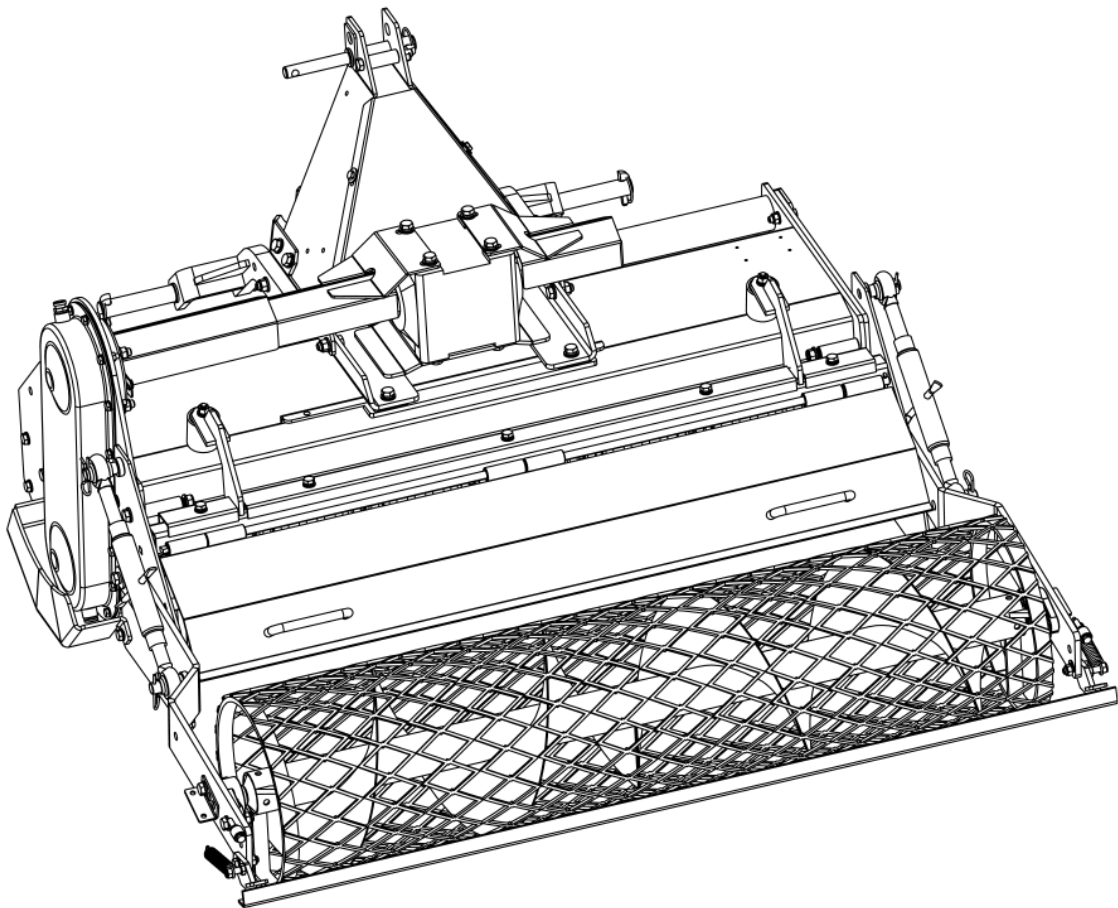

⚠ WARNING

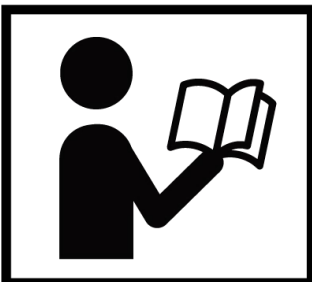

- Please read and understand the product manual completely before assembly
- Check against the parts list to make sure all parts are received
- Wear proper safety goggles or other protective gears while in assembly
- Do not return the product to dealer. They are not equipped to handle your requests.

Missing parts or questions on assembly?

Please call: 1-877-761-2819 or email: cs@tmgindustrial.com

TABLE OF CONTENTS

SAFETY INSTRUCTIONS	3
OPERATING SAFETY	4
PARTS DESCRIPTION AND FUCTION.....	7
PRODUCTS SPECIFICATIONS.....	9
UNPACKING & ASSEMBLY	10
CONNECTING TRACTOR	17
CHECK BEFORE OPERATING.....	22
LUBRICATION POINTS SUMMARY	23
OPERATING ESSENTIALS	24
OPERATION FINISH	25
MAINTENANCE SCHEDULE	25
TROUBLESHOOTING.....	26
PRODUCT PARTS LIST	27

SAFETY INSTRUCTIONS



Before operating the ROTARY TILLER read the following safety instructions. Failure to comply with these warnings may result in serious injury or death.

WARNING DECALS

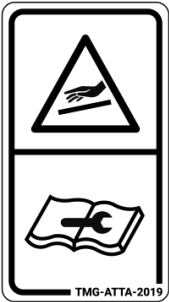

Warning!
Read and understand the operator manual completely before operating your rotary tiller.

CAUTION
FILL GEARBOX WITH SAE 90 GEAR LUBE
Gearbox is shipped without oil. Oil must be added before operation.
TMG-ATTA-2023

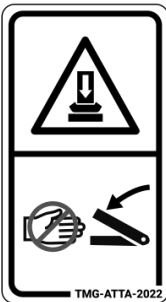

Caution!
Keep hand, feet, hair and clothing away from all moving parts.



Caution!
Keep all bystanders a safe distance away from machine and tractor.



Caution!
Before connecting the tractor, make sure that the speed of the tractor is correct. If the speed is incorrect, the machine may be damaged or human casualties may occur



Caution!
Keep the driving part of the machine lubricated

OPERATING SAFETY



Failure to comply with these warnings may result in serious injury or death!



Read and understand the operator manual before operating, servicing, adjusting, repairing or removing.

Operating before

Warning

Read the instruction before operation

Failure to understand warning or caution completely may result in injury before operation.

Warning

Ensure the instruction is placed around the machine

Don't operate especially for you don't know how to operate and the instruction is not around.

Warning

Don't operate as following conditions

It may result in accidents when your body is uncomfortable or not familiar with the machine.

- Don't operate as following conditions
- You can't concentrate to operate because of over fatigue, sick, under the influence of drugs and other reasons.
- After drinking.
- Operator who is unskilled.
- Pregnant women and minors.

Warning

Select the appropriate clothing

The uncomfortable clothing worn by operator will result in serious injury or death.

Please operate according to a hint of clothing

- Not wear a big jacket and trousers
- The sleeves and hems cannot too big.
- Wear safety helmets
- Don't wear in headscarf or towel .

Warning

Lend out the machine

It's very important to give operating instructions to the borrowers and advise detailed information of warning decals and operating notes.

Warning

Not allow machine modification

Unauthorized modification with device and component of other companies may weaken the function and/or safety and could affect the life of the equipment. Please select and use genuine parts as per the following part list.

⚠ Warning

Machine start and starting

- Ensure that the rotary hoe is connected to the tractor by three-point linkage.
- Ensure that the tractor is in neutral when it is started. Otherwise will cause the machine out of control and accidents.
- Ensure that PTO is cut off then start engine.
- Otherwise will injure bystanders.
- The tractor head maybe tilt and driver fall as well as injure bystanders when machine start under the high speed gear condition. Please ensure the surrounding is safe, then start machine under the lower speed gear condition and forward.
- Keep the ventilation when start tractor indoors, otherwise tractor exhaust may cause poisoning.

⚠ Warning

Tractor mounting operation

- Keep others away from machine and tractor when it is running or operating.
- Carry out tractor mounting operation on a flat or hard ground.
- Install moderate amount of weight loading according to tractor model and keep a stable center of gravity prior to carry out tractor mounting operation.

⚠ Warning

PTO using

- Don't use PTO without plastic cover shell, or you will be involved in and get injured.
- Cut the engine when dismantle the PTO
- Make sure to fix the plastic casing of chain, or you will be involved in and get injured
- Turn to page 13 to see the specific requirements of PTO.

⚠ Warning

- Ensure to connect on the left and right brake pedal when working machines moving.
- The driver and people around will be injured if others on the tractor fall off.
- Emergency braking and turning are forbidden.
- Turning until keep the safe distance between people and blocks.
- Move slowly on the ramps and uneven road.
- Use suitable backing board on the terrain with big drop.
- Do not carry people and luggage on the working machine.
- Ensure to cut off the PTO engine when moving.

During operation

⚠ Danger

- Stay away from the machine during operation, or you will be injured.
- Operate abide the specified speed, or the PTO will be damaged and people will be injured.
- Do not carry people and luggage on the working machine. .
- Shift down before into the ramps. High-speed moving on the ramps will slip.
- Concentrate during operation.
- Stay away from the machine.
- Do not close to the bevel, the inclined plane operation will cause the tractor turn over, so slow down the moving and operation speed.
- Cut off the PTO engine and stop the tractor when adjust the machine and remove the debris.
- Park the tractor on the flat field. Cut off the engine after the machine down to the ground.

After Operating

⚠ Warning

Make sure to cut off the PTO and tractor engine before cleaning.

⚠ Warning

- The problems of the machine will not be found if regardless of the inspection unit after operation. Inspection unit carefully according to the operating instruction.
- When using 3-point suspension to raise the machine to do the inspection, the machine will drop without attention. Do the inspection after locking the oil way of the 3-point suspension.

⚠ Warning

Bad treatment, Inspection unit, repair

- Maintenance according to the operating instruction, or the machine will be damaged.
- Working with the tractor on the flat and hard field.
- Cut off the PTO engine and stop the tractor when adjust the machine and remove the debris.
- Make the rack and ancillary shoring before drilling in.
- Repair and change the hydraulic joint and hose in time in the condition of without pressure in the original hose.
- The dismantle protective components in order to treat bad, instruction unit and repair should install back. Or they will be involved in the machine and cause the accident.

PARTS DESCRIPTION AND FUNCTION

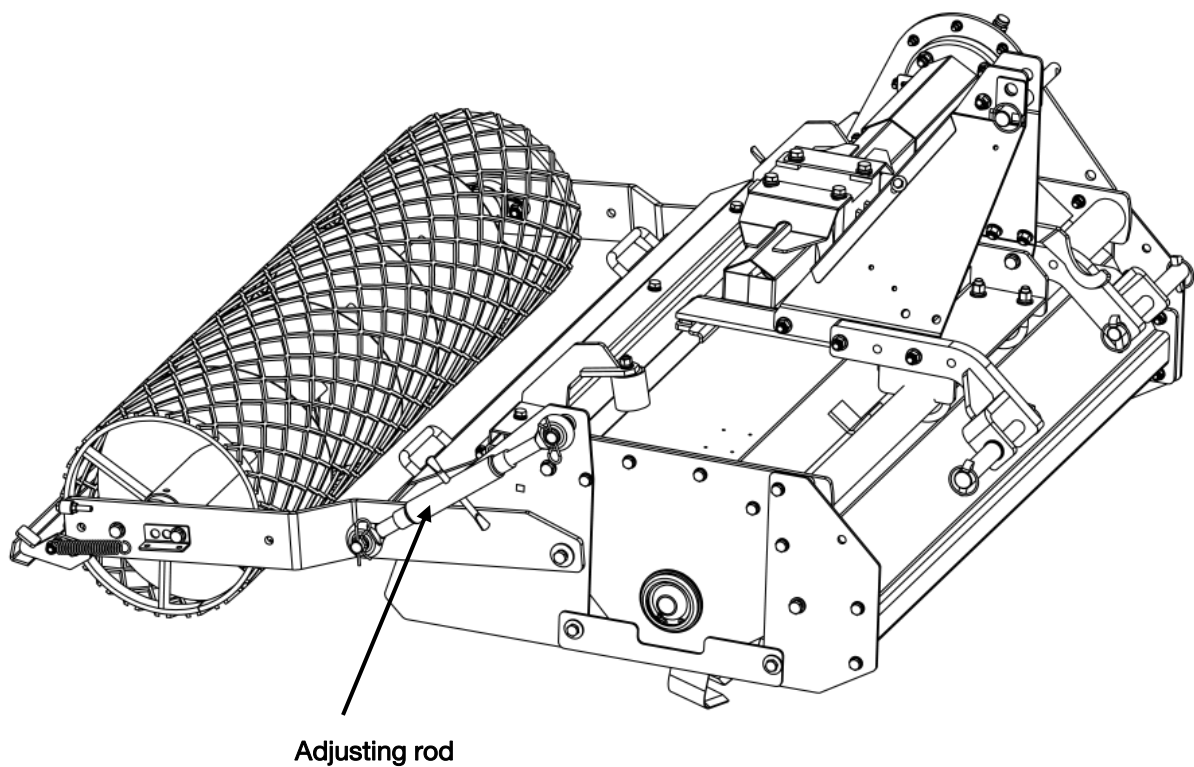
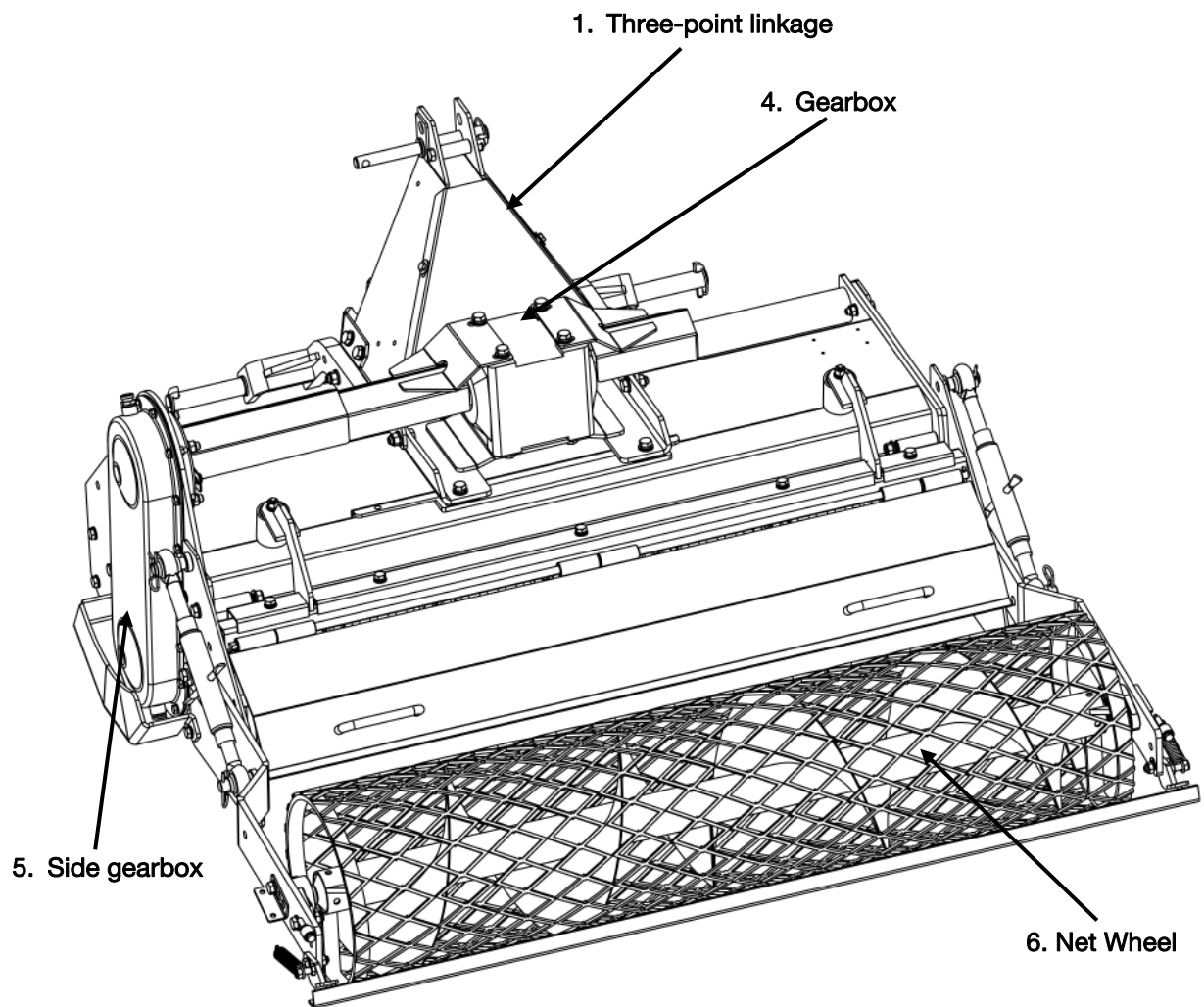

1. Three-point linkage

Connect tractor and rotary tiller

2. R&L blade

To tilling

3. Blade axle

Drive blade to rotate.

4. Gearbox

Change the output speed of the tractor and transmit power to the side gearbox.

5. Side gearbox

Through the driver chain transmit power from gearbox to the blade axle.

6. Net wheel

To work on the land

Blade axle assembly

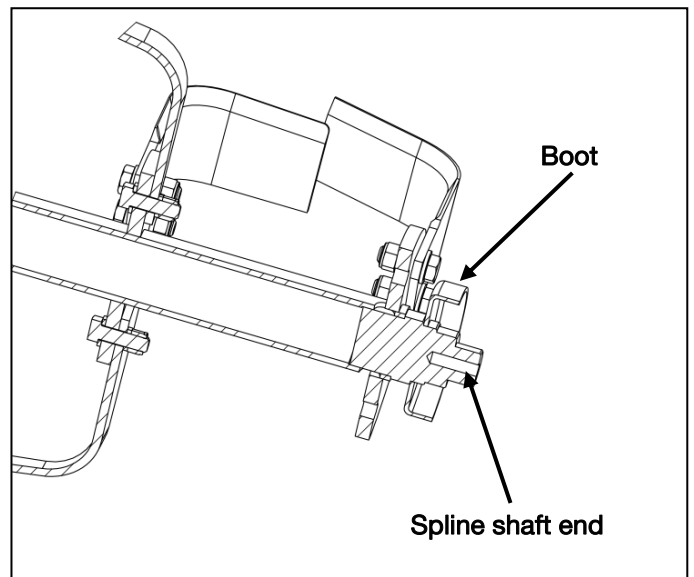
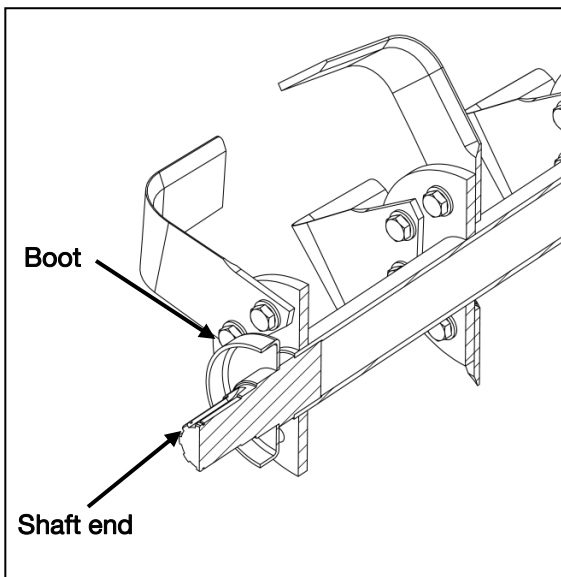
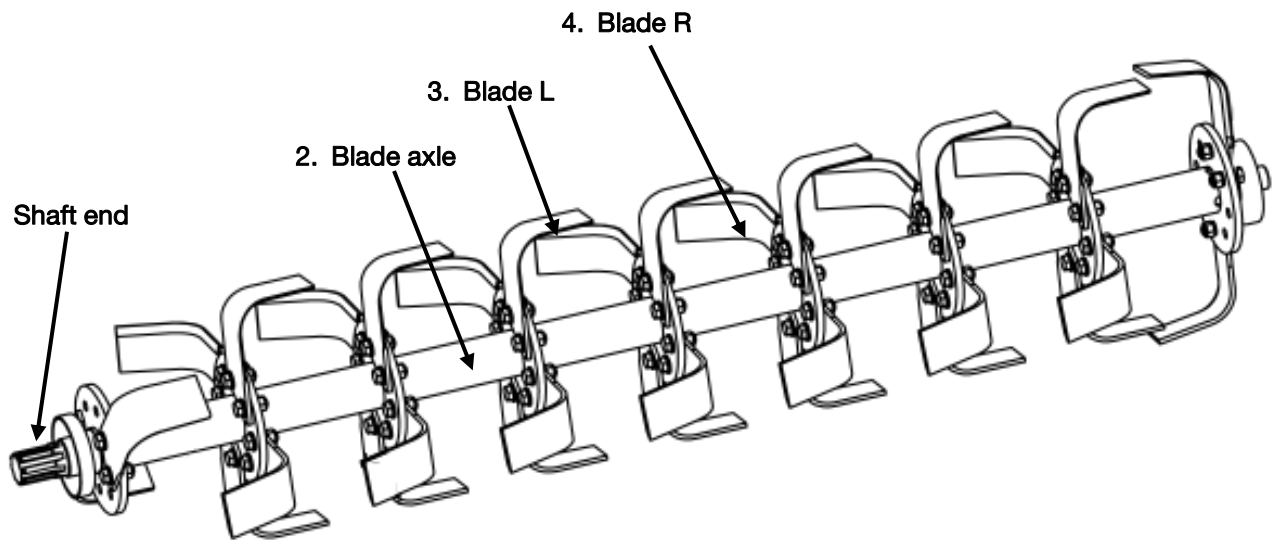

(1) Check

Check the appearance of partial assembly and ensure whether it has flaw and damage, blade edge curl. If has, just replace it.

(2) Assembly parts list

Ensure all parts without loss according to the explosive view.

(3) Assemble shaft end, spline shaft end, boot and blade

Install parts following the order from left to right or right to left, tighten bolt and nut. The both sides of shaft end are installed priority then the blade.

PRODUCTS SPECIFICATIONS

Model No.	TMG-TSB65
Working width	65"
Tilling depth	4.75"
Blade quantity	32
Rotary flanges	9
Stone diameter	2.5"
PTO rotary speed	540RPM
Rotary shaft speed	208RPM
Tractor power	35-55HP
Type of drive	Chain drive
Shipping Weight	890 lb
Shipping Size	71" x42" x29"

UNPACKING & ASSEMBLY

1. After unpacking, check the following components

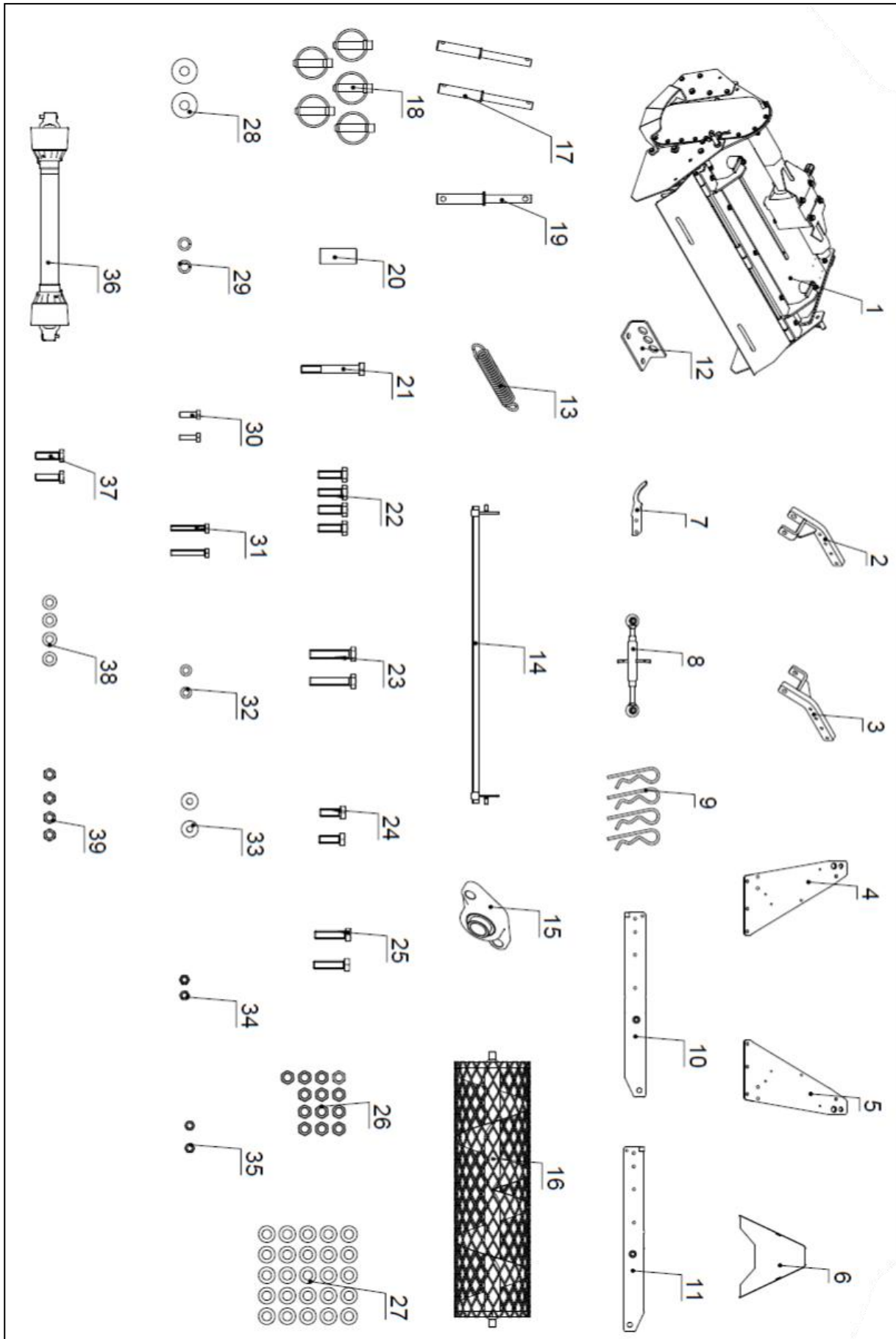

* All numbers are not part numbers in the drawings. For correct part numbers, see explosive diagram.

No.	Description	Qty	No.	Description	Qty
1	Host	1	21	Hexagon bolts M12*85	1
2	Extend the lower hanging Weldment (left)	1	22	Hexagon bolts M12*35	4
3	Extend the lower hanging weldment (right)	1	23	Hexagon bolts M12*60	2
4	Left suspension plate weldment	1	24	Hexagon bolts M12*30	2
5	Right suspension plate weldment	1	25	Hexagon bolts M12*45	6
6	Suspension rear connecting plate	1	26	Lock nut M12	13
7	Drive shaft placement plate	1	27	Flat washer Ø12	25
8	Adjust Tie Rod Assembly	2	28	Large washer Ø12	2
9	R pin	4	29	Spring washer Ø12	2
10	Welding parts of left connecting arm of net wheel	1	30	Hexagon bolts M8*25	2
11	Welding parts of the right connecting arm of the mesh wheel	1	31	Hexagon bolts M8*50	2
12	Hexagon bolts M14*45	2	32	Flat washer Ø8	2
13	Spring pull plate	2	33	Large washer Ø8	2
14	Scraper welding Parts	1	34	Lock nut M8	2
15	Outer spherical ball bearing with seat	2	35	Ordinary nut M8	2
16	Welded parts of mesh wheel	1	36	PTO drive shaft	1
17	Lower hanging pin	2	37	Hexagon bolts M10*35	2
18	Lock pin	5	38	Flat washer Ø10	4
19	Upper hanging pin	1	39	Lock nut M10	4
20	Upper hanging spacer	1			

2. Installation of the roller assembly

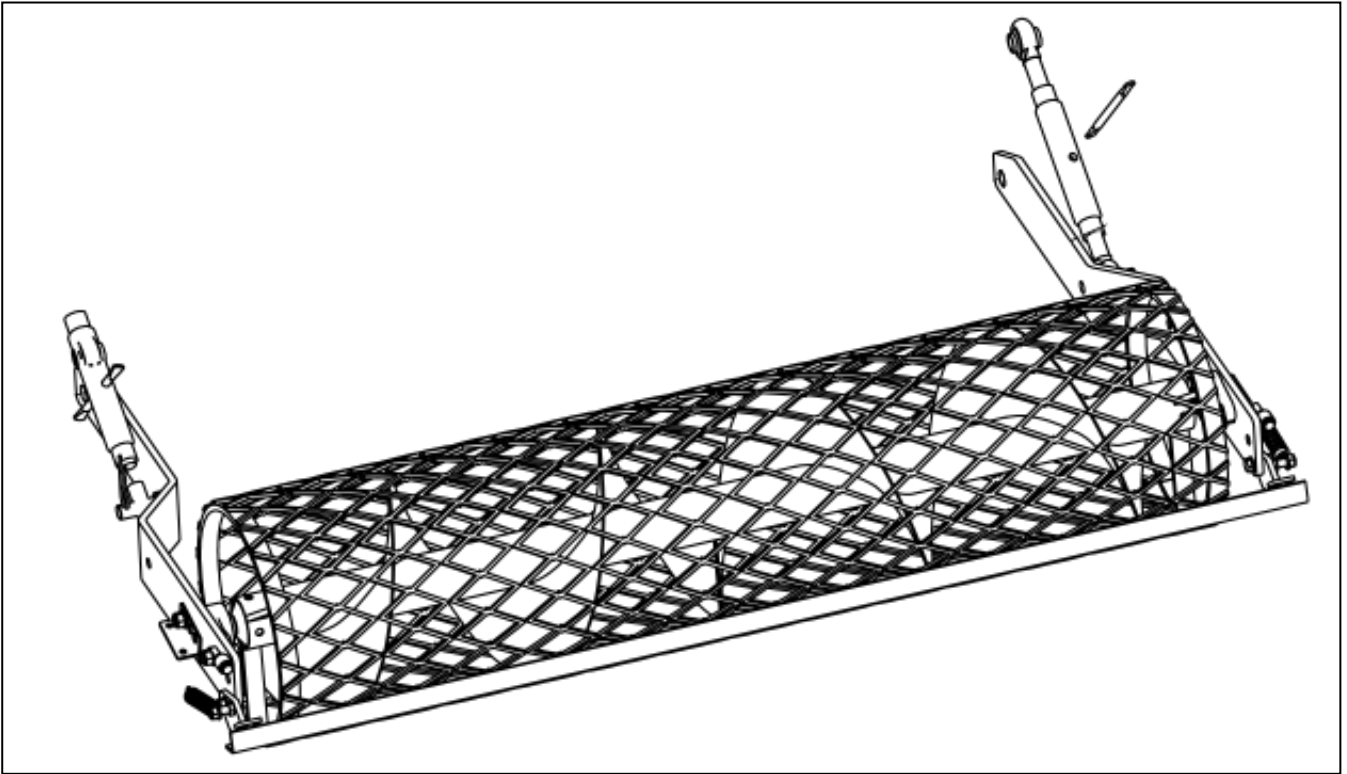

Installation steps:

1. First install the 2 outer spherical ball bearings with seats (E1) on the shaft of the mesh wheel welding part (E9), and then use bolts(E5), washers(E3) and lock nuts(E4) to fasten the spring pull plate (E2) and the left and right connecting arms (E11,E12) of the mesh wheel according to the pattern shown in the figure below. pull plate installation direction.

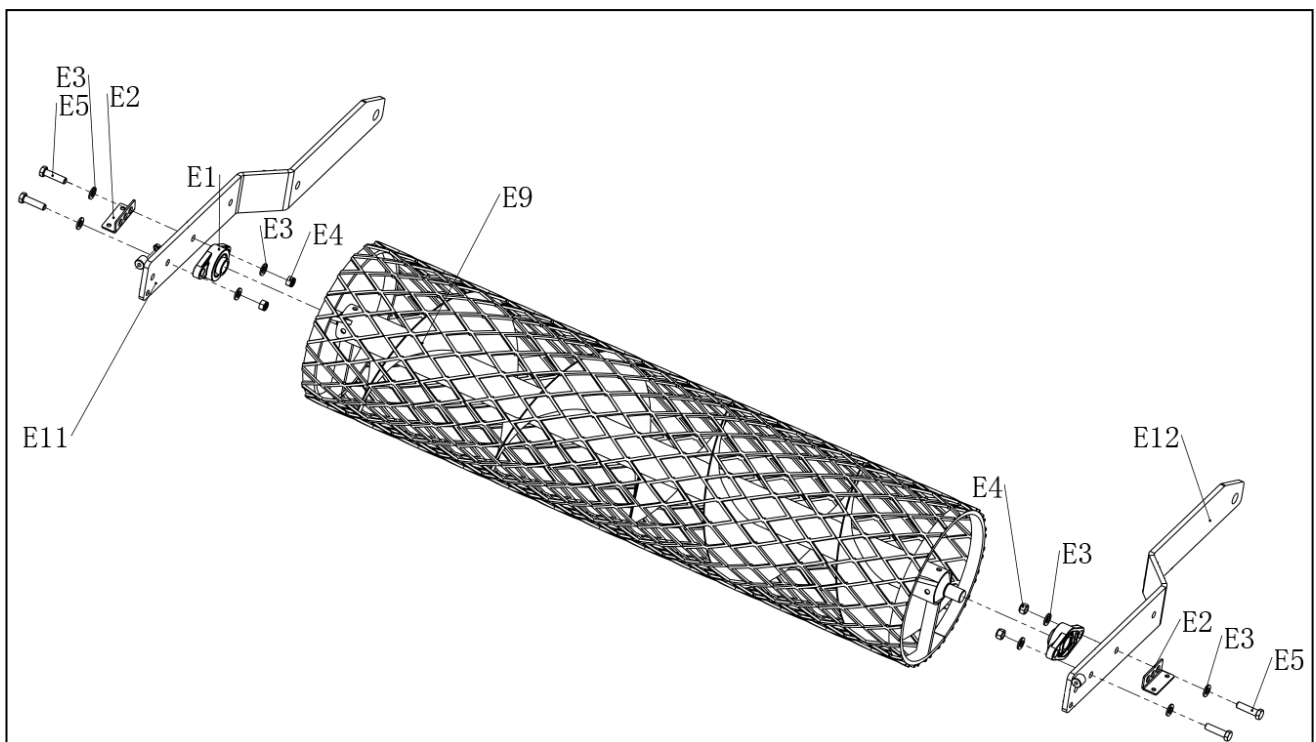

2. When the scraper welding parts installed (E10), it is necessary to place the welding parts of the left and right connecting arms (E11,E12)of the mesh wheel at the same height, then fasten them with bolts(E8), washer(E6), lock nut(E7), and then install the tension spring(E17) according to the below figure.

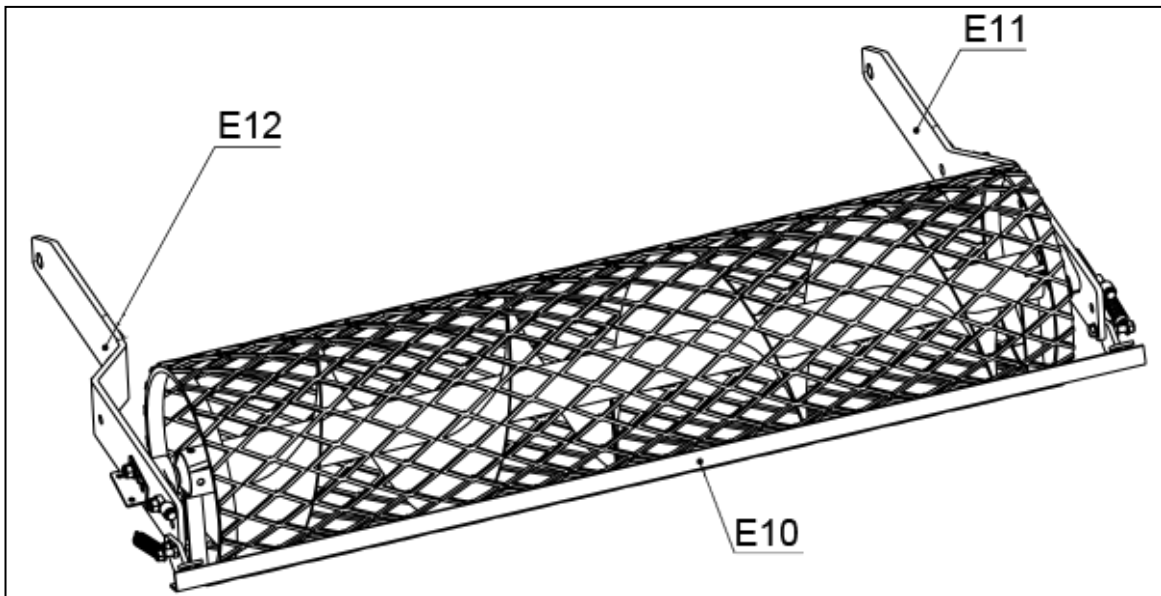
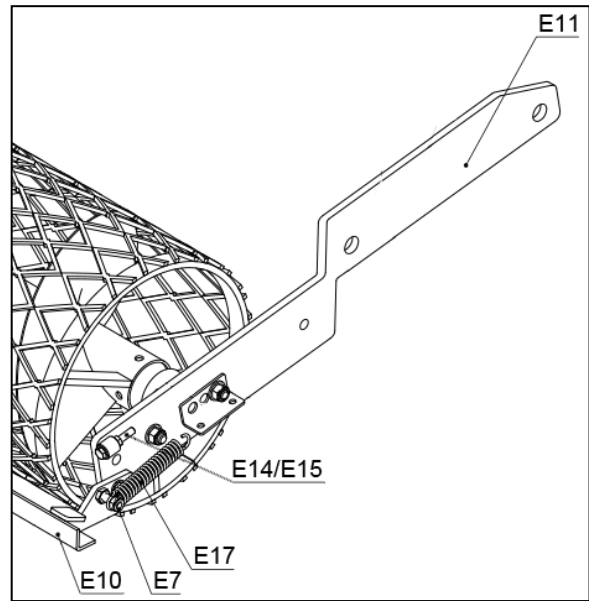
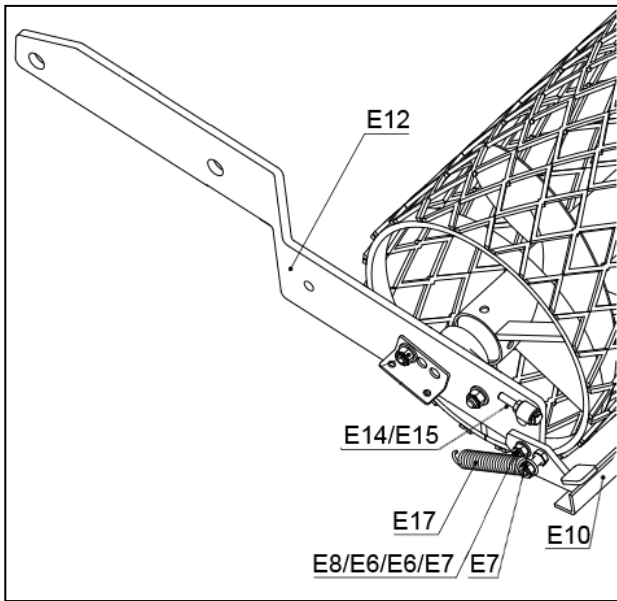

3. Install the adjusting rod(E16) according to the style shown in the figure right, and then fix it with the R pin (E13).

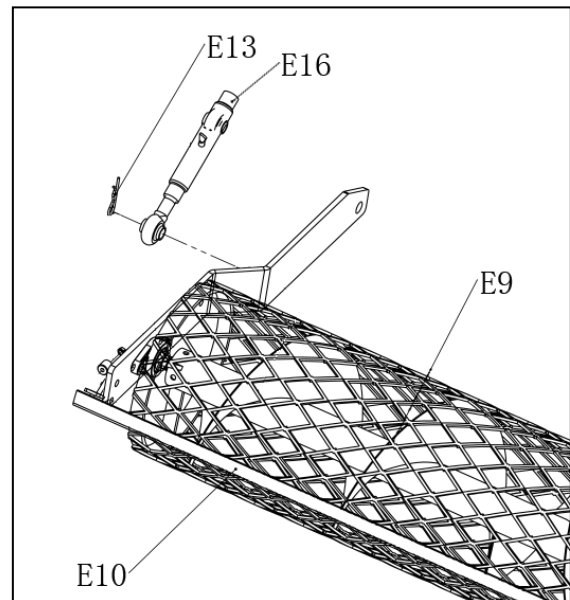

Importance: All bolts are locked in place without shaking.



WARNING: Once the assembly bolts are not fastened in place, there will be abnormal noises when the machine is working.

Parts no.	Description	Specifications	Qty
E1	Outer spherical ball bearing with seat		2
E2	Spring pull plate		2
E3	Flat washer	Ø12	8
E4	Lock nut	M12	4
E5	Hexagon Bolts	M12x45	4
E6	Flat washer	Ø10	4
E7	Lock nut	M10	4
E8	Hexagon Bolts	M10x35	2
E9	Welded parts of mesh wheel		1
E10	Scraper Welding Parts		1
E11	Welding parts of the right connecting arm of the mesh wheel		1
E12	Welding parts of left connecting arm of net wheel		1
E13	R pin		2
E14	Hexagon Bolts	M8x50	2
E15	Ordinary nut	M8	2
E16	Adjusting rod		2
E17	Tension spring		2

3. Install the roller assembly to the host

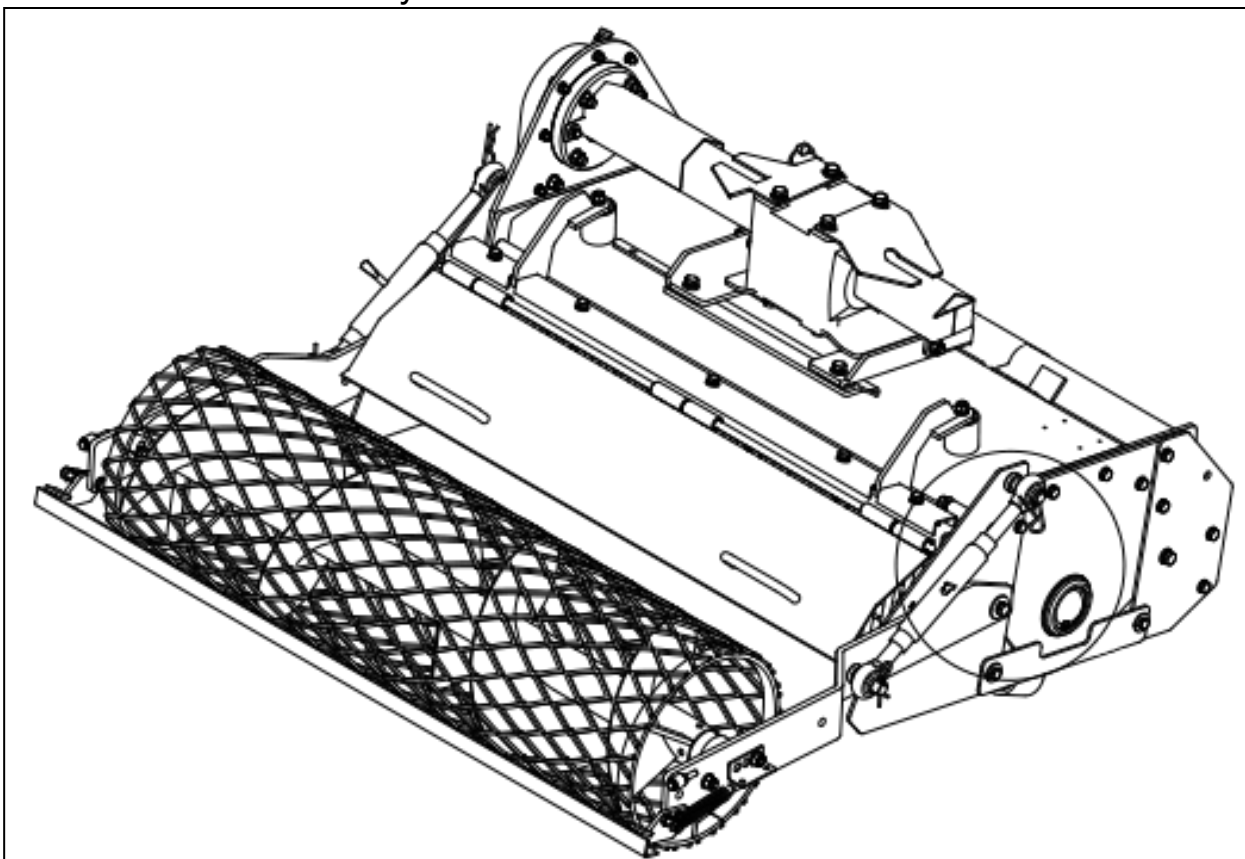

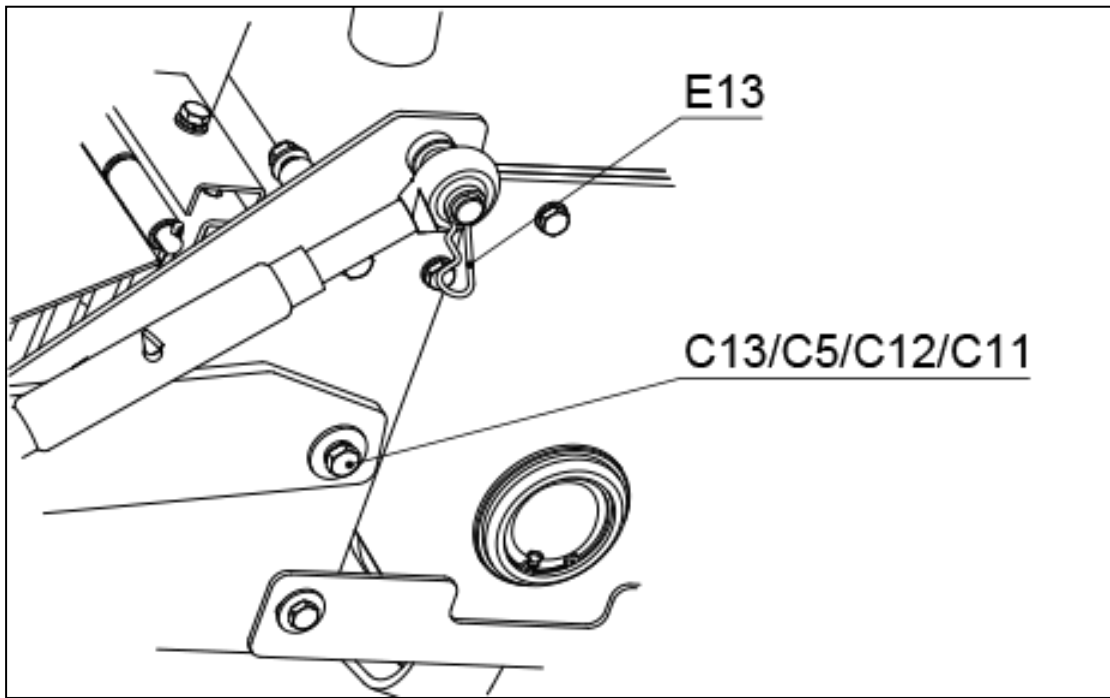

Installation steps:

1. Install the assembled roller assembly to the mounting hole on the host and fasten it with the bolts(C13).
2. After adjusting the length of the adjusting rod(E16) so that it can be installed on the hood, use the R pin(E13) to fix it on the host shaft.

Importance: All bolts are locked in place without shaking.



WARNING: Once the assembly bolts are not fastened in place, there will be abnormal noises when the machine is working.

Parts no.	Description	Specifications	Qty
C5	Spring washer	Ø12	2
C11	Spacer		2
C12	Large washer	Ø12	2
C13	Hexagon Bolts	M12x45	2
E13	R pin		2

4. Suspension and dust cover installation

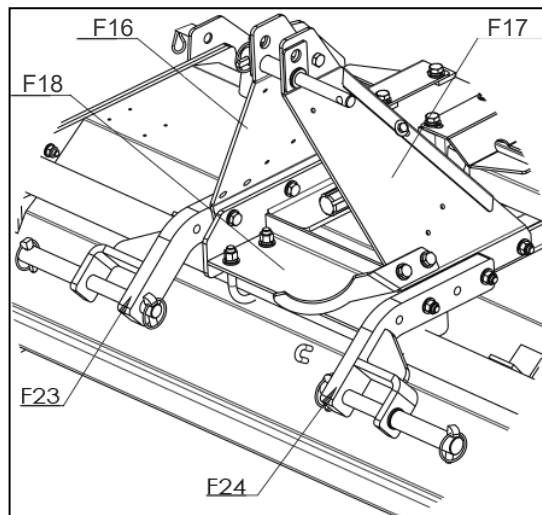
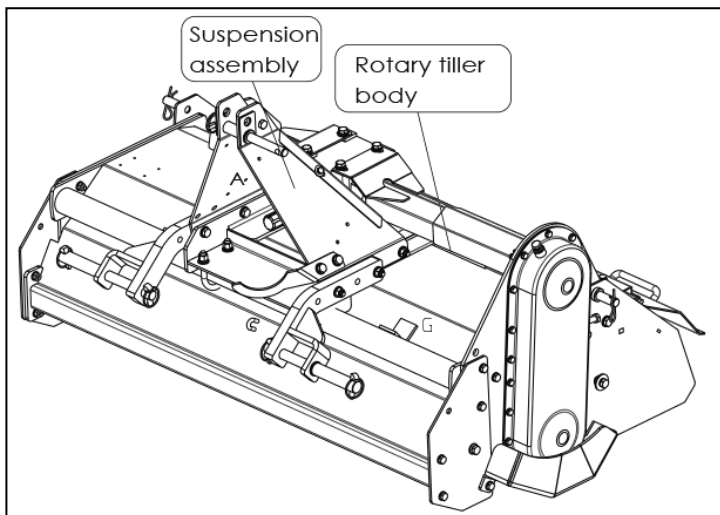

Installation steps:

1. Install the suspension components as shown in the figure

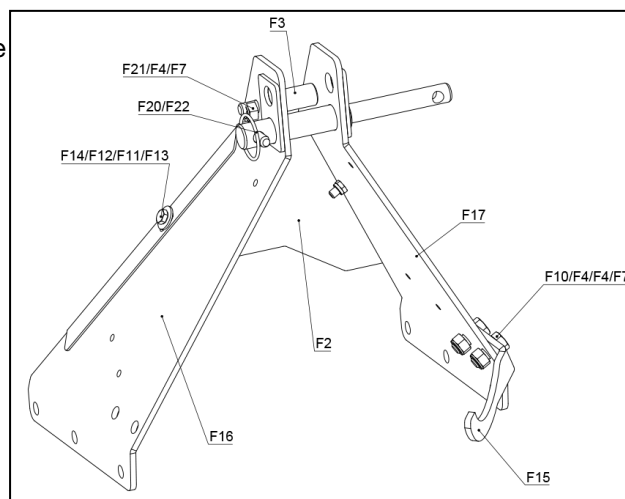

2. Hung the assembled components according to the hanging installation diagram on the hood, install the suspension components of bolt hole and the gearbox bracket(F18) on the hood welded parts installation hole alignment, then install the lower hitch-R(F23) and lower hitch-L(F24), install and tighten the bolts, flat washers and lock nuts in turn, and finally insert the lower hanging pin and lock pin (F25 and F20).

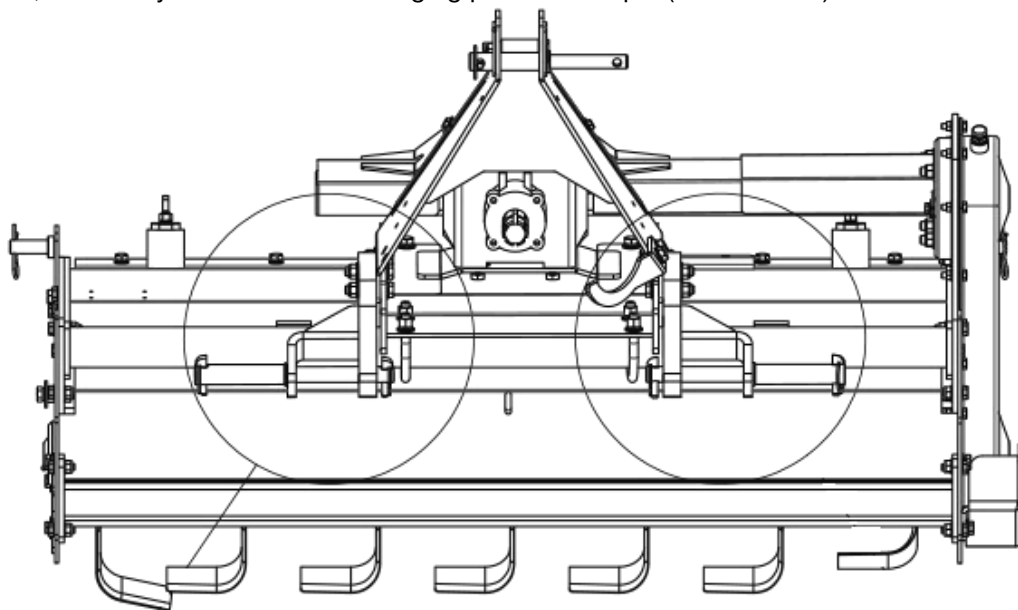

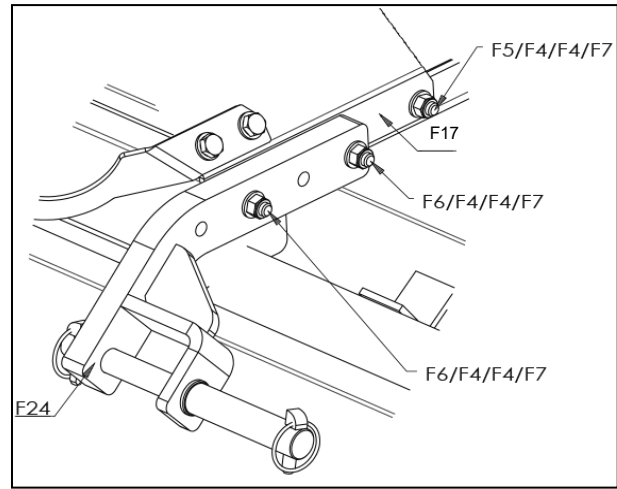
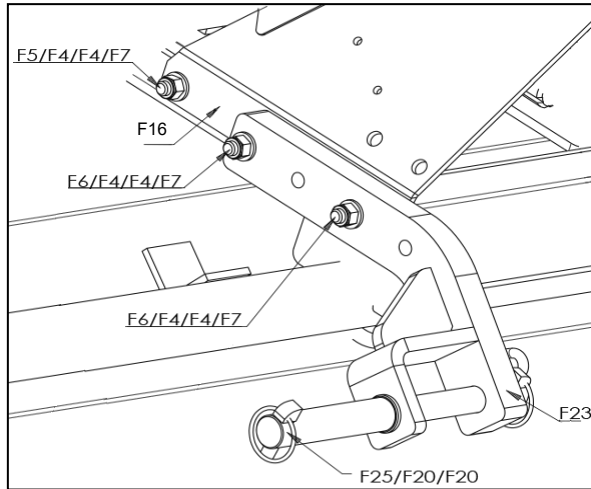

Note: Paying attention to the different bolt lengths of the hanging weldment and the hanging assembly under tightening extension (F6 and F5),

Note: Do not reverse the direction of the lower bracket assembly.

Importance: All bolts are locked in place without shaking.



WARNING: Once the assembly bolts are not fastened in place, there will be abnormal noises when the machine is working.

Parts no.	Description	Specifications	Qty
F2	Suspension rear connecting plate		1
F3	Upper hanging spacer		1
F4	Flat washer	Ø12	6
F5	Full-thread hexagon bolts	M12×35	2
F6	Full-thread hexagon bolts	M12×60	4
F7	Lock nut	M12	3
F10	Hexagon Bolts	M12x30	2
F11	Flat washer	Ø8	1
F12	Large washer	Ø8	2
F13	Lock nut	M8	2
F14	Hexagon Bolts	M8x25	2
F15	Drive shaft placement plate		1
F16	Right suspension plate weldment		1
F17	Left suspension plate weldment		1
F20	Lock pin		1
F21	Hexagon Bolts	M12x85	1
F22	Upper hanging pin		1
F23	Lower hitch-R		1
F24	Lower hitch-L		1
F25	Lower suspension pin		2

CONNECTING TRACTOR

1. Three-point linkage

⚠ Warning !

In the process of connection, when the tractor is moving, if there is people between the tractor and working machine, it may cause injury accident. Be sure no people stand between the tractor and working machine during the tractor moving.

Lower lifting pin types

TMG-TSB48

I and II

2. Connection and adjustment

⚠ Caution ! Make sure the tractor is fixed in the process of connection

- Start the tractor engine, tractor and machine head lower link under suspension corresponds to the position of the pin, rewind, stop, stop the engine, put up parking stalls.
- Connect Left towing arm, the left arm on the tractor towing the working machine is left hanging inserted pin, the locking detent. Right arm pulling the same way.
- Adjust the towing arms in the same height, as shown below:

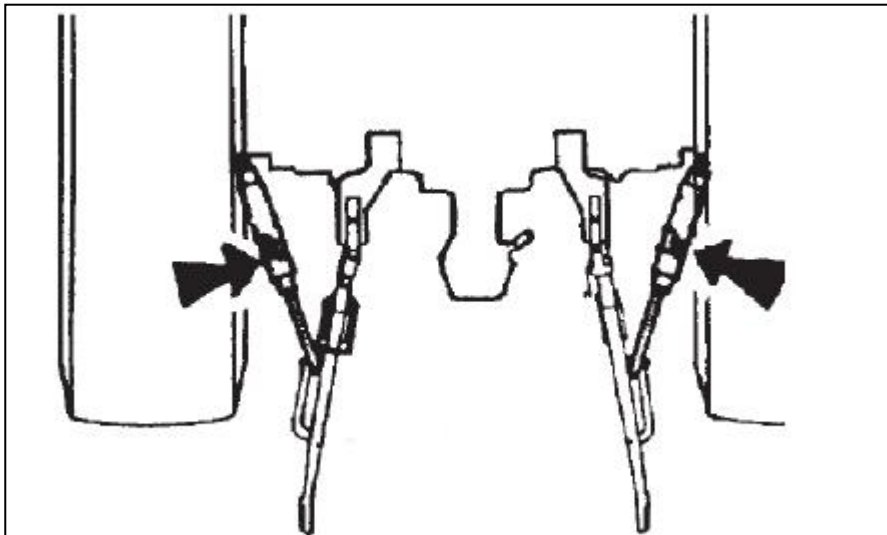

If the magnitude of the tractor towing arms is too narrow, adjust the left suspension pin inward as below:

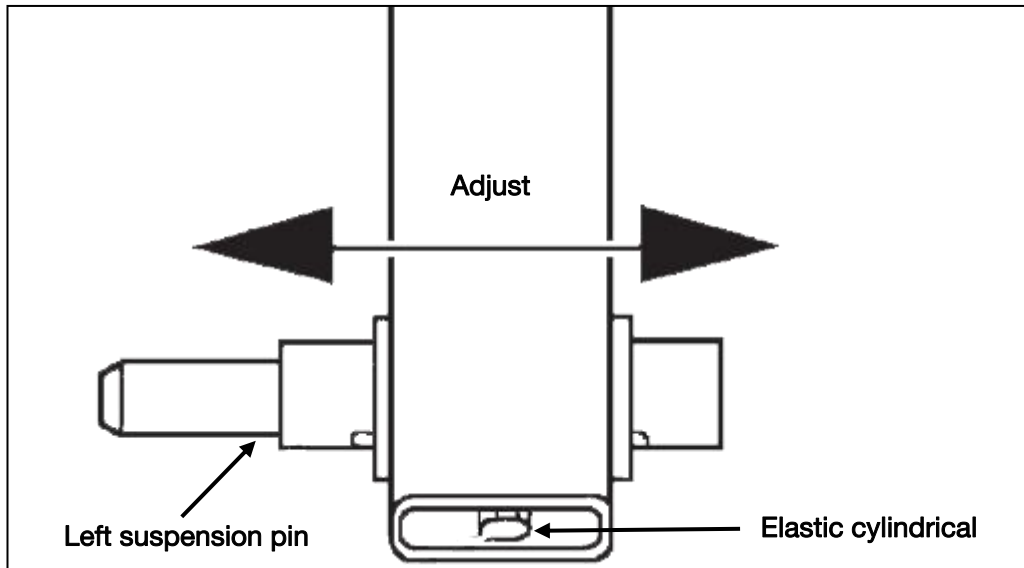

d. Adjust angle, to obtain the most appropriate cutting angle, adjust the upon 3-point linkage suspension to ensure the suitable cutting angle.

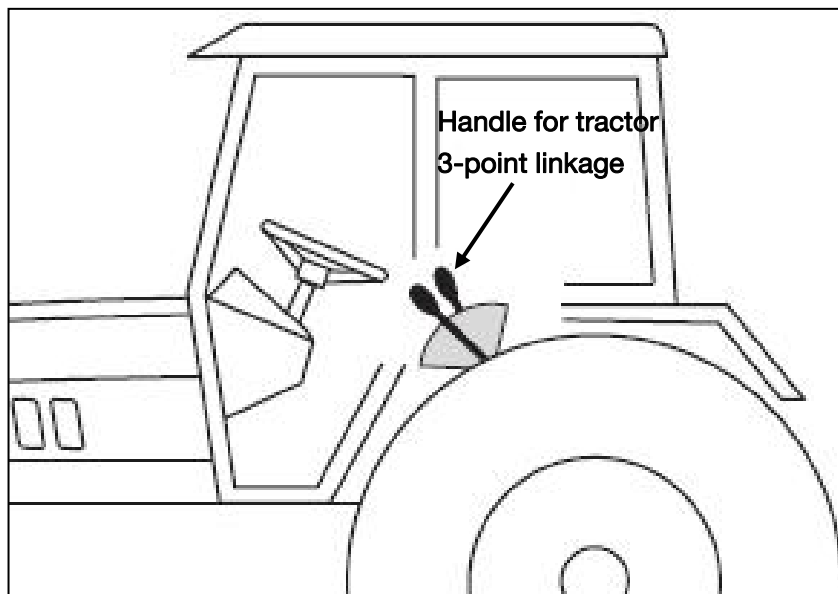
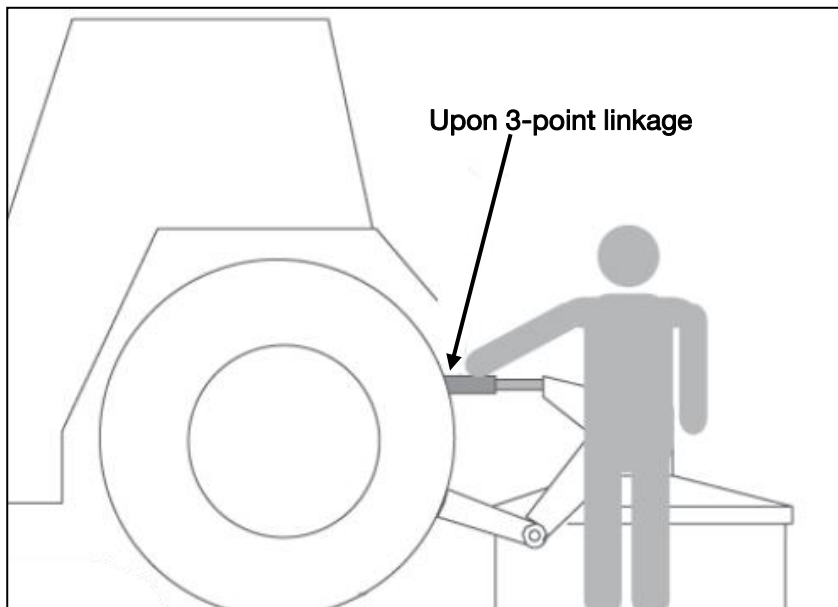

3. PTO installation

⚠ Danger

- If you use no plastic cover to protect the coupling, it is possible to be involved in the occurrence of injuries. Do not use no plastic casing coupling.
- If you use damaged couplings, injuries may occur entangled.
Couplings if damaged, replace it immediately. Please check if coupling have damage before using.
- When connected to the tractor and rotary hoe, as a third party do not pay attention, inadvertently let the power output shaft rotation, injuries may occur, after you cut off the power and stop the tractor engine PTO can be connected to the tractor.

a. Confirm coupling length

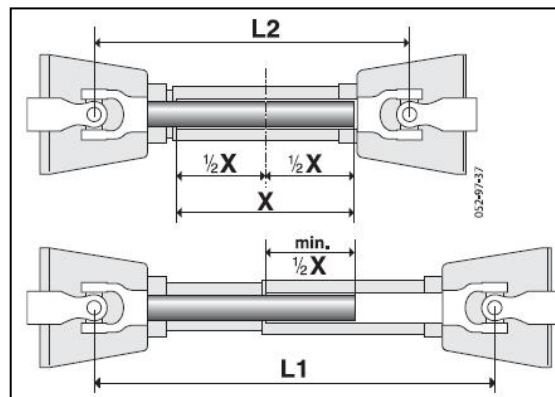

The minimum overlap of inner and outer coupling tube 1/2X size should be 220mm, if the size less than 100mm, please change the coupling

L1: The maximum length of connection to the tractor.

L2: The minimum length of the connection to the tractor

X: The overlap length.

b. The connection of coupling

1. Coupling connect to the rotary hoe end

Coupling with keyway end connect to the rotary hoe input shaft until the lock pin is exposed to in the original location.

2. Fixed coupling plastic cover

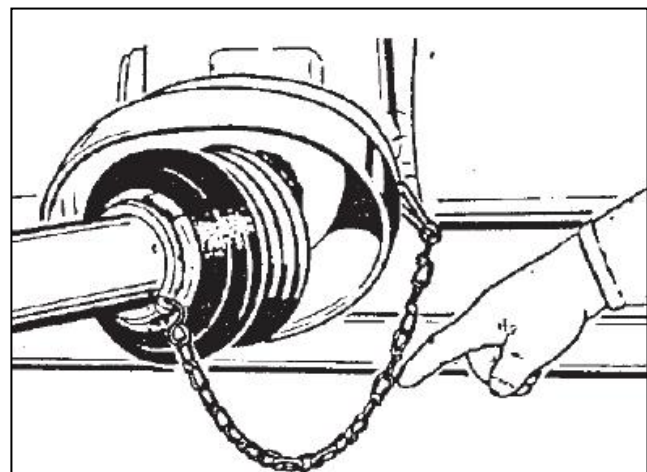

3. After connection, fixed the chain to prevent the plastic cover rotation
4. Max rotation angle of coupling

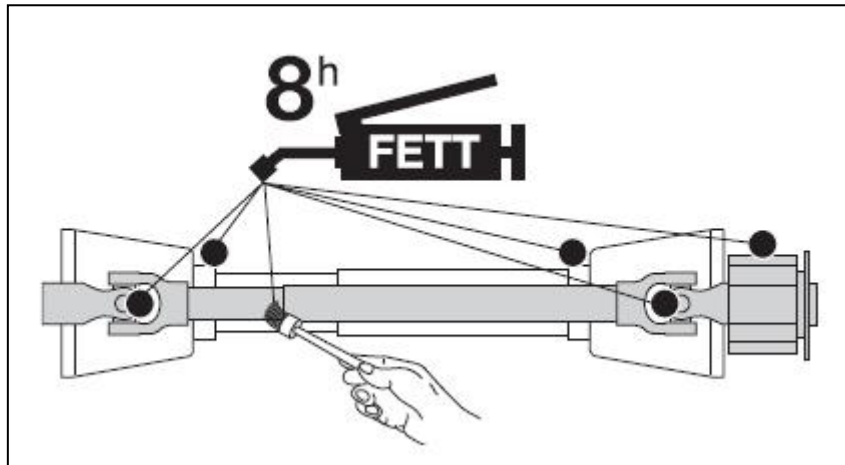

⚠ Noted !

If the shaft beyond its maximum operating angle of rotation at work, there will be unexpected injury accident. Be sure to fix the tractor three-point suspension before use.

4. Coupling lubrication and maintenance

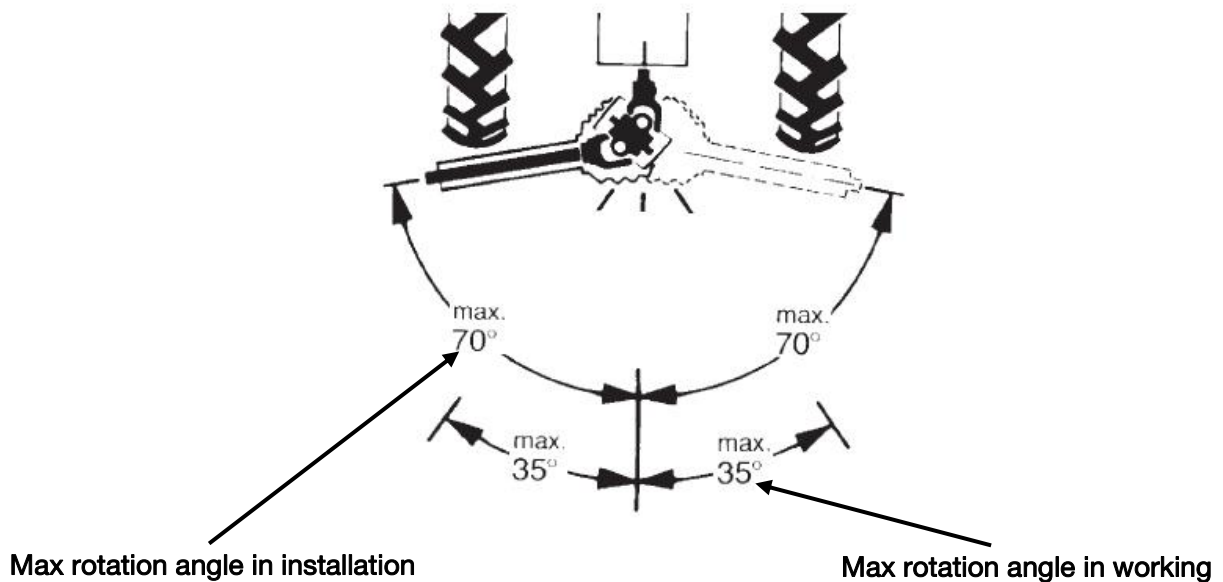

Proper grease lubrication and maintenance will greatly enhance the transmission efficiency of the tractor.

After eight hours of continuous operation coupling, check above the pointed position should be oiling and lubrication.

CHECK BEFORE OPERATING

1. Check before operating

1. Check the various parts of the tractor

Please check the parts according to the manual

2. Check the connection site

- (1) Fix connection pin of three-point suspension
- (2) Check the stand foot retract

3. Check the coupling

- (1) Whether the coupling ends effectively connected with the machine and tractor
- (2) Security chain is valid is fixed.
- (3) Plastic protective cover is complete.
- (4) Security chain sag length is appropriate.

4. Stone burier machine inspection

- (1) The cutter blade bolts are tightened.
- (2) Whether the gearbox rotation is normal, the hydraulic oil in gearbox not exceed the volume of 1/3, if less need to add gear oil.
- (3) The various parts of the bolts and nuts are tightened.
- (4) The oil in each parts should be adequ

2. Check during engine starting

Danger

- If start the engine when the PTO does not cut off the power ,it may cause harm to the people around. Always switch off the PTO and then start the engine.
- When starting the engine, if it does not lower the rotary tiller is approaching, has no intention of falling or rising, people around may cause injury. Keep machine is approaching low before starting the engine.

1. Check the drive system

The new machine or machine long unused, you must first idling operation.

- (1) Start the tractor engine and low speed transfer to PTO.
- (2) The engine speed was adjusted to 1000 rev / min mode, idling about 5 minutes.
- (3) if the above normal, the rotational speed was adjusted to 500-540 rev / min mode, idle for about 5 minutes.

If the drive system has a problem, you can refer tractor manual investigation.

2. Check the tractor hydraulic system

Operate tractor three-point suspension lift handle and hydraulic output handle, lifting and turning the machine to ensure no problems.

If you have questions, please contact the tractor dealer.

LUBRICATION POINTS SUMMARY

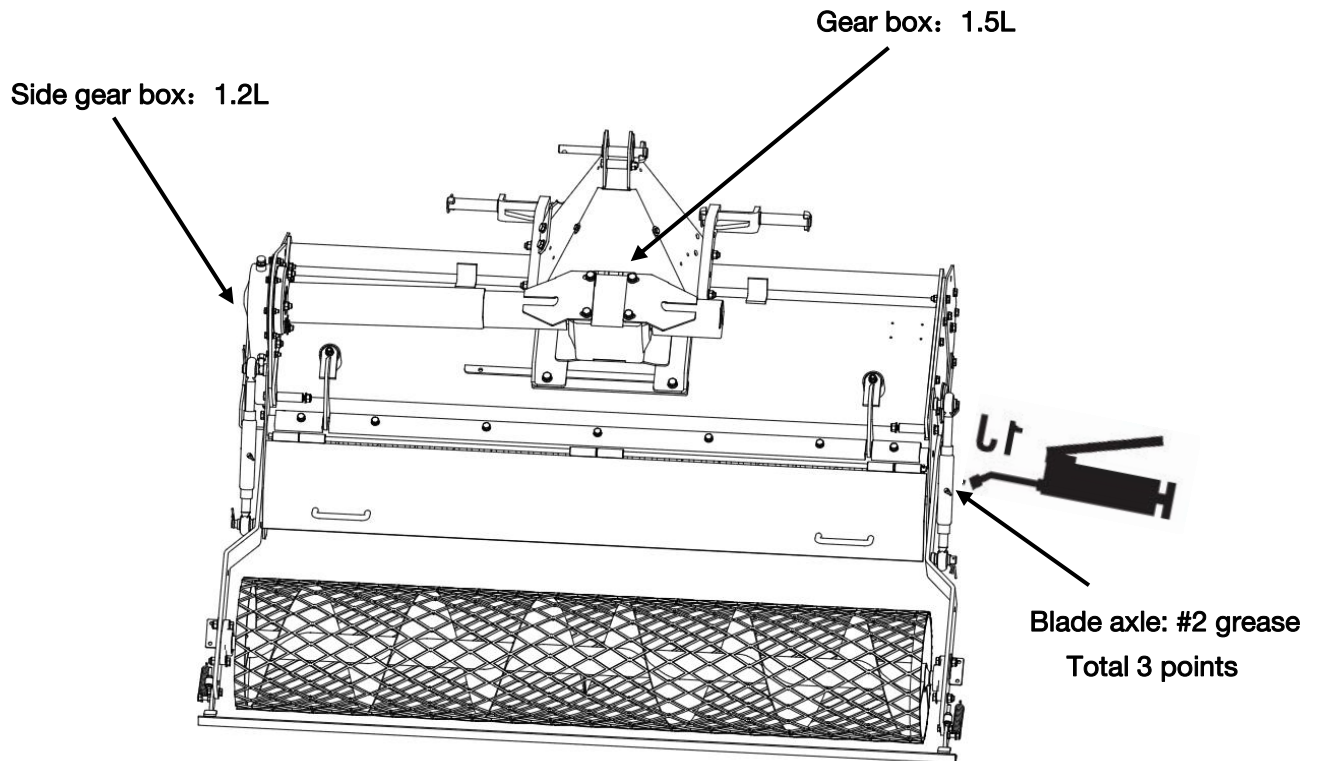

- Fuel and smear with clean oil
- Release the original gearbox oil when refueling.
- Designated parts have been oiling, please confirm before use.

⚠ Noted !

Change the oil in gearbox after the new hoe put in use after 50 hours

Make routine inspection per 50 hours

Gear oil and grease oil information

Lubrication points	Oil #	Change time
Gearbox	SAE90 GL-5	300 hours/season
Blade axle nozzle	2# grease	Before use

OPERATING ESSENTIALS

⚠ Danger

- Don't touch blade when in operation, injuries may occur.
- In high-speed rotating operation, the stone will fly out, take close attention to yourself and the problem around.

⚠ Warning

- Exceed the PTO speed may cause injury accident, make sure to operate within the specified speed.
- Keep low-speed operation in tilt ground.

Note the front and surroundings while driving,

1. Attentions during in use

1. When start job, lift the rotary tiller, make sure accelerate the blade axle to the rated speed, and then drop the tiller until the blade buried to the desired depth. Do not accelerate the shaft or drop the tiller after buried the blade, to avoid overloading the tractor or damaging the blades.
2. Within the job, should try to drive slowly, so that can guarantee the work quality, crushing clouds and reduce mechanical wear and tear, pay attention to whether there is any noise or metal percussion sounds, and observe the pulverizes, deep tillage situations, if there is any exception should immediately stop work and check, after the exclusion can continue operations.
3. Stop work when turn a corner, raise the tiller until the blade off the ground, and reduce tractor throttle to avoid damage to the blade. When raise rotary tiller, make sure the universal -joint tile angle less than 30 degrees, it may cause noise if over the degrees and then premature wear or damage
4. When drive in reverse, crossing the ridge and transfer to other land, should raise the tiller to the highest position, and cut off the power to avoid any damages, if more to far away , make sure to use lock device fix the machine well.
5. After working, should maintenance the machine, remove dirt and debris, check the connection fastening case, each point lubricant filling oil, to prevent aggravating wear.

2. Stone burier adjustment

1. Side adjustment, park the tractor with rotary hoe in flat ground, drop the rotary hoe until the blade 5cm from the ground, check the the tip for sides blades have the same distance to ground, in order to ensure the blade axle in straight level, tillage depth evenly.
2. Front and rear adjustment. When drop the rotary tiller to the required depth, observe universal joint angle and the rotary tiller angle is in a near horizontal position. If the angle is too large, adjust the rod, so that rotary hoe in the horizontal position.
3. Lifting height adjustment. Rotary job, angle does not allow more than 10 degrees, When drive in reverse, the angles are not allowed more than 30 degrees. Pay special attention when lifting. For increased again rotary tiller, the universal joint power should be removed.

OPERATING FINISH

1. Seiri and check after operating

- (1) Should organize and clean the rotary machine after the operation of rotary machines, remove the grass clippings, dirt during the job.
- (2) After using a rotary tiller should be careful to check some of the parts can be damaged, if parts need to be replaced, should also pay attention to cut off all the power, turn off the tractor firstly.
- (3) For the most easily damaged parts must be carefully checked immediately so as not to affect the next use. Particular pay attention to the blades, generally three methods of replacement: outward, inward turn, a mixed installation, to respond to different working environment, pay attention to distinguish; adjust blades and note blade axle speed

2. Separate from the tractor

- (1) The PTO drive shaft ends will be removed from the tractor and rotary tiller end.
- (2) Set flat rotary tiller, separate the tractor suspension with 3-point hitch from rotary tiller.

3. Storage

When machine will be placed for a long time, make sure to inspect parts , add oil , and make dust-proof work.

MAINTENANCE SCHEDULE

Inspection unit list	Inspection time
Blade	Before/in/post the job
Cutter	Before/Post the job
Greasing	59 hours/times
Bolts or nuts loose	1 hour in the new use
Gear oil	50hours in the new use, and per 300hours or seasonal conduct after changing oil

TROUBLESHOOTING

PROBLEM	PROBABLE CAUSE	SOLUTION
Abnormal sound or abnormal	<ol style="list-style-type: none"> 1. Loose blade bolt 2. Loose cutter bolts 3. Incorrect oil 4. Gear, bearing damage 5. Overload or soil hardness is high 	Tighten the bolts Change Oil Replace damaged Parts Readjust tillage depth
uneven soil after tilling and sowing	Adjusting plate position was not coordinated well	Coordinate well the adjusting plate position
Blade axle not work or rotate slowly	<ol style="list-style-type: none"> 1. Parts installation errors 2.Excessive debris wrapped on the blade axle 	Check the blade axle installation Clear debris
Curved blade	1.Not replace the deformed blade	Replace the blades in time
Coupling abnormal sound	<ol style="list-style-type: none"> 1. No Oil 2. Overload angle is too large 	Add lubrication Proper use according to Manual

EXPLODED VIEW & PARTS LIST

1. Main-frame assembly

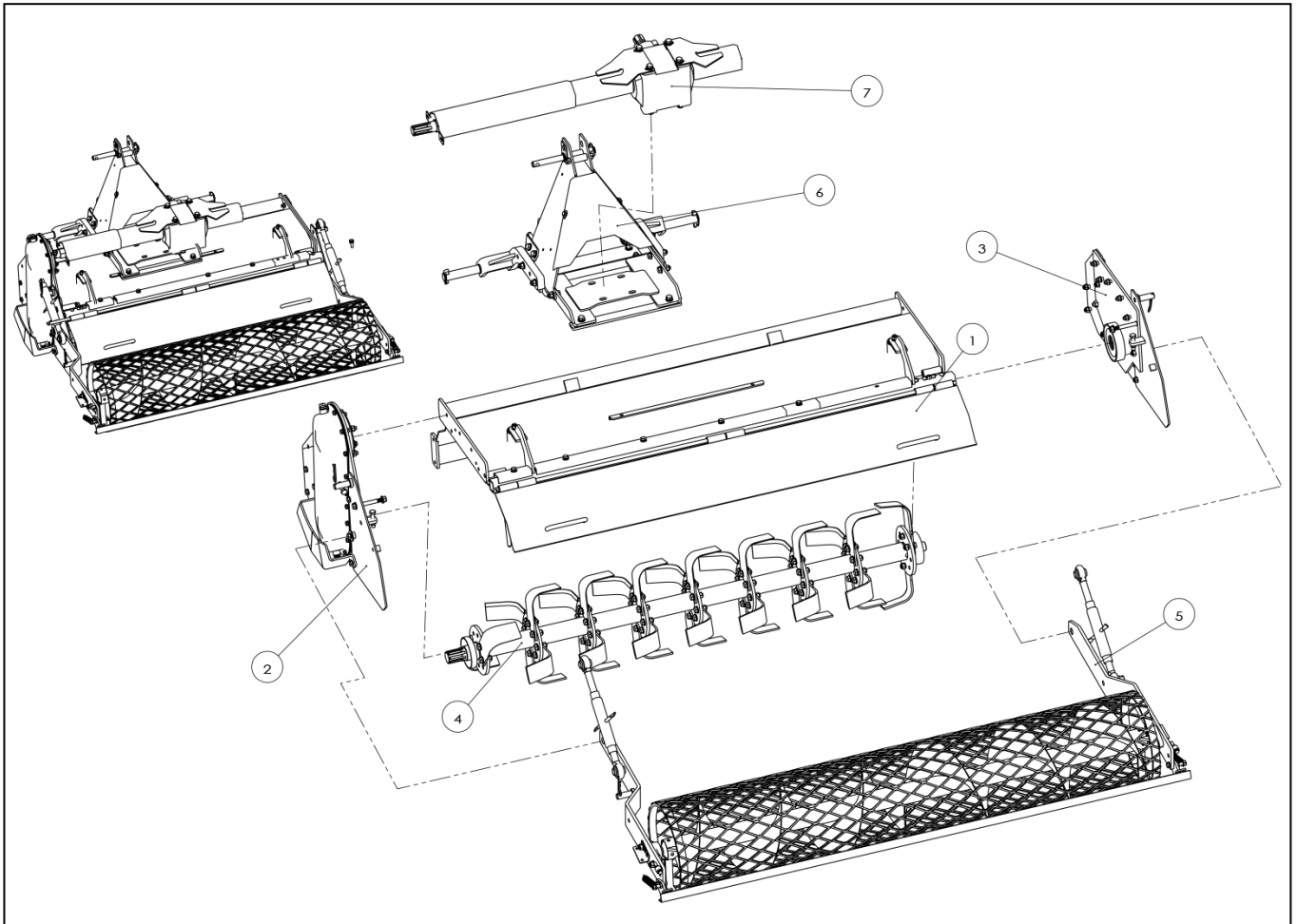

PARTS LIST

Ref.No.	Description	Qty	Ref.No.	Description	Qty
1	Hood assembly	1	5	Roller assembly	1
2	Slide drive assembly	1	6	Suspension assembly	1
3	End cover assembly	1	7	Gearbox mounting assembly	1
4	Blade axle assembly	1			

2. Hood assembly

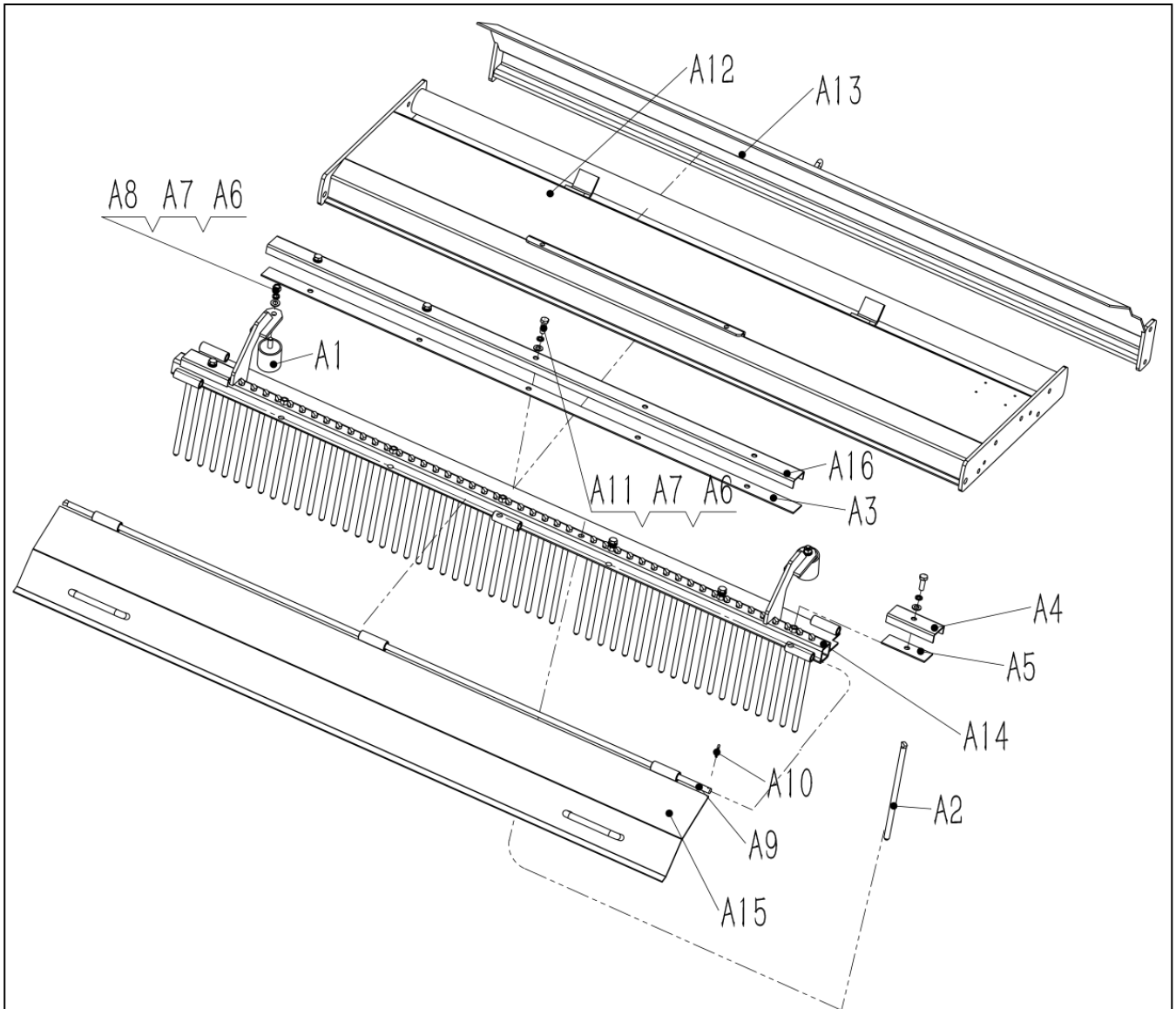

PARTS LIST

Ref.No.	Description	Qty	Ref.No.	Description	Qty
A1	Shock-absorbing block	2	A9	Rear baffle shaft	1
A2	Flat teeth	39	A10	Split pin 4x20	1
A3	The rubber pad (I)	1	A11	Full-thread hexagon bolts M10x30	5
A4	Flat teeth pressing plate (II)	2	A12	Hood panel	1
A5	The rubber pad	2	A13	Front baffle plate	1
A6	Plain washer Ø10	7	A14	Flat teeth bracket	1
A7	Spring washer Ø10	7	A15	Rear baffle plate	1
A8	Hexagon nuts M10	2	A16	Flat teeth pressing plate (1)	1

3. Slide drive assembly

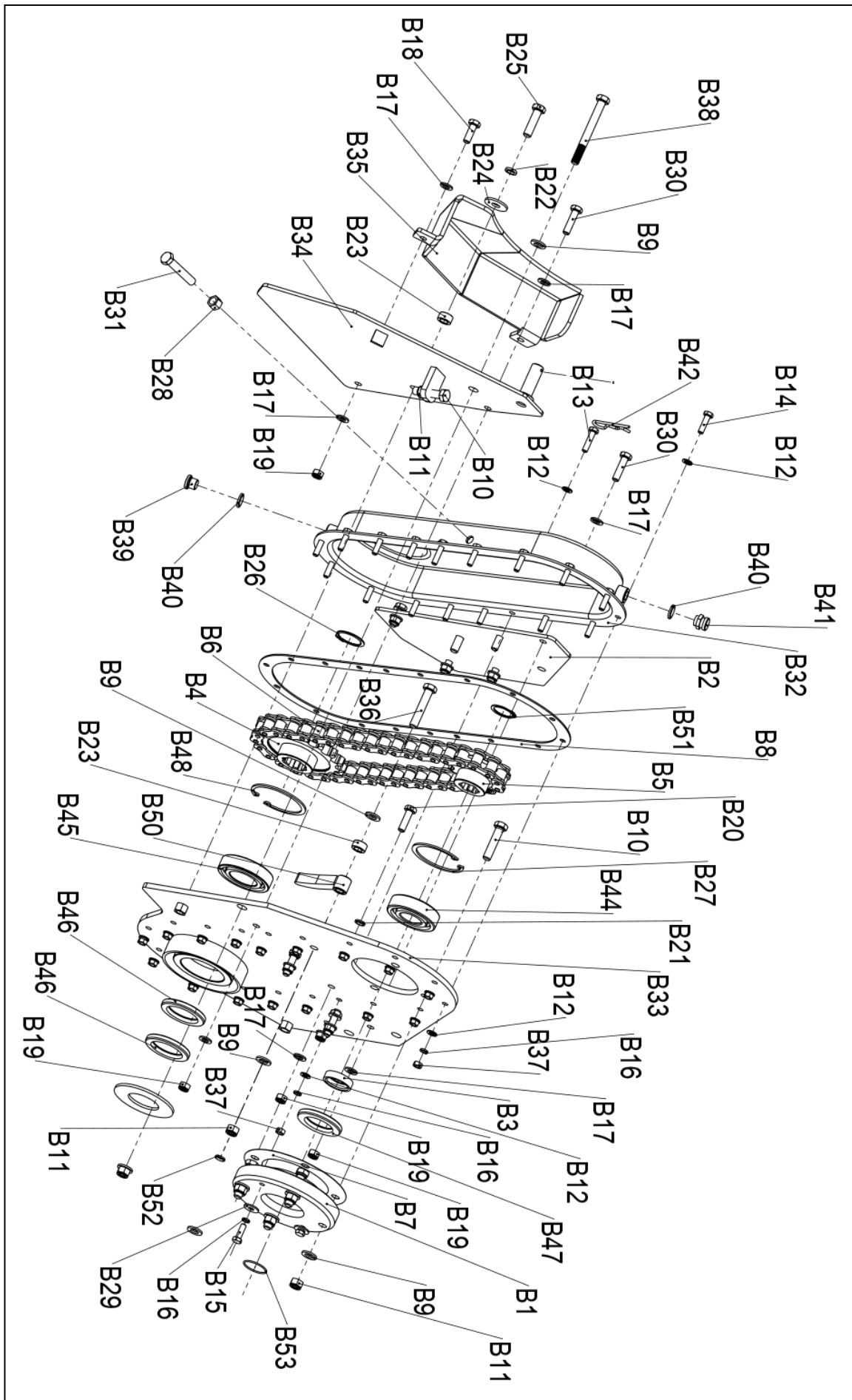

PARTS LIST

Ref.No	Description	Qty	Ref.No	Description	Qty
B1	Drive shaft bearing seat	1	B28	Hexagon nuts M12	1
B2	Front connecting plate	1	B29	Large plain washer Ø8	2
B3	Oil seal sleeve	1	B30	Full-thread hexagon bolts M10×40	2
B4	Large chain wheel	1	B31	Full-thread hexagon bolts M12×70	1
B5	Small chain wheel	1	B32	Chain case	1
B6	Roller chain 1×42	1	B33	Right side plate of blade axle	1
B7	Fiber seal	1	B34	Rear connecting bracket- R	1
B8	Cork mat	1	B35	Chain case guard	1
B9	Plain washer Ø12	9	B36	Full-thread hexagon bolts M12×65	1
B10	Full-thread hexagon bolts M12×55	5	B37	Hexagon nuts M8	18
B11	Locknut M12	7	B38	Hexagon head bolts M12×110	1
B12	Plain washer Ø8	36	B39	Inner hexagonal plug M16×1.5×15	1
B13	Full-thread hexagon bolts M8×35	2	B40	Combined sealing gaskets 16.4×22×2.5	2
B14	Full-thread hexagon bolts M8×30	16	B41	Grease nipple M16×1.5	1
B15	Full-thread hexagon bolts M8×25	2	B42	R Pin Ø4	1
B16	Spring washer Ø8	20	B43	Full-thread hexagon bolts M12×35	1
B17	Plain washer Ø10	18	B44	Deep groove ball bearing 6307	1
B18	Full-thread hexagon bolts M10×30	5	B45	Deep groove ball bearing 6209	1
B19	Locknut M10	10	B46	shaft seal 50×72×8	2
B20	Full-thread hexagon bolts M10×35	3	B47	shaft seal 45×72×8	1
B21	Combined sealing gaskets 10.4×16×2	2	B48	Retaining rings for bor P 85	1
B22	Spring washer Ø12	2	B49	Sealing felt ring	1
B23	Sleeve	2	B50	Tensioner plate	1
B24	Large plain washer Ø12	1	B51	Retaining rings for shaft 34	1
B25	Full-thread hexagon bolts M12×45	1	B52	Combined sealing gaskets 12.4×16×2	5
B26	Retaining rings for shaft 42	1	B53	O-Ring 34×2	1
B27	Retaining rings for borP 80	1			

4. End cover assembly

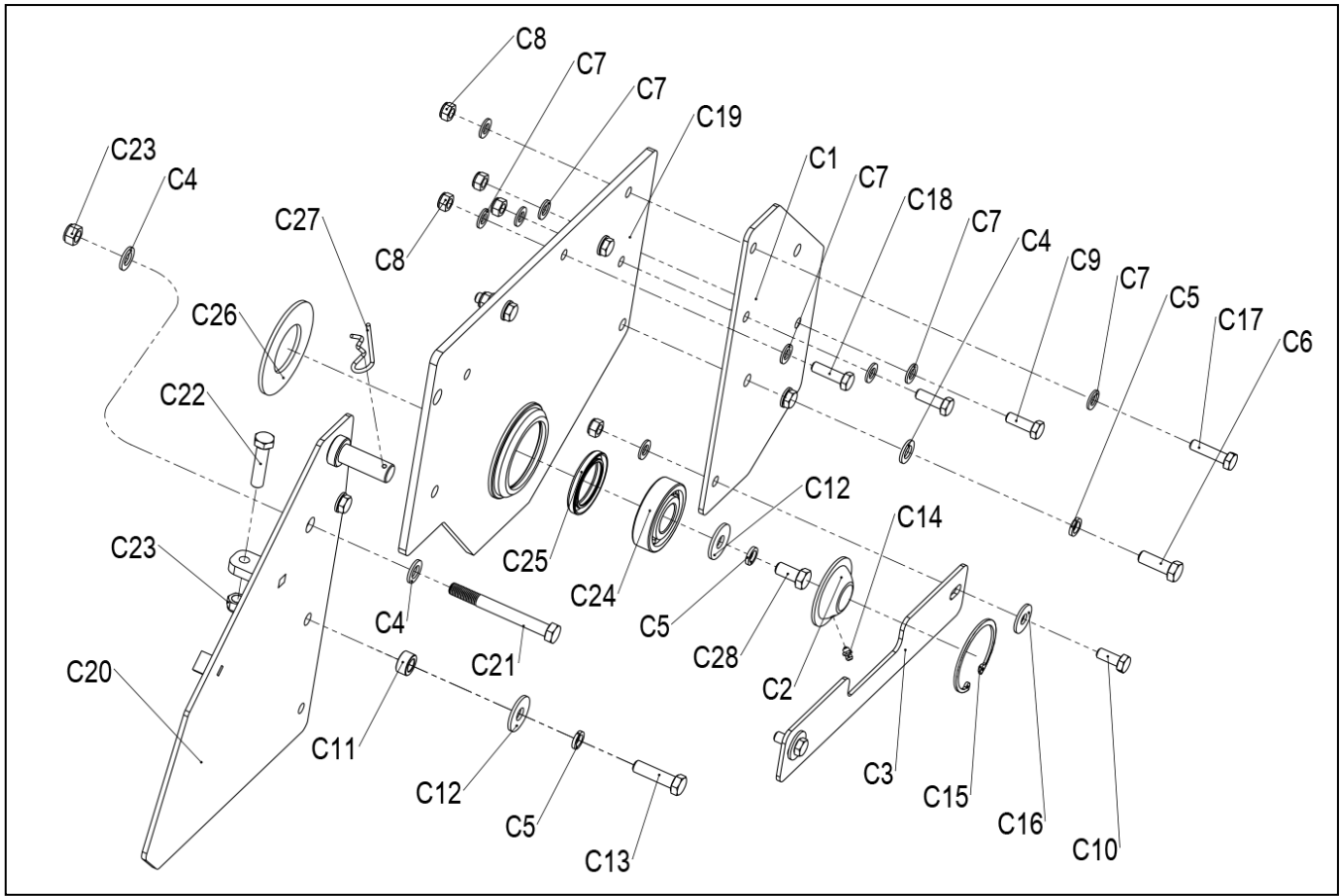

PARTS LIST

Ref.No	Description	Qty	Ref.No	Description	Qty
C1	Front connecting plate	1	C15	Retaining rings for bor P72	1
C2	End cap	1	C16	Large plain washer Ø10	2
C3	Lower support plate	1	C17	Full-thread hexagon bolts M10×40	2
C4	Plain washer Ø12	3	C18	Full-thread hexagon bolts M10×35	3
C5	Spring washer Ø12	3	C19	Side plate-L	1
C6	Full-thread hexagon bolts M12×35	1	C20	Rear connecting bracket- L	1
C7	Plain washer Ø10	18	C21	Hexagon head bolts M12×110	1
C8	Locknut M10	10	C22	Full-thread hexagon bolts M12×50	1
C9	Full-thread hexagon bolts M10×30	3	C23	Locknut M12	2
C10	Full-thread hexagon bolts M10×25	2	C24	Deep groove ball bearing 6306	1
C11	Sleeve	1	C25	shaft seal 45×65×8	1
C12	Large plain washer Ø12	2	C26	Sealing felt ring	1
C13	Full-thread hexagon bolts M12×45	1	C27	R Pin Ø4	1
C14	Grease nipple M6	1	C28	Full-thread hexagon bolts M12×25	1

5. Blade axle assembly

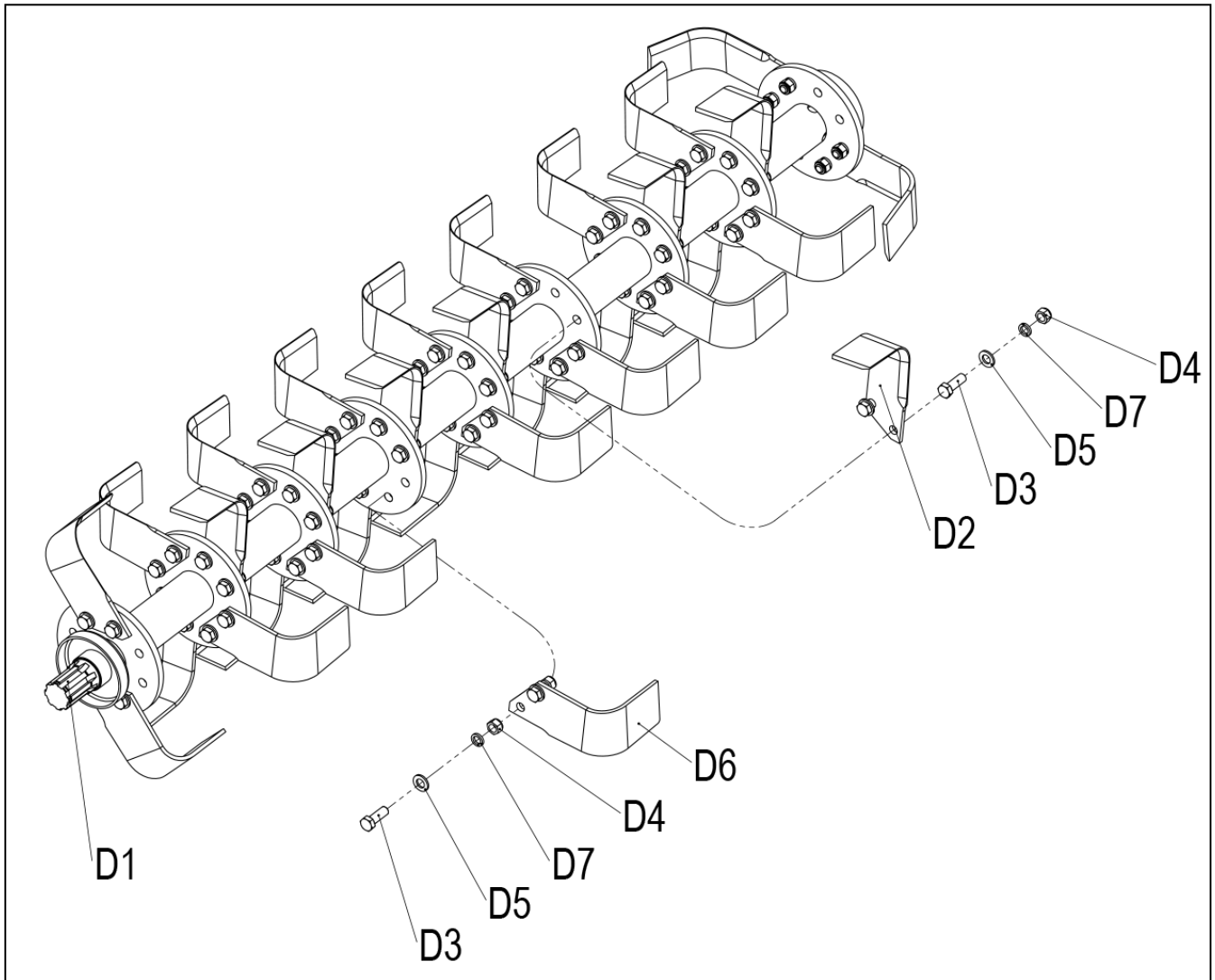

PARTS LIST

Ref.No	Description	Qty	Ref.No	Description	Qty
D1	Blade axle	1	D5	Plain washer Ø12	64
D2	Blade-R	16	D6	Blade-L	16
D3	Full-thread hexagon bolts M12×35	64	D7	Spring washer Ø12	64
D4	Locknut M12	64			

6. Roller assembly

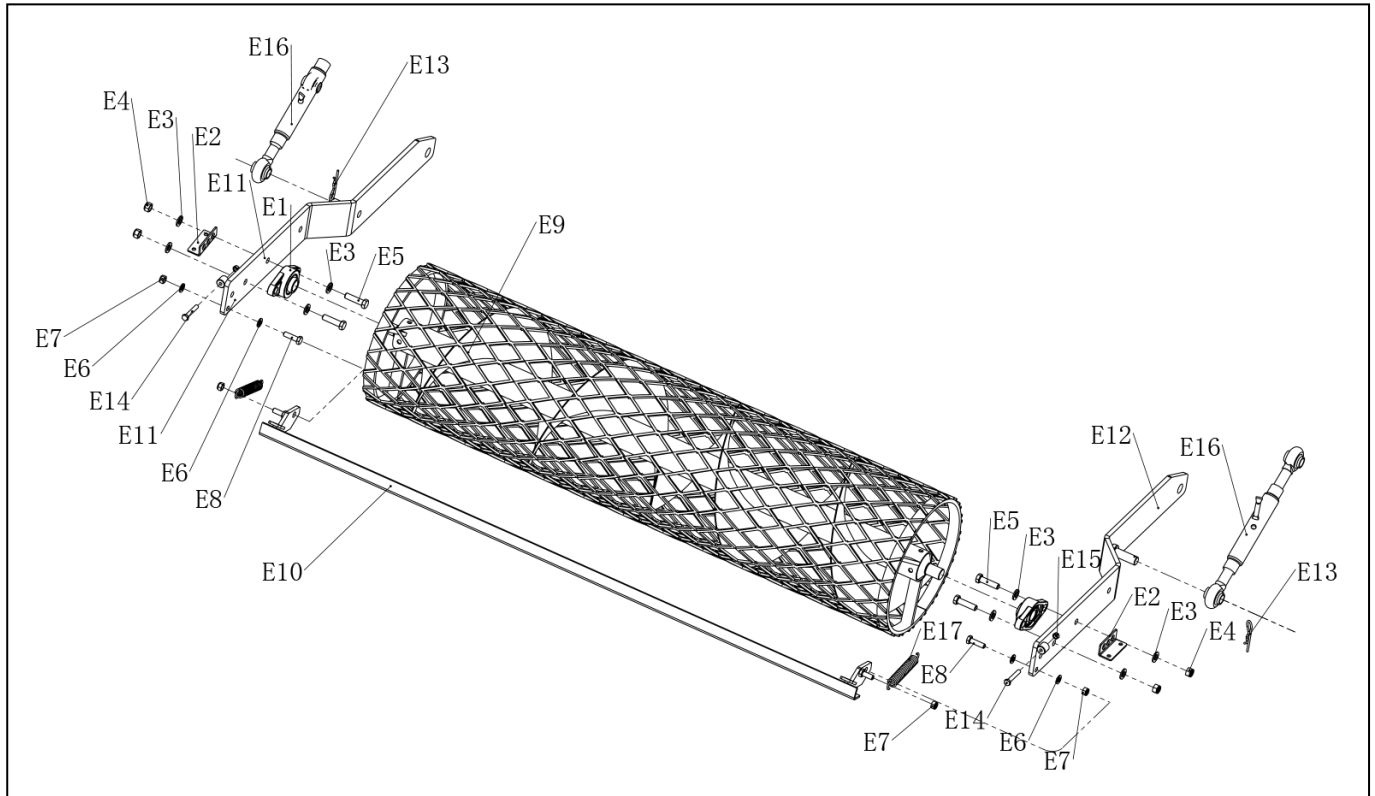

PARTS LIST

Ref.No	Description	Qty	Ref.No	Description	Qty
E1	Outer spherical ball bearing with seat	2	E10	Mud shield	1
E2	Spring pull plate	2	E11	Connecting arm-L	1
E3	Plain washer Ø12	8	E12	Connecting arm-R	1
E4	Locknut M12	4	E13	R Pin Ø4	2
E5	Full-thread hexagon bolts M12×45	4	E14	Full-thread hexagon bolts M8×50	2
E6	Plain washer Ø10	4	E15	Hexagon nuts M8	2
E7	Locknut M10	4	E16	Adjusting rod	2
E8	Full-thread hexagon bolts M10×35	2	E17	Tension spring	2
E9	Net wheel	1			

7. Suspension assembly

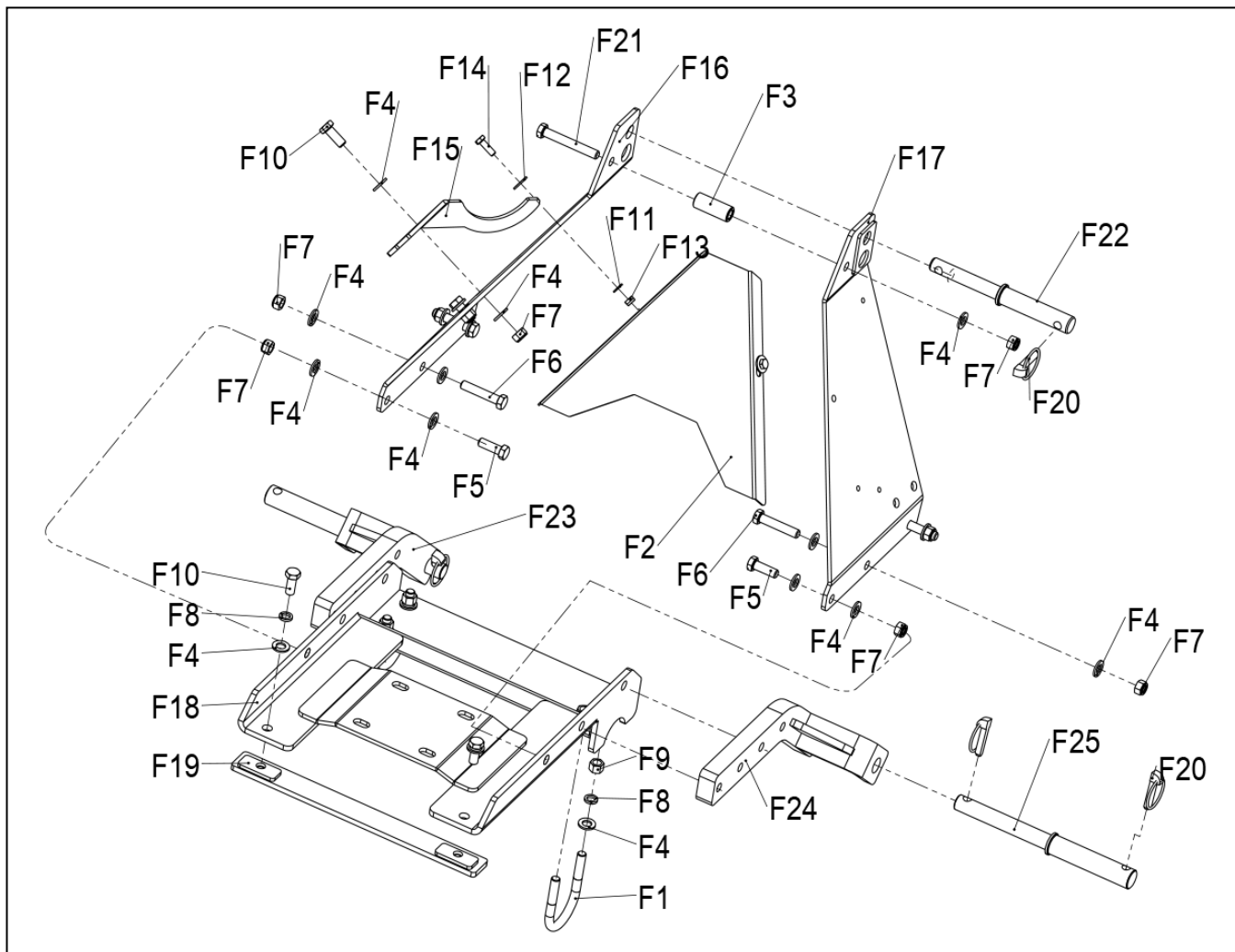

PARTS LIST

Ref.No	Description	Qty	Ref.No	Description	Qty
F1	U-bolt	2	F14	Full-thread hexagon bolts M8x25	2
F2	Rear connecting plate	1	F15	PTO Retaining plate	1
F3	Upper suspension spacer	1	F16	Left suspension plate	1
F4	Plain washer Ø12	23	F17	Right suspension plate	1
F5	Full-thread hexagon bolts M12x35	2	F18	Gearbox bracket	1
F6	Full-thread hexagon bolts M12x60	4	F19	Clamp plate	1
F7	Locknut M12	9	F20	Pin 12	5
F8	Spring washer Ø12	6	F21	Hexagon head bolts M12x85	1
F9	Hexagon nuts M12	4	F22	Pin	1
F10	Full-thread hexagon bolts M12x30	4	F23	Lower hitch-R	1
F11	Plain washer Ø8	2	F24	Lower hitch-L	1
F12	Large plain washer Ø8	2	F25	Lower suspension pin	2
F13	Locknut M8	2			

8. Gearbox mounting assembly

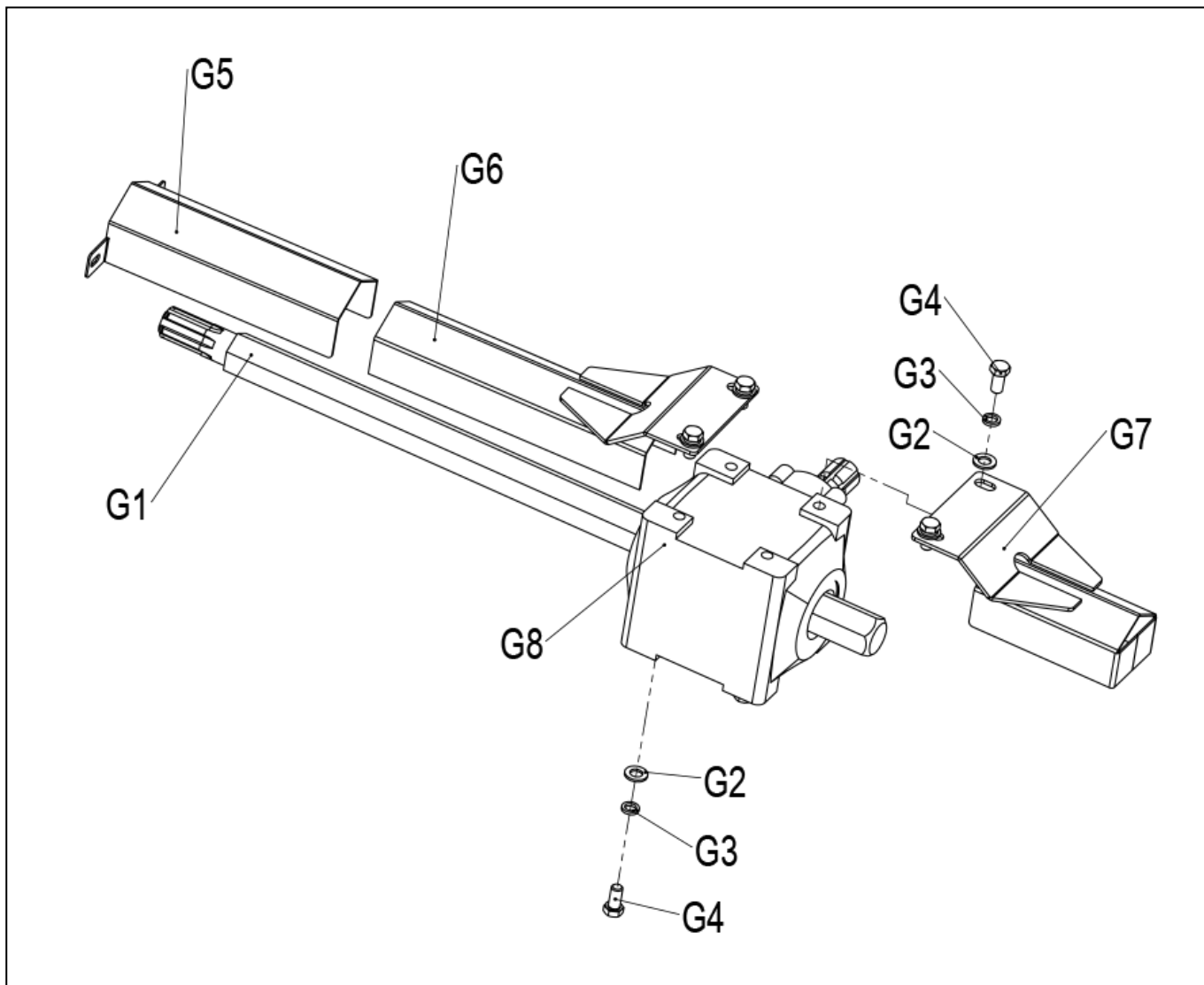

PARTS LIST

Ref.No	Description	Qty	Ref.No	Description	Qty
G1	Transmission shaft	1	G5	The protective shield (I)	1
G2	Plain washer Ø12	8	G6	The protective shield (II)	1
G3	Spring washer Ø12	8	G7	The protective shield (III)	1
G4	Full-thread hexagon bolts M12×25	8	G8	Gear box	1